

IWAKI

Electromagnetic Metering Pump

EH-Y-TM Type

Instruction Manual

 Read this manual before use of product



Thank you for choosing an Iwaki's EH-Y-TM type pump. This instruction manual deals with the correct installation, operation, maintenance, and troubleshooting procedures for the EH-Y-TM type. Please read through it carefully to ensure the optimum performance, safety and service of your pump.

IMPORTANT INSTRUCTION	1
Safety Section	2
1. INTRODUCTION	5
1-1. Unpacking	6
1-2. Principle of operation	6
1-3. Identification code/Specifications/Functions	7
2. INSTALLATION	14
2-1. Notes on installation	15
2-2. Location	17
2-3. Tubing	18
2-4. Electrical wiring	20
3. OPERATION	23
3-1. Preparation for operation	24
3-2. Operation	27
4. MAINTENANCE	36
4-1. Precautions when pump is disassembled	37
4-2. Diaphragm replacement	37
4-3. Valve replacement	38
4-4. Tubing	38
4-5. Consumable parts	39
4-6. Pump head disassembled view	40
5. Troubleshooting	42
5-1. Troubleshooting	43

Important Instruction

For the Safe and Correct Handling of the Pump

- Read the "Safety Instructions" sections carefully to prevent accidents involving user or other personnel and to avoid damage or loss of other assets. Always follow the instructions and advices written in these sections.
- Observe and abide by the instructions described in this manual. These instructions are very important for protecting pump users from dangerous conditions and situations related with the use of the pump system.
- The symbols and meanings are described below.

 Warning	Nonobservance or misapplication of the contents of the "Warning" section could lead to a serious accident, including death or injury.
 Caution	Nonobservance or misapplication of the contents of the "Caution" section could lead to serious physical injury to the user or serious damage to the product.

Types of Symbols



Indicates that "Warning" or "Caution" must be exercised. Inside this triangle, a concrete and practical image provided as a warning or caution message is depicted.











Indicates a prohibited action or procedure. Inside or near this circle, a concrete and practical image of the activity to be avoided is depicted.











Indicates an important action or procedure which must be performed or carried out without fail. Failure to follow the instructions herein can lead to malfunction or damage to the pump.







Safety Section

 Warning	
<ul style="list-style-type: none"> Turn off the power supply Working without disconnecting the power supply cause an electrical shock. Before engaging upon any working procedures involving the pump, make sure to turn the power supply switch off and to stop the pump and other related devices. 	 Electrical Shock
<ul style="list-style-type: none"> Terminate operation ! When you detect or become aware of a dangerous sign or abnormal condition during operation, terminate the operation immediately and start from the beginning again. 	
<ul style="list-style-type: none"> For specified application only. The use of a pump in any application other than those clearly specified may result in injury or damage to the pump. Use the pump strictly in accordance with the pump specifications and application range. 	 Prohibited
<ul style="list-style-type: none"> No remodeling Never remodel a pump. Otherwise, a serious accident may result. Iwaki will not be responsible for any accident or damage of any kind which is caused by the user remodeling the pump without first obtaining permission or instructions from Iwaki. 	 No Remodeling
<ul style="list-style-type: none"> Wear protectors. If you touch or come in contact with any type of hazardous chemical liquid, including but not limited to chemicals, you may experience a serious injury. Wear protective gear (protective mask, gloves, etc.) during the pump operation. 	 Wear protective gear
<ul style="list-style-type: none"> Operating site must be free of water and humidity. The pump is not designed to be water-proof or dust-proof. The use of the pump in places where water splashes or humidity is high may result in an electrical shock or short circuit. 	
<ul style="list-style-type: none"> Do not charge, disassemble or put in fire the battery which is mounted in the controller of pump. Wrong handling of battery may cause fire, explosion or chemical combustion. 	 Prohibited
<ul style="list-style-type: none"> Stop pump by key operation Pump must be stopped by key operation before the power is disconnected. Wait seven seconds or more until you disconnect the power after the pump operation is stopped by pushing key. If power is disconnected within seven seconds after the pump is stopped, the operation of pump stop may not be memorized and the pump may start running and discharging liquid as soon as the power is connected. 	

Safety Section

 Caution	
<ul style="list-style-type: none"> Qualified operators only The pump operator and pump operation supervisor must not allow any operators who have little or no knowledge of the pump to run and operate the pump. Pump operators must have a sound knowledge of the pump and its operation. 	 Prohibited
<ul style="list-style-type: none"> Specified power only. Do not operate the pump on voltage which is not specified on the nameplate. Failure to do so may result in damage or fire. Only the specified power level is to be applied. 	 Prohibited
<ul style="list-style-type: none"> Do not run the pump dry. Do not run the pump dry (without liquid inside the pump). Heat generated as a result of abrasion between elements inside the pump during operation without liquid may damage the inside of the pump. 	 Prohibited
<ul style="list-style-type: none"> Do not wet or dampen If an electric part or wiring gets wet with the liquid spilled over accidentally, a fire or electrical shock may be caused. Install the system in a place free from liquid spillage or leakage. 	 Do not wet or dampen
<ul style="list-style-type: none"> Ventilate Poisoning may result during an operation which involves, toxic or odorous liquid. Ventilate the operating site sufficiently. 	 Caution
<ul style="list-style-type: none"> Spill-out accident Protective measures should be taken against any accidental spill-out or leakage of the operating liquid as a result of unexpected damage on the pump or the related piping. 	 Caution
<ul style="list-style-type: none"> Damaged pump Never operate a damaged pump. A damaged pump may cause leakage or electrical shock. 	 Prohibited
<ul style="list-style-type: none"> Do not damage or change power cable Do not scratch, damage, process, or pull the power cable forcibly. An extra load onto the cable, such as heating the cable or placing something heavy on the cable, may damage the cable and finally cause a fire or an electrical shock. 	 Caution

Safety Section

 Caution	
<ul style="list-style-type: none">• Arrange grounding Do not operate the pump without connecting the grounding wire. Otherwise, an electrical shock may result. Make sure the grounding wire is connected with grounding terminal.	 Grounding
<ul style="list-style-type: none">• Install an earth leakage breaker The operation of a pump without using an earth leakage breaker may cause an electrical shock. Please install a leakage breaker in the system.	 Electrical Shock
<ul style="list-style-type: none">• Handling of power cable Use of a defective or damaged power cable may result in a fire or electrical shock. Handle the power cable carefully.	 Prohibited
<ul style="list-style-type: none">• Follow the instruction manual Replace the consumable part by following the descriptions in the instruction manual. Do not disassemble any part of the pump if the disassembling procedure for the part in question is not included in the instruction manual.	
<ul style="list-style-type: none">• Limited operating site and storage Do not install or store the pump in the following places : Places where a flammable gas or material is used or stored. Places where the ambient temperature is extremely high (40°C or higher) or extremely low (0°C or lower).	 Prohibited
<ul style="list-style-type: none">• Disposal of used pump Disposal of used or damaged pumps must be done in accordance with the relevant local law and regulations. (Consult a licensed industrial waste products disposing company.)	

1. INTRODUCTION

<i>1-1. Unpacking</i>	<i>6</i>
<i>1-2. Principle of operation</i>	<i>6</i>
<i>1-3. Identification codes/Specifications/Functions</i>	<i>7</i>
<i>1-3-1. Pump identification</i>	<i>7</i>
<i>1-3-2. Controller identification</i>	<i>8</i>
<i>1-3-3. Pump specification</i>	<i>9</i>
<i>1-3-4. Controller specification</i>	<i>10</i>
<i>1-3-5. Operation function</i>	<i>10</i>
<i>1-3-6. Controller function</i>	<i>12</i>

1-1. Unpacking

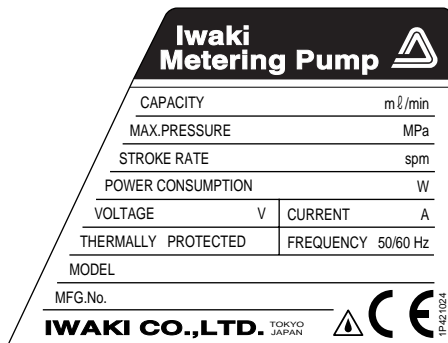

After unpacking the goods, check the following points to ascertain that the product is exactly as you ordered. If you find anything wrong, please get in touch with your dealer.

- (1) The model symbol shown on nameplate represents ordered one.
- (2) The pump is not damaged and bolts are not loosened during transportation.

1-2. Principle of Operation

The EH Series electronic metering pump consists of a pump unit, a drive unit, and a control unit. The drive unit is an electromagnetic solenoid. When the solenoid coil is energized by the control unit the armature shaft moves forward due to the magnetic force of the solenoid. The shaft is attached to a PTFE faced diaphragm which is part of the pump unit. The diaphragm is forced into the pump head cavity decreasing volume and increasing pressure which forces liquid in the pump head out through the discharge check valves. When the solenoid coil is de-energized, a spring returns the armature to its starting position. This action pulls the diaphragm out of the head cavity increasing volume and decreasing pressure. Atmospheric pressure then pushes liquid from the supply tank through the suction check valves to refill the pump head.

1-3. Identification Codes/Specifications/Functions

1-3-1. Pump identification

EH - B 10 VC - 20E P Y 2 - TM -

(1) (2) (3) (4) (5) (6) (7) (8) (9) (10)

(1) Series name : EH Series

(2) Drive component

B : 16W C : 24W

(3) Effective diameter of diaphragm

10 : 10mm 15 : 15mm 20 : 20mm 30 : 30mm 35 : 35mm

Note: B15, B30 and C15 are not available for material symbol FC and SH.

(4) Material of liquid end

Symbol	Pump head & Fittings	Valve	Valve seat	O-ring (Gasket)	Diaphragm	Gasket
VC	PVC	CE	FKM	FKM	PTFE + EPDM	PTFE
VH	PVC	HC	EPDM	EPDM		
PC	GFRPP	CE	FKM	FKM		
PH	GFRPP	HC	EPDM	EPDM		
FC	PVDF	CE	PCTFE	PTFE		
SH	SUS316	HC	SUS316	(PTFE)		

PVC : Polyvinyl chloride
 GFRPP : Glass fiber reinforced polypropylene
 PVDF : Polyvinylidene fluoride
 SUS316 : Stainless steel 316
 CE : Alumina ceramic
 HC : Hastelloy C276
 FKM : Fluoroelastomer
 EPDM : Ethylene propylene diene methylene
 PTFE : Polytetrafluoroethylene
 PCTFE : Polychlorotrifluoroethylene

(5) Power source

Symbol	Voltage	Input voltage	Frequency
20E	AC220V, 230V, 240V	AC198V - 264V	50 - 60Hz
100	AC100V, 110V, 115V	AC90V-126V	50 - 60Hz

(6) Power code

P : with plug

No symbol : Crimp style terminal

(7) Controller

Y : Y type

(8) Connection

Symbol	Applicable hose dia. (ID×OD)	Liquid end material symbol
1	4 × 9 mm	VC, VH, PC, PH
2	4 × 6	VC, VH, PC, PH, FC
3	6 × 8	VC, VH
4	8 × 13	VC, VH, PC, PH
5	9 × 12	VC, VH, PC, PH
6	10 × 12	FC
9	Rc 1/4 inch	SH

(9) TM : Timer type controller

(10) Special version symbol

1-3-2. Controller identification

EH-C - B 20E P Y - TM - □□
(1) (2) (3) (4) (5) (6) (7)

(1) Controller name : EH Controller

(2) Drive component symbol

Symbol	Average power consumption (W)
B	16
C	24

(3) Power source

Symbol	Voltage	Input voltage	Frequency
20E	AC220V, 230V, 240V	AC198V - 264V	50 - 60Hz
100	AC100V, 110V, 115V	AC90V - 126V	50 - 60Hz

(4) Power cord

P : With plug

No symbol : Crimp-style terminal

(5) Controller

Y : Y type

(6) TM : Timer type

(7) Special version symbol

Points to be noted in handling

1. Do not detach the control unit unless unavoidable.

2. Never use the control unit with pumps having different symbols for driving unit and power source voltage specified on the control unit. (Check the nameplate.)

Caution

Operation with a pump having different symbols for driving unit and power voltage other than specified ones may cause failure or trouble in the electronic circuit of the control unit or the driving unit.

1-3-3. Pump specification

VC, VH, PC, PH type

Model	Capacity (ml/min.)	Capacity (ml/stroke)	Max. pressure (MPa)	Stroke frequency (spm)	Stroke length mm (%)	Average power consumption (W)
EH-B10	38	0.04 ~ 0.11	0.98	0 ~ 360	0.4 ~ 1 (40 ~ 100)	16
B15	70	0.04 ~ 0.19	0.69		0.2 ~ 1 (20 ~ 100)	
B20	105	0.06 ~ 0.29	0.39			
B30	230	0.13 ~ 0.64	0.20		0.25 ~ 1.25 (20 ~ 100)	24
C15	90	0.05 ~ 0.25	0.98			
C20	130	0.07 ~ 0.36	0.69			
C30	270	0.15 ~ 0.75	0.34			
C35	450	0.25 ~ 1.25	0.20			

FC, SH type

Model	Capacity (ml/min.)	Capacity (ml/stroke)	Max. pressure (MPa)	Stroke frequency (spm)	Stroke length mm (%)	Average power consumption (W)
EH-B10	38	0.04 ~ 0.11	0.98	0 ~ 360	0.4 ~ 1 (40 ~ 100)	16
B20	95	0.05 ~ 0.26	0.39		0.2 ~ 1 (20 ~ 100)	
C20	120	0.07 ~ 0.33	0.69			0.25 ~ 1.25 (20 ~ 100)
C30	260	0.14 ~ 0.72	0.34			
C35	410	0.23 ~ 1.14	0.20			

Note 1. The performance data is based on pumping clean water at 25 deg. C under rated voltage.

Note 2. Capacity is at max. pressure, max. stroke length and max. stroke frequency.

Capacity exceeds above value when pump operates at low pressure.

Note 3. Operating ambient temperature : 0 ~ 40 deg. C

Note 4. Liquid temperature : Type VC, VH : 0 - 40 deg. C Type PC, PH, FC, SH : 0 - 60 deg. C

Note 5. Permissible voltage fluctuation : Within plus minus 10% of rating

Note 6. Recommended stroke length adjustment range : 20% to 100%

Recommended frequency adjustment range : 0 to 360 spm

1-3-4. Controller specification

Operation function	Operation mode	Timer control
		Wait
		Manual operation
	Switching	By MODE key
Control function	Setting	<ul style="list-style-type: none"> Control method : Daily Weekly 2 Weekly Timer setting : Start time, Operation time, Day of week Time adjustment : 0.00 - 23.59, Day of week Stroke rate : 1 - 360 spm
	Setting method	Four keys MODE, ▲ (UP/HOUR), ▼ (DOWN/MIN.), SEL (SELECT)
	Stop	Pump stops when contact input comes.
Display	Data	LCD, 4-digit, Operation condition, Set values
	Pump operation	Green LED (Synchronous with stroke)
Input	Stop	Potential free contact or open collector (Note 1)
Time	Accuracy	Plus minus 1 min./mon. (at amb. temp. 25 deg. C) (Note 2)
	Compensation for interrupted power	5 years (Accumulated time of interrupted power.) (Note 3)
Power source voltage		Identification code 100 : AC90 - 126V 50/60Hz 20E : AC198 - 264V 50/60Hz

Note 1. Max. charged voltage and amperage to the contact 5V and 1.1mA.

If the contact such as relay is used, use the one of which the min. applicable load is 1mA or below.

Note 2. The error may be more than plus minus 1 min. depending on the used condition.

Note 3. The controller contains a back up battery for time. 5 years compensation for the accumulated time of interrupted power depends on the used condition. Replace controller when the battery is consumed.

1-3-5. Operation function

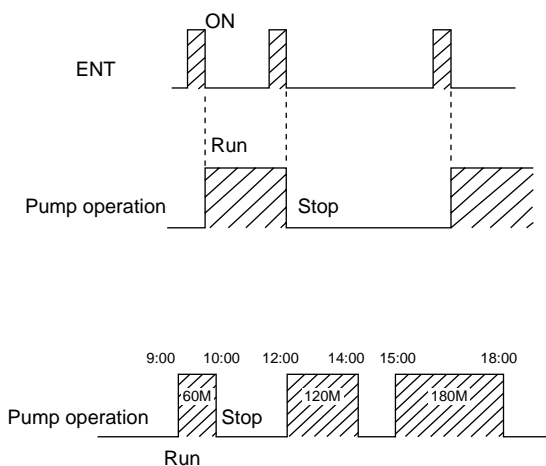

● Manual operation

Set the stroke rate of 0 to 360 spm by ▲ key and ▼ key. Pump stopping and starting are done by SEL key. Stroke rate setting can be done either one when the pump stops or it runs.

● Daily operation

Operation of the same time schedule every day. Up to eight times a day operation.

Illustration on left shows the pump starts first time at 9:00 for 60 minutes running, second time at 12:00 for 120 minutes running and third time at 15:00 for 180 minutes running.

Pump runs at stroke rate which is set by manual operation mode.

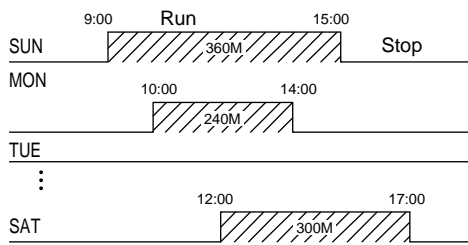

- Weekly operation

Operation of different time schedule for every day. Operation once a day. Illustration on left shows the pump starts at 9:00 for 360 minutes running on Sunday, at 10:00 for 240 minutes running on Monday, at 12:00 for 300 minutes on Saturday and no operation for Tuesday to Friday. Pump runs at stroke rate which is set by manual operation mode.

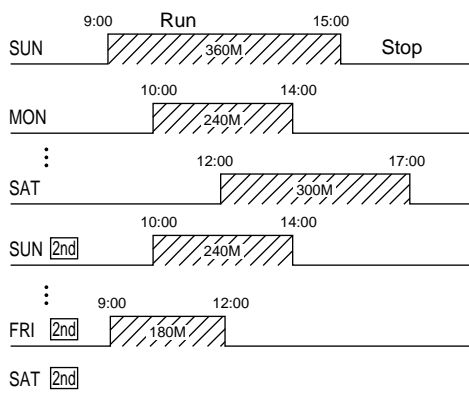

- 2 weekly operation

Two weeks time schedule can be set in the same manner of above item of weekly operation. Illustration on left is an example.

1-3-6. Controller function

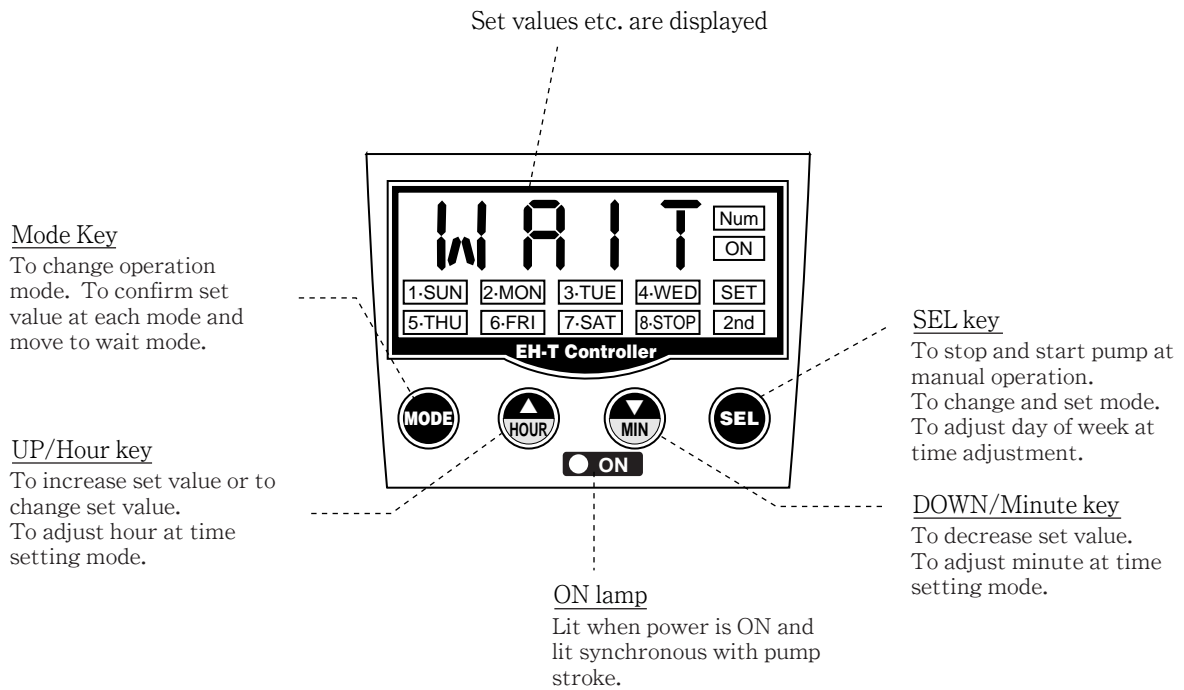

- Controller display



Symbols on display window

- 1·SUN Lit on Sunday or when Sunday is set or for the first operation of daily operation.
- Num When this is lit, it means the number "1" is employed on the above symbol 1·SUN
- ON Lit when pump operates at manual mode or pump started when set time has come.
- 2nd Lit at the second week of 2 weekly operation.
- SET Lit while any setting is done.
- STOP Lit when pump stops because stop signal came in.

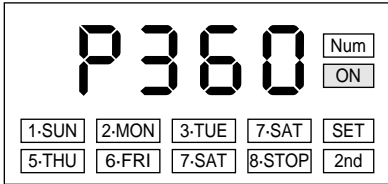
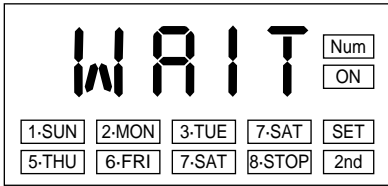
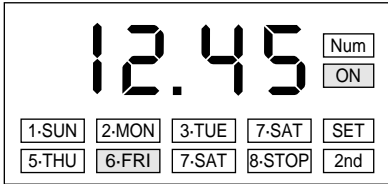
● Basic display

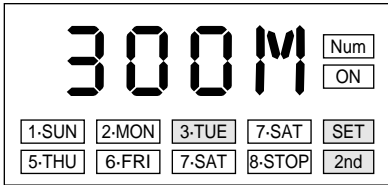
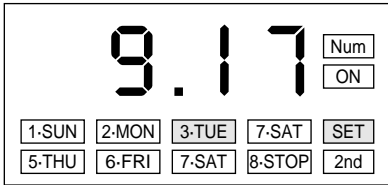
Display	Meanings
	<p>Running at manual operation mode. The value shows set value of spm.</p>
	<p>At wait mode.</p>
	<p>Running by timer control on Friday at time 12:45.</p>
	<p>Being set for cycle. WEEKLY is selected.</p>
	<p>Being set for the second week on Tuesday for operating time of 300 minutes.</p>
	<p>Time is being adjusted at 9:17 on Monday.</p>

2. INSTALLATION

2-1. Notes on installation	15
2-2. Location	17
2-3. Tubing	18
2-3-1. Tubing for VC, VH, PC, PH, FC types ..	18
2-3-2. Tubing for SH type	19
2-4. Electrical wiring	20
2-4-1. Precautions on wiring	20
2-4-2. Wiring	21

2-1. Notes on installation

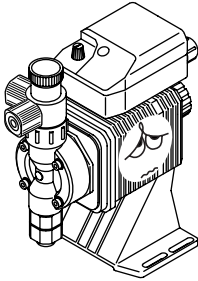
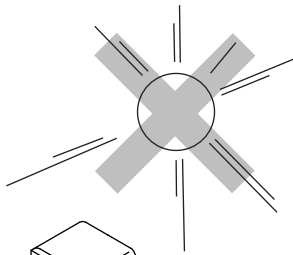
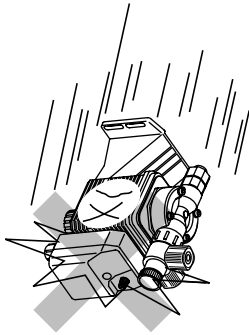

Prohibited

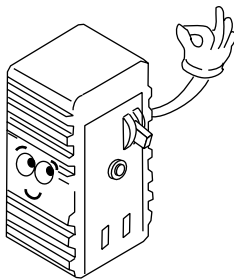

Caution

- Dropping the pump or subjecting it to strong impacts may result in faulty performance. Handle the pump with care.

- The pump can be operated outdoors, as the pump employs a simple water and dustproof structure.

When installing the pump, avoid places exposed to direct sunlight or direct rain with an ambient temperature of above 40 deg. C, or with a relative humidity of above 85%. Though the pump has a simple waterproof and dustproof structure, a sheltered location is recommended.

- Select an installation site convenient for future maintenance and inspection, and fix the pump on a level floor so that it is free of vibrations.

- Ventilate
Positioning may result during an operation which involves toxic or odorous liquid. Ventilate the operating site sufficiently.

- Do not wet or dampen
If an electric part or wiring gets wet with the liquid spilled over accidentally, a fire or electrical shock may be caused. Install the system in a place free from liquid spillage or leakage.

- Install an earth leakage breaker (option)
The operation of a pump without using an earth leakage breaker may cause an electrical shock. Please purchase an optional leakage breaker and install in the system.

- The control unit can be detached. However, it should not be detached unless unavoidable. Never use the detached control unit with other pump models.



- Arrange grounding

Do not operate the pump without connecting the grounding wire. Otherwise, an electrical shock may result. Make sure the grounding wire is connected with the grounding terminal.

- Limited operating site and storage

Do not install or store the pump in the following places:

- * Place where a flammable gas or material is used or stored.
- * Place where the ambient temperature is extremely high (40 deg. C or higher) or extremely low (0 deg. C or lower).

- Cleaning

Wiping the pump body or the nameplate with a cloth soaked in a solvent such as benzene, thinner or kerosene may remove or change the color of the coating. Use a dry cloth or a cloth soaked in water or neutral detergent.

- If the pump is used for industrial purpose, the electric power cable of the pump must be installed in the enclosure which satisfies IP66 or in the atmosphere corresponding to IP66.

2-2. Location

Choose a location for the pump which is clean, dry, close to an electrical outlet, and allows convenient access to stroke length control, frequency control, and tubing connections. Avoid areas where ambient temperature exceeds 40 deg. C or falls below 0 deg. C, or where the pump or tubing would be exposed to direct sunlight. Flooded suction (mounting the pump below the level of liquid in the supply tank) is strongly recommended, especially when pumping liquids that readily generate gas bubbles. Sodium hypochlorite and hydrogen peroxide are common examples of such liquids.

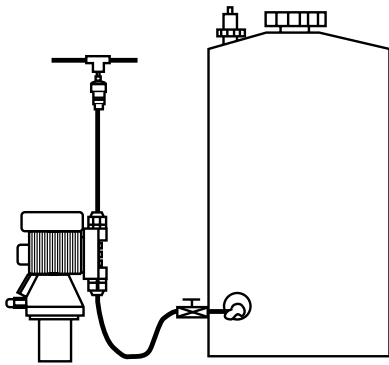

Figure 1
Flooded Suction

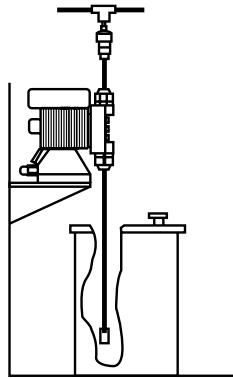

Figure 2
Shelf Mount

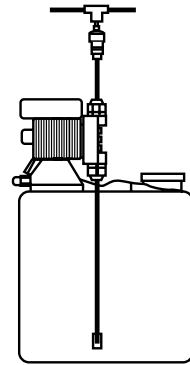

Figure 3
Tank Mount

(See Figure 1.)

If flooded suction mounting is not possible, a shelf adjacent to (but not directly above) the supply tank often works well. (See Figure 2.) The supply tank or cover can also be used if it has provisions for mounting a pump. (See Figure 3.) In any case, the total suction lift should not exceed 1.5m.

2-3. Tubing

2-3-1. Tubing for VC, VH, PC, PH, FC types

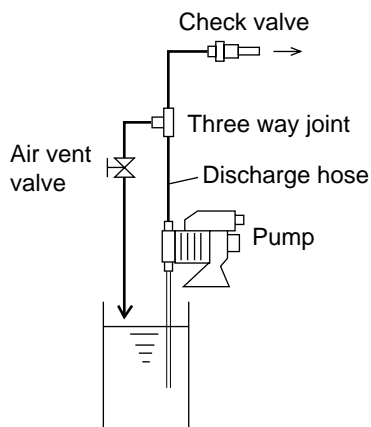
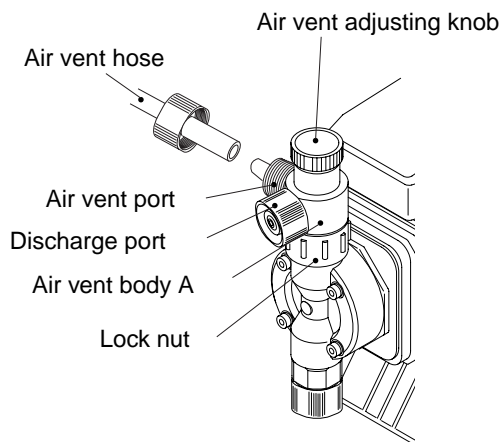
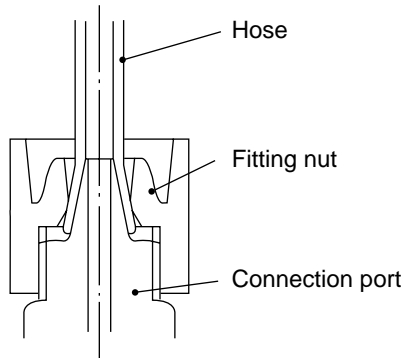

- (1) Put the hose on the connection port and tighten the fitting nut by hand and tighten it by a half turns with a wrench.

⚠ Caution

Plastic made fitting nut may be broken if tightened excessively.

- (2) Connect a tube to the air vent port. Return the hose end to the tank.
- (3) Adjust the direction of air vent port. It can be oriented to any direction.
 - a. Loosen the lock nut turning it counterclockwise with wrench.
 - b. Put the air vent in the direction as you like.
 - c. Tighten the lock nut by hand holding the air vent body A by hand.
 - d. Tighten the lock nut by 1/4 turns with wrench.

⚠ Caution

EH-30, 35 and FC type do not equip with the built-in air vent valve. Install it as shown on left.

2-3-2. Tubing for SH type

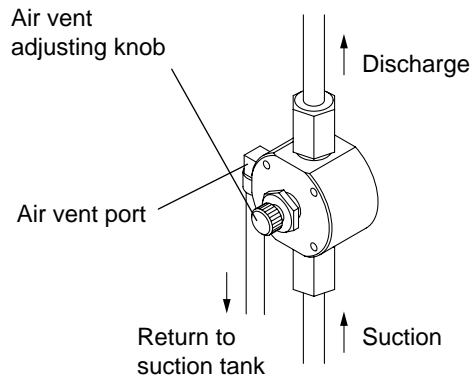

- (1) Mounting of air vent port
Apply seal tape to the attached air vent port and mount it to the pump head.
- (2) Piping must be as short and less bends as possible to reduce the pipe resistance.
- (3) Suction and discharge ports are Rc1/4 female threads. Suction and discharge piping should be securely connected so that the air can not be sucked in or the liquid can not leak.
- (4) Air vent piping
When bleeding is done, do not fail to connect the hose to the air vent port and return it to the suction tank.

2-4. Electrical wiring

2-4-1. Precautions on wiring

Caution

Only qualified operators/service staff should be in charge of the related electrical arrangement and control of the power source. Failure to observe this instruction may result in injury to person or damage to assets.

Check these points before wiring

- (1) Check if the main power supply is turned off (power is not supplied).
- (2) Carry out wiring in accordance with the regulations concerning electrical work.
(Use qualified wiring materials and carry out wiring in accordance with the technical standards of electrical installation.)

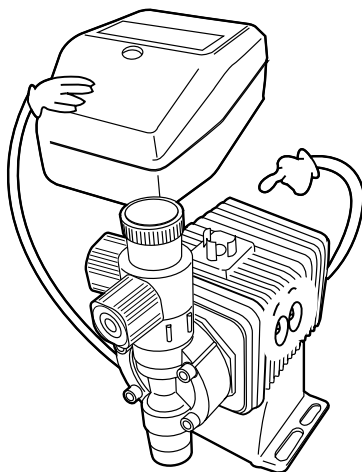
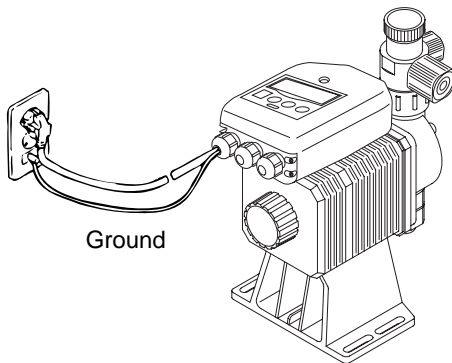

- (3) Grounding must be arranged without fail.
- (4) Though the control unit can be easily detached from the pump driving section, the power voltage and driving section specifications differ from one pump type to another. Never use the detached control unit in combination with a pump which is different from the one that you purchased together with the control unit. Otherwise, the electronic circuit or the pump driving section may be damaged.
- (5) Never supply power to the system by connecting the power supply cable to the service outlet which also supplies power to high-power electrical equipment that generates surge voltage. Otherwise the electronic circuit may be damaged. In addition to the above, be careful concerning the effect of noise generated by the inverter or other noise generating mechanisms.

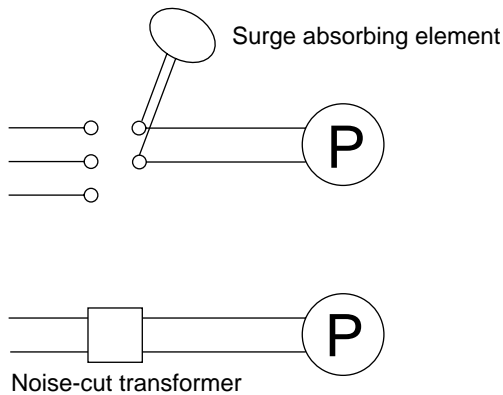

● Surge voltage

The electronic circuit of the control unit may be affected by excessively high surge voltage. So, do not operate the pump near high-power electrical equipment of 220V or above that generates high surge voltage.

Under unavoidable circumstances, take either of the following measures.

- (1) Use a surge absorbing element (such as a varistor with surge resistance of 2000A or more) at the pump power supply connection.
- (2) Use a noise-cut transformer.

2-4-2. Wiring

Connect the external signal wires as shown below.

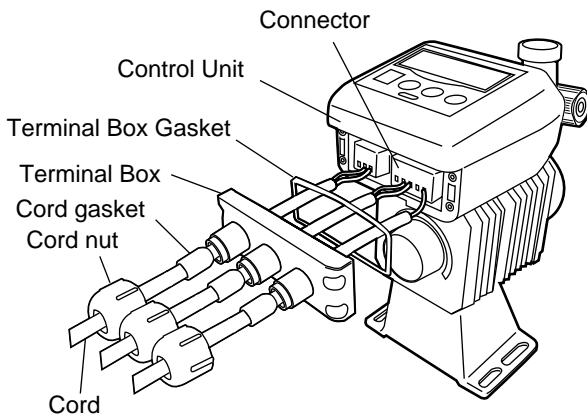

Connector for power cord

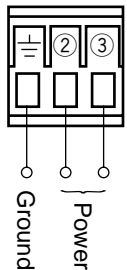

Connector for stop signal cord

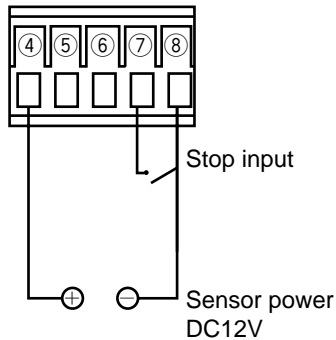

- (1) Remove four screws to remove a terminal box.
- (2) Remove a connector.
- (3) Remove a cord nut, a blind cap and a cord gasket, and insert the signal cord into the nut and cord gasket.

⚠ **Caution**

Use the signal cord of outer diameter of 7.8 mm. If other diameter cord is used, perfect sealing can not be obtained resulting in malfunction of the controller.

- (4) Connect the wires to the connector. Insert the wire end by 5 mm into the terminals and tighten the connector screws. (Tightening torque approx. 0.4 N·m)
- (5) After the wire are connected, insert the connector into the socket.

⚠ **Caution**

Make sure the connector is securely inserted into the socket. If not, malfunction may occur.

- (6) Mount the terminal box and fix it with screws.
- (7) Adjusting the tension of the cord inside the box, put the cord gasket into the terminal box.
- (8) Tighten the cord nuts.

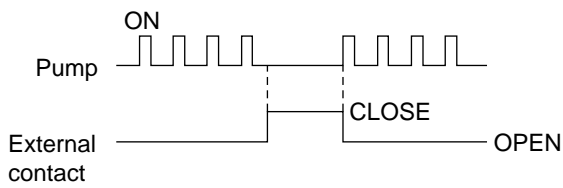
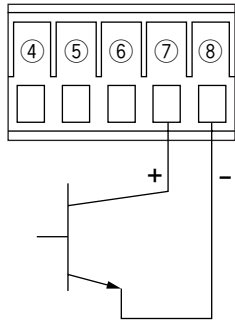

- Wiring for stop function

Stop function means the method to provisionally stop the pump operation by external potential free contact signal or open collector signal.

For the wiring, connect the wires to ⑦ and ⑧ of the connector.

- When used with open collector

Pay attention to the polarity. ⑦ is plus and ⑧ is minus. (Max. chargeable voltage is 5V, current 1.1 mA)

- When used with mechanical contact such as relay or so

Use the electronic purpose one of which the minimum applicable load of 1 mA or below.

3. OPERATION

3-1. Preparation for operation	24
3-1-1. Bleeding	24
3-1-2. Adjustment of discharge capacity	25
3-2. Operation	27
3-2-1. Overview operating scheme	27
3-2-2. Setting and operation of pump	28

3-1. Preparation for operation

Caution

- Do not operate the pump with discharge-side valve completely closed.
Operating the pump with discharge-side valve fully closed may lead to liquid leakage or pipe rupture.
- Do not run pump dry.
Dry operation of the pump over a long time (longer than 30 minutes) causes the pump to overheat and the pump unit (pump head, valve guide etc.) to become deformed or the pump head attachment to become loose, which may result in liquid leakage trouble.
- Keep the pump head firmly assembled.
If mounting bolts on the pump head are loosened, liquid leakage may result.
* Fasten the 4 hex. socket bolts tightly before starting the initial pump operation. (The bolts may be loosened during storage or transportation of the pump, depending upon the condition.)
* Fastening torque: 2.16 N*m.
Tighten all the bolts fully by applying an equal amount of torque in a diagonal order among the bolts.

3-1-1. Bleeding

Bleeding is a process undertaken to eliminate air inside the suction side tube and pump head. Make sure to carry out the bleeding prior to initial operation of pump.

1) Bleeding for models EH-B10, 15, 20, C15, 20 and all models of SH type.

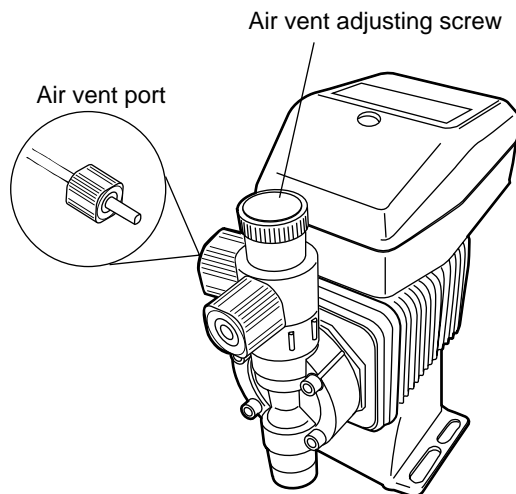

- a. First of all connect a tube to air-vent port of air vent unit.
- b. Put plug in outlet.
- c. Power ON the pump.
- d. Start pump according to the procedure "3-2-2. Setting and operation of pump-manual operation" on page 28.
- e. Turn air vent adjusting screw counterclockwise (almost half a turn) to open air vent port.
- f. Operate pump about ten minutes to eliminate air completely.
- g. Turn the adjusting screw clockwise to close air vent valve.

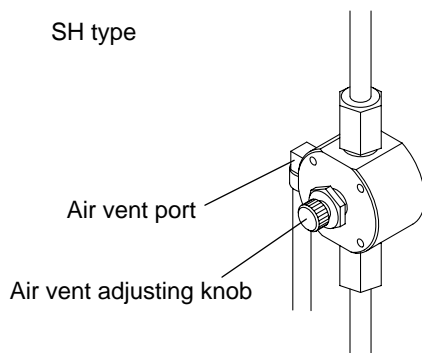

- 2) Bleeding for models EH-B30, C30, C35, FC types.
 (Air vent unit is not equipped for models B30, C30, C35 and all models of FC type.)
- Put a tube to discharge side fitting nut.
 - Set stroke length at 100% and frequency at 360 spm.
 - Start pump and operate about ten minutes to eliminate air completely.
 - When liquid enters the discharge tubing at the pump head, stop pump operation.

3-1-2. Adjustment of discharge capacity

Adjustment of the discharge capacity can be done by adjusting the stroke length and by adjusting the stroke rate but basically it is done by adjusting the stroke rate. Stroke length adjustment is an auxiliary way when the stroke rate adjustment is not enough.

Pay attention to the followings for the correct adjustment.

- For the gaseous liquid such as sodium hypochlorite and hydragine solution, set the stroke length at 100 % or near. Discharge flow may be reduced if the stroke length is short.
- When the back pressure is high at discharge side, set the stroke length at 100 % or near.

1. Procedure to adjust the discharge capacity

Appropriate stroke length and stroke rate are decided considering the pump operating condition and liquid characteristics or so. Following ways are recommended for proper calibration.

- Set the stroke length at 100% to roughly adjust the discharge capacity by adjusting the stroke rate.
- Measure the discharge capacity.
- If the measured capacity is below the wanted value, increase the stroke rate and measure again the discharge capacity.
- Adjust the stroke length to do the fine adjustment of the capacity.
- Measure again the discharge capacity to confirm the wanted capacity is discharged.

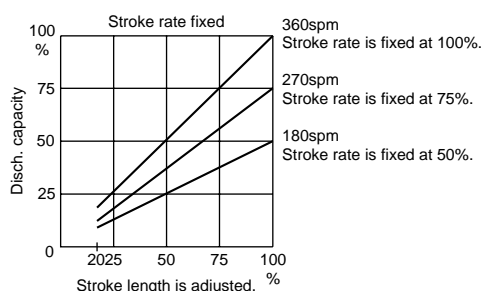

2. Adjustment of stroke rate

Stroke rate is adjusted by keys operation on the control unit. Stroke rate is adjusted from 1 to 360 spm. See the item 3-2-2. Setting and operation of controller on page 29 for stroke rate adjustment method.

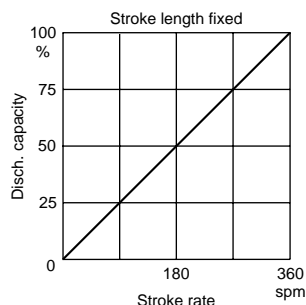
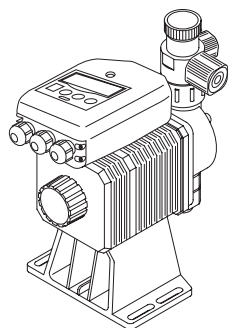

3. Adjustment of stroke length

- (1) Power on the pump to start and adjust the discharge capacity by turning the stroke length adjustment knob.
- (2) Figure below shows the relation between the stroke length and discharge capacity.
Stroke length can be adjusted from 0 to 100 % but actually set the length between 50 and 100 %.

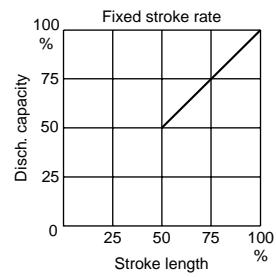
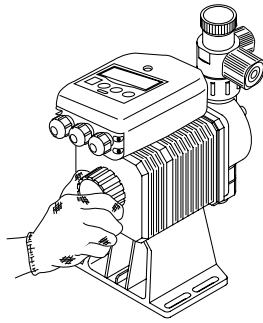

⚠ Caution

Do not turn the stroke length adjusting knob while pump stops.

3-2. Operation

3-2-1. Overview operating scheme

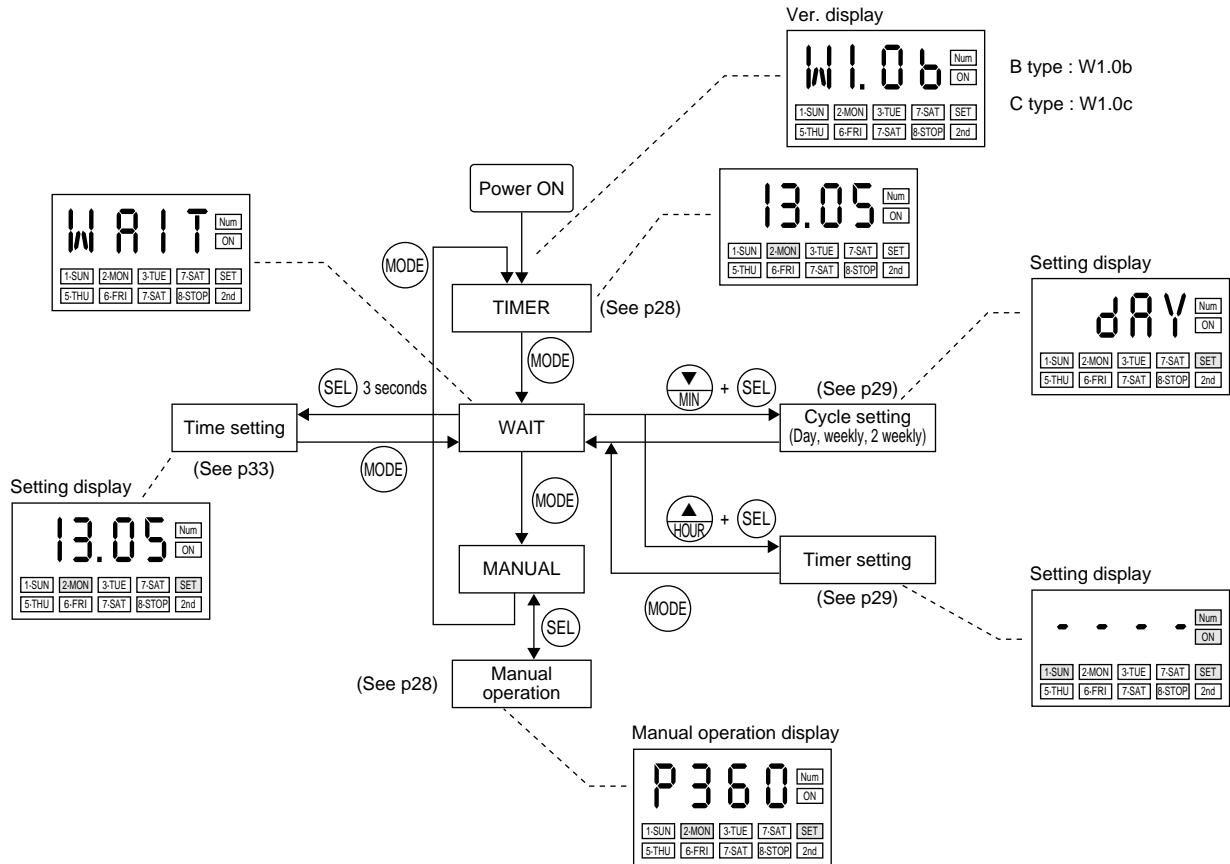

Notes to Overview Operating Scheme

- 1) -----> means automatic movement. It automatically moves to the status at which the power was off last time. (If the power was off while setting, it comes to WAIT mode.) When the pump is powered for the first time, it comes to WAIT mode.
- 2) To start pump by manual operation, push SEL key at manual mode. To stop the pump, push SEL key again.
- 3) Change of operation mode is done by MODE key. Every time MODE key is pushed, mode is changed in the order of WAIT, MANUAL and TIMER.
- 4) To set the cycle (day, weekly or 2 weekly) of timer operation, push ▼ key and SEL key simultaneously at WAIT mode.
- 5) To set the timer of timer operation, push ▲ key and SEL key simultaneously.

3-2-2. Setting and operation of pump

1) Manual operation

(1) Power ON

When power is ON, the display momentarily shows Version display and goes to WAIT mode (When the pump is powered for the first time). On and after the second time, it comes to the mode at which the pump was powered off last time.

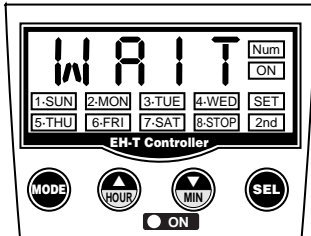

(2) Move to manual mode

Push MODE key once to come to manual mode from wait mode. Push MODE key twice to come to manual mode from timer mode.

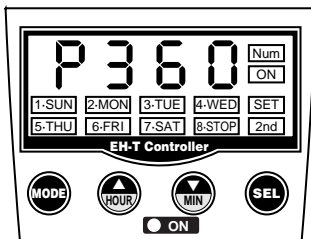

(3) Set stroke rate

Set stroke rate by ▲ key and ▼ key. Figures change quickly if the keys are pushed three seconds or more.

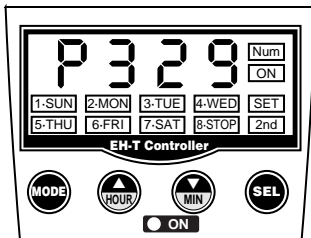

(4) Start

To start pump, push SEL key once. If SEL key is pushed again, pump stops. Stroke rate can be changed while pump runs by the above procedure (3).

While pump is running, it can not move to other mode even if you push MODE key.

⚠ Caution

Pump must be stopped by key operation before the power is disconnected. Wait seven seconds or more until you disconnect the power after the pump operation is stopped by pushing key. If power is disconnected within seven seconds after the pump is stopped, the operation of pump stop may not be memorized and the pump may start running and discharging liquid as soon as the power is connected.

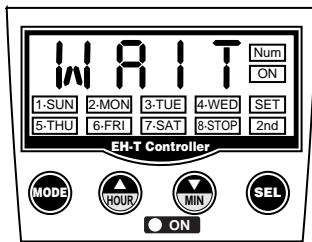

2) Timer operation

(1) Power ON

When power is ON, the display momentarily shows version display and goes to WAIT mode (When the pump is powered for the first time). On after the second time, it comes to the mode at which the pump was powered off last time.

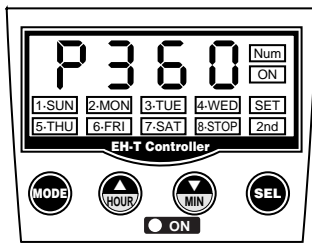

(2) Move to manual mode

Push MODE key to come to manual mode because the stroke rate at timer operation is the same as that of manual operation.

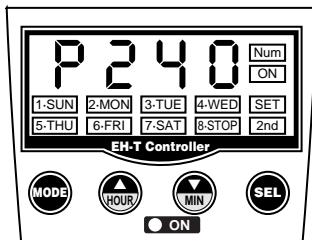

(3) Set stroke rate

Set stroke rate by ▲ key and ▼ key. Figures change quickly if the keys are pushed three seconds or more.

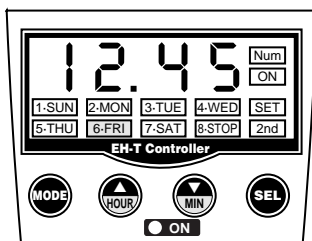

(4) Go to timer operation mode

Push MODE key once to go to timer mode from manual mode and to start operation. To stop the pump, push MODE key once to come to WAIT mode. For timer operation, it is needed that you correctly set cycle setting, timer setting and current time setting.

Refer to following items for details.

3) Cycle setting

(1) Move to WAIT mode

Push MODE key to move to WAIT mode if it is in timer mode or manual mode.

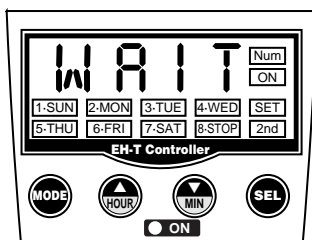

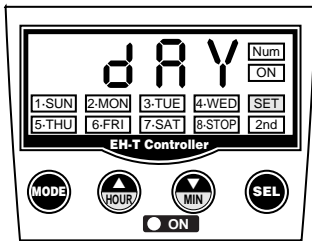

- (2) Move to cycle setting mode

Push SEL key and ▼ key simultaneously to come to cycle setting mode.

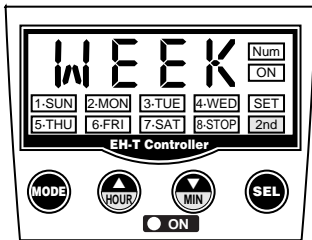

- (3) Select cycle (day, weekly or 2 weekly)

Select any one of cycle of DAY, WEEKLY, 2 WEEKLY by ▲ key and ▼ key. Illustration on left shows 2 WEEKLY.

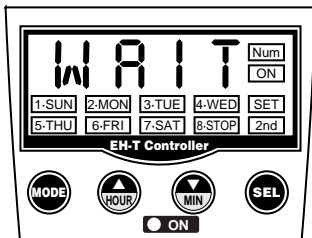

- (4) Push MODE key to confirm and move to WAIT mode.

4) Timer setting

- (1) Move to WAIT mode

Push MODE key to go to WAIT mode if it is in timer operation mode or in manual mode.

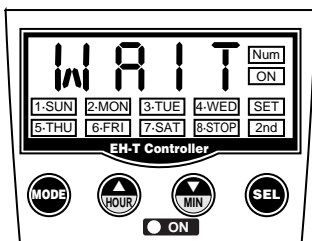

When DAILY is selected for cycle setting

- (2) Move to timer setting mode from WAIT mode by pushing SEL key and ▲ key simultaneously.

1·SUN lights. For the first time setting or if cycle setting is changed, it displays “-----” as shown left.

When Num lights, it means the number “1” is employed in the symbol 1·SUN

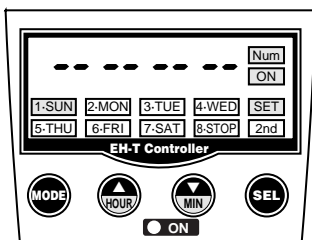

- (3) Set start time

Set start time by ▲ key (1 hour gain by one push) and ▼ key (1 minute gain by one push).

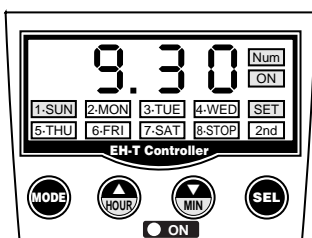

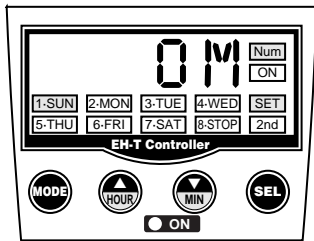

(4) Push SEL key to go to operating time setting.

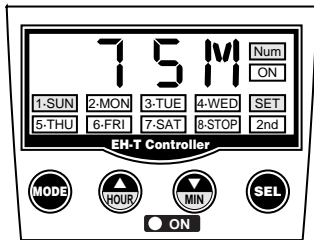

(5) Set operating time

Set operating time (minute) with ▲ key and ▼ key.
("M" on the display means minute.)

Push SEL key to move to the setting of the second operating time.

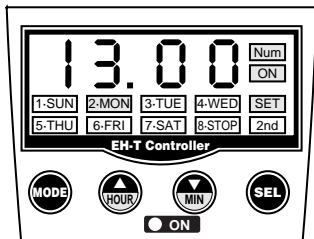

(6) Set the second starting time

2-MON lights. Set starting time by ▲ key and ▼ key in the same manner as items (2) and (3).

Push SEL key to move to next step.

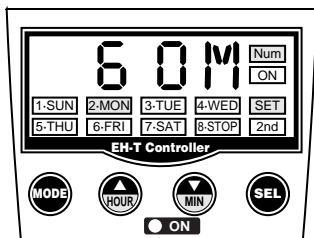

(7) Set the second operating time

Set the operating time by ▲ key and ▼ key.

Push SEL key to move to the third setting.

In the same manner you can set the starting time and operating time up to eighth times a day.

If you wish to do the setting all over again or if you wish to confirm the setting you did, push SEL key to return the procedure (3).

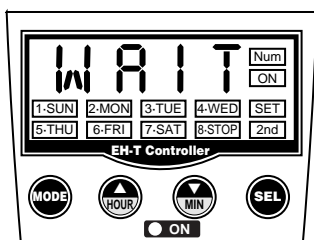

(8) When setting is finished, push MODE key to confirm the setting and to move to WAIT mode.

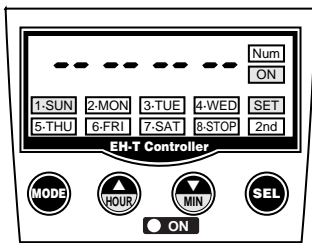

When WEEKLY is selected for cycle setting

- (2) Move to timer setting mode from WAIT mode by pushing SEL key and ▲ key simultaneously.

1·SUN lights. For the first time setting or if cycle setting is changed, it displays “- - - - -” as shown left.

When Num does not light, it shows the day of week (SUN) is employed in the symbol 1·SUN but not the number “1”.

If you do not set for Sunday, push SEL key to go to next day of the week (5).

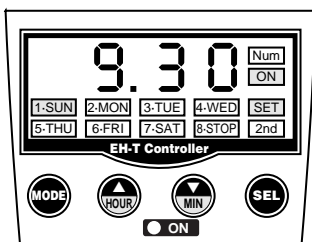

- (3) Set starting time on Sunday

Set starting time by ▲ key and ▲ key.

Push SEL key to go to next.

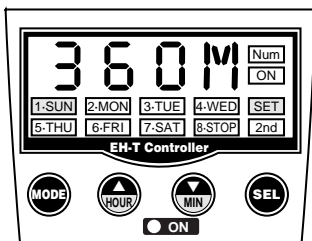

- (4) Set operating time on Sunday

Set operating time on Sunday by ▲ key and ▼ key.

Push SEL key to go to next step.

If you do not need to set for Monday or later, push MODE key to confirm.

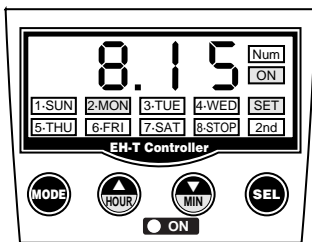

- (5) Set starting time on Monday

Set starting time on Monday by ▲ key and ▼ key.

Push SEL key to go to next step.

If you do not set the program for Monday, push SEL key to go to next step.

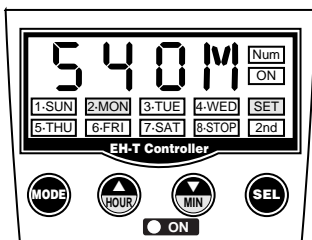

- (6) Set operating time on Monday

Set operating time by ▲ key and ▼ key.

Push SEL key to go to next step.

Set the program till Saturday according to the procedures as mentioned above.

If you wish to do the setting all over again or you wish to confirm the setting you did, push SEL key to return the procedure (3).

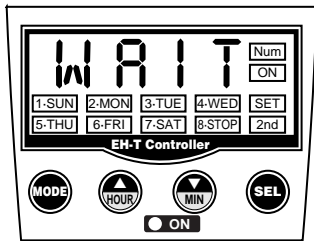

(7) Push MODE key to confirm and return to WAIT mode.

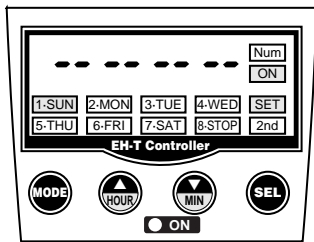

When 2 weekly is selected

(2) Move to timer setting mode from WAIT mode by pushing SEL key and ▲ key simultaneously.

1·SUN lights. For the first time setting or if cycle setting is changed, it displays “-----” as shown left.

When Num does not light, it shows the day of week (SUN) is employed in the symbol 1·SUN but not the number “1”.

If Sunday of the first week is not set, push SEL key to go to next day of the week (5).

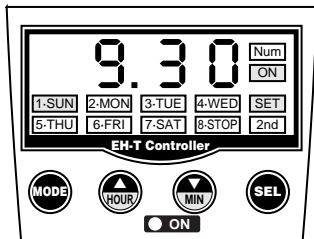

(3) Set starting time on the first Sunday
Set starting time by ▲ key and ▼ key.

Push SEL key to go to next step.

If you do not set for Sunday, push SEL to go to next step.

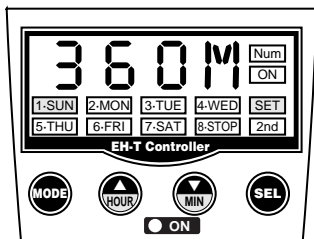

(4) Set operating time on the first Sunday
Set operating time by ▲ key and ▼ key.

Push SEL key to go to next step.

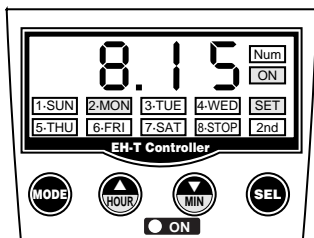

(5) Set starting time on the first Monday
Set starting time by ▲ key and ▼ key.

Push SEL key to go to next step.

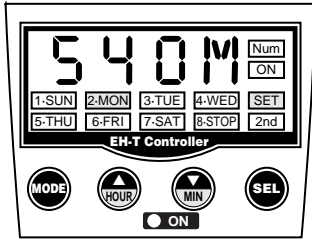

- (6) Set operating time on the first Monday
Set operating time by ▲ key and ▼ key.

Push SEL key to go to next step.

If you wish to skip any day of the week, push SEL key until comes the day of the week you wish.

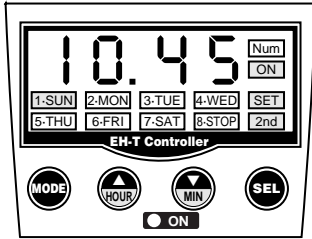

- (7) Set for each day in the same manner as (5) and (6).

For Sunday of the second week, is lit.

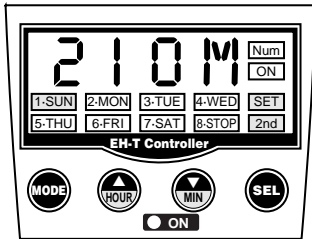

- (8) Set operating time on Sunday of the second week

Set operating time by ▲ key and ▼ key.

Push SEL key to go to next step.

Set the program till Saturday according to the procedures as mentioned above.

If you wish to do the setting all over again or you wish to confirm the setting you did, push SEL key to return the procedure (3).

If you do not want to go ahead any more, push MODE key confirm the setting.

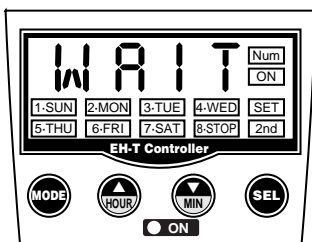

- (9) Push MODE key to confirm and return to WAIT mode.

5) Time setting

⚠ Caution

Time is set at Japan time when the pump was shipped.
Check the time before you use the pump.
Correct operation can not be done if time or day of the week are set wrong.

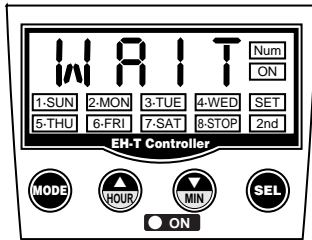

- (1) Set to WAIT mode
Push MODE key to go to WAIT mode.

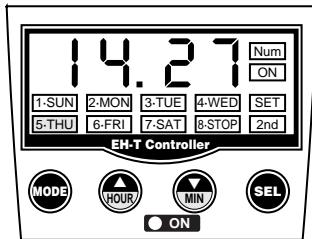

- (2) Go to time setting mode
Push SEL key three seconds or more for time display.

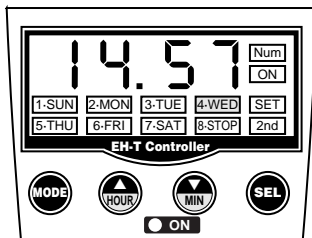

- (3) Set time and day of the week
Set time and day of the week by ▲ key (next hour by one push), ▼ key (next minute by one push) and SEL key (next day of week by one push).

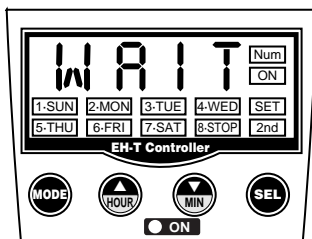

- (4) Push MODE key to confirm the setting and to return to WAIT mode.

6) Remarks

- (1) In case pump stopped by STOP signal, you can not operate pump even by manual operation mode.
- (2) For the setting of operation start time and operating time, do not set them extending into the next day.
- (3) The stroke rate at manual operation mode is the one at timer operation mode.

4. Maintenance

<i>4-1. Precautions when pump is disassembled</i>	<i>37</i>
<i>4-2. Diaphragm replacement</i>	<i>37</i>
<i>4-3. Valve replacement</i>	<i>38</i>
<i>4-4. Tubing</i>	<i>38</i>
<i>4-5. Consumable parts</i>	<i>39</i>
<i>4-6. Pump head disassembled view</i>	<i>40</i>

4-1. Precautions when pump is disassembled

Warning

- When the tube is removed from the pump or the pump is disassembled, be sure to release the pressure from the pump and tube. If the tube is removed or the pump is disassembled without releasing the pressure, the liquid will spout and dangerous.
- Pay attention not to touch the residual liquid when the pump is disassembled.

How to release the pressure:

1. Stop the pump operation.
2. Open the air vent port by turning counter clockwise an air vent adjusting screw by two turns.
3. Confirm the liquid comes out and the pressure is released.

Note: If the liquid does not come out, the pressure may not be released. In this case, operate the pump so that the liquid can come out and the pressure can be released.

Air vent valve is not built-in for EH-30, 35 and FC (PVDF material) type. For these models, install an air vent valve at discharge side to release the pressure.

For SH (stainless steel pump head) type, the pressure can not be released by air venting.

Install a valve at discharge side to release the pressure.

4-2. Diaphragm Replacement

Disconnect AC power to the pump and disconnect the suction tubing and discharge tubing. Remove the four head bolts with a 4 mm hex wrench. Turn the stroke length knob fully counter-clockwise to make diaphragm come to top position. Unscrew the diaphragm and remove its retainer (small disk behind the diaphragm). Install the new retainer and diaphragm on the shaft. Turn the diaphragm clockwise until it bottoms on the shaft. Replace the pump head and tighten the head bolts a torque of 2.16 N·m.

• Remarks

You may find some pieces of diaphragm spacers behind a diaphragm and retainer. These spacers are mounted for the purpose of positioning of diaphragm and all the shipped pumps do not have the spacers. Do not forget to mount them if they are originally mounted.

4-3. Valve Replacement

Remove the suction and discharge tubing. Remove the suction fitting, two valve cartridges, o-ring and gasket(s). Install the new o-ring, gasket(s) and valve cartridges. Be sure both valve seats are in the same orientation. Refer to figure below. Tighten the suction fitting. Similarly remove and replace the discharge valve cartridges, o-ring and gasket(s).

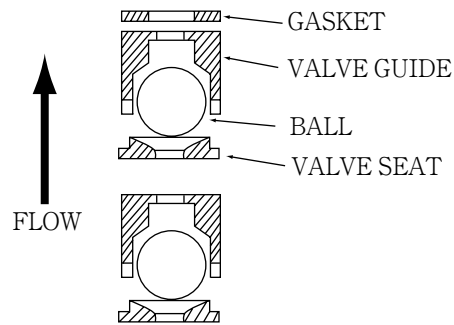



Valve Cartridge Orientation

4-4. Tubing

Check ends of tubing for splits, cracks, or thin spots. Examine the full length of tubing for damage due to chafing, abrasion, stress cracks, excessive temperature or exposure to ultraviolet light (direct sunlight or mercury vapor lamps). If any signs of deterioration exist, replace the entire length of tubing. It is a good idea to replace discharge tubing on a regular preventive maintenance schedule every 12 months.

4-5. Consumable Parts

Part		Qty.	Replacement Timing	Remarks
Valve set		2 sets	Approx. 8,000 hrs.	
Diaphragm		1		
O ring Valve gasket		(Note)		(Note) Number of parts applicable should be checked with reference to "Pump head disassembled view" on pages 40, 41.

- ▶ The durability of expendable parts depends on the pressure, temperature, and properties of the liquid handled. The value in the above table has been obtained from a continuous test run of the pump using pure water at room temperature. Take the value as a guideline for replacement.
- ▶ The illustration of valve set above is for VC, VH, PC and PH types. Refer to illustration on page 39 for the composition and shape of valve set of FC and SH types.

4-6. Pump head disassembled view

●EH-B10, B15, B20, C15, C20 Types

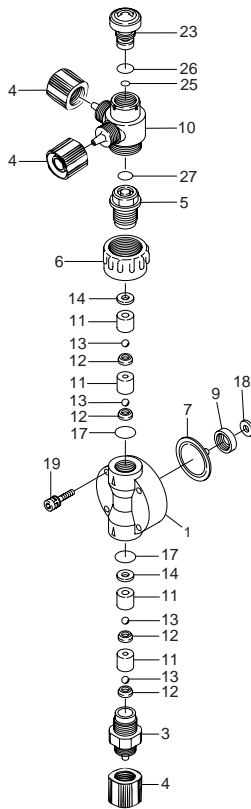

No.	Name	Quantity
1	Pump head	1
3	Fitting	1 (2)
4	Fitting nut	3 (2)
5	Air vent body B	1 (0)
6	Lock nut	1 (0)
7	Diaphragm	1
9	Retainer	1
10	Air vent body A	1 (0)
11	Valve guide	4
12	Valve seat	4
13	Valve ball	4
14	Valve gasket	2
17	O ring (S14)	2
18	Diaphragm spacer	1
19	Bolt with P/W, S/W	4
23	Adjusting screw	1
25	O ring (P4)	1
26	O ring (P10A)	1
27	O ring (P7)	1

●EH-B30, C30, C35 Types

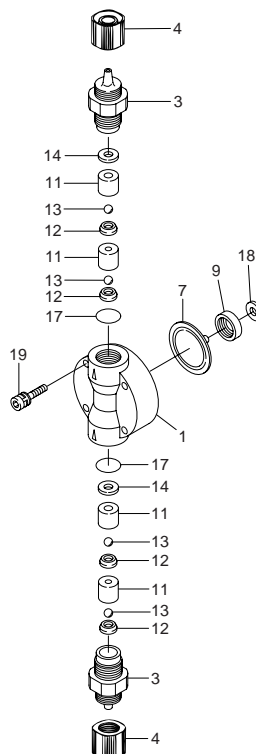

Note 1 : The quantity of the diaphragm spacers, which are for dimensional adjustment, depend on the type of pump.

2 : Quantity in parenthesis is for type EH-B30, C30, C35.

●EH-FC Type

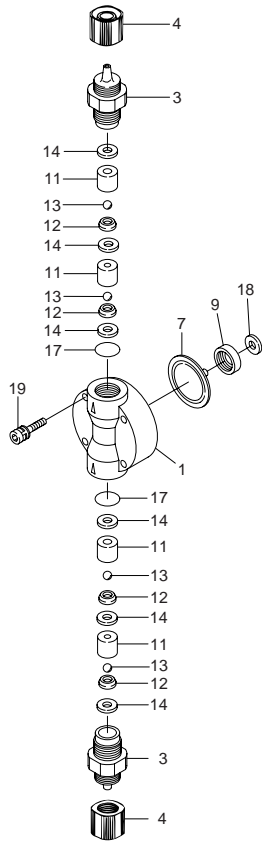

No.	Name	Quantity
1	Pump head	1
3	Fitting	2
4	Fitting nut	2
7	Diaphragm	1
9	Retainer	1
11	Valve guide	4
12	Valve seat	4
13	Valve ball	4
14	Valve gasket	6
17	Gasket	2
18	Diaphragm spacer	1
19	Bolt with P/W, S/W	4

Note 1 : The number of the diaphragm spacers, which are for dimensional adjustment, depend on the type of pump.

●EH-SH Type

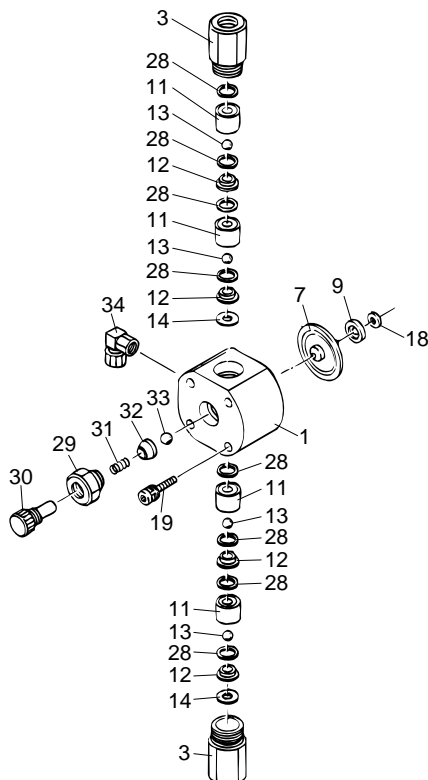

No.	Name	Quantity
1	Pump head	1
3	Fitting	2
7	Diaphragm	1
9	Retainer	1
11	Valve guide	4
12	Valve seat	4
13	Valve ball	4
14	Valve gasket B	2
18	Diaphragm spacer	1
19	Bolt with P/W, S/W	4
28	Valve gasket A	8
29	Seal nut	1
30	Adjusting bolt	1
31	Spring	1
32	Seal ring	1
33	Valve ball	1
34	Tube connector	1

5. Troubleshooting

5-1. Troubleshooting43

5-1. Troubleshooting

Caution



Before working on the pump, disconnect the power cord, depressurize the discharge tubing and drain or flush any residual liquid from the pump head and valves.

Problem	Possible Cause	Corrective Action
Pump does not start	Faulty wiring	Correct wiring
	Improper voltage	Connect to proper voltage source
	Electronic control unit is damaged	Replace control unit
Pump does not prime	Pump stroke length is too short	Operate pump with stroke length set at 100% until primed. Then set stroke length as needed to obtain desired output.
	Air in suction tubing	Reroute suction tubing to eliminate air trap
	Valve gasket is missing	Install valve gasket
	Valve set assembly direction is wrong	Reassemble valve set
	Pump is air locked	Prime pump per instructions
	Suction or discharge valve is clogged with foreign matter	Disassemble, inspect, clean
	Ball stuck to valve seat	Disassemble, inspect, clean
Output fluctuates	Suction or discharge valve is clogged with foreign matter	Disassemble, inspect, clean
	Air is trapped in pump	Prime pump per instructions
	Overfeeding	Install injection valve or back pressure valve
	Diaphragm is damaged	Replace diaphragm
	Worn check valves	Replace valve cartridges
Liquid leaks	Fitting or coupling nut is loose	Tighten
	Pump head is loose	Tighten pump head bolts Torque: 2.6 N·m
	Diaphragm is damaged	Replace diaphragm
	O-ring or valve gasket missing	Install o-ring or valve gasket



IWAKI CO.,LTD. 6-6 Kanda-Sudacho 2-chome Chiyoda-ku Tokyo 101-8558 Japan

TEL:(81)3 3254 2935 FAX:3 3252 8892(<http://www.iwakipumps.jp>)

()Country codes

U.S.A. : IWAKI WALCHEM Corporation	TEL : (1)508 429 1440	FAX : 508 429 1386	Germany : IWAKI EUROPE GmbH	TEL : (49)2154 9254 0	FAX : 2154 1028
Australia : IWAKI Pumps Australia Pty. Ltd.	TEL : (61)2 9899 2411	FAX : 2 9899 2421	Italy : IWAKI Italia S.R.L.	TEL : (39)02 990 3931	FAX : 02 990 42888
Singapore : IWAKI Singapore Pte. Ltd.	TEL : (65)763 2744	FAX : 763 2372	Denmark : IWAKI Pumper A/S	TEL : (45)48 24 2345	FAX : 48 24 2346
Indonesia : IWAKI Singapore (Indonesia Branch)	TEL : (62)21 690 6607	FAX : 21 690 6612	Sweden : IWAKI Sverige AB	TEL : (46)8 511 72900	FAX : 8 511 72922
Malaysia : IWAKIm Sdn. Bhd.	TEL : (60)3 7803 8807	FAX : 3 7803 4800	Finland : IWAKI Suomi Oy	TEL : (358)9 2742714	FAX : 9 2742715
Taiwan : IWAKI Pumps Taiwan Co., Ltd.	TEL : (886)2 8227 6900	FAX : 2 8227 6818	Norway : IWAKI Norge AS	TEL : (47)66 81 16 60	FAX : 66 81 16 61
Thailand : IWAKI (Thailand) Co.,Ltd.	TEL : (66)2 320 1303	FAX : 2 322 2477	France : IWAKI France S.A.	TEL : (33)1 69 63 33 70	FAX : 1 64 49 92 73
Hong Kong : IWAKI Pumps Co., Ltd.	TEL : (852)2 607 1168	FAX : 2 607 1000	U.K. : IWAKI PUMPS (UK) LTD.	TEL : (44)1743 231363	FAX : 1743 366507
China : IWAKI Pumps Co., Ltd. (Guangzhou office)	TEL : (86)20 8130 0605	FAX : 20 8130 0601	Switzerland : IWAKI (Schweiz) AG	TEL : (41)32 3235024	FAX : 32 3226084
China : IWAKI Pumps Co., Ltd. (Beijing office)	TEL : (86)10 6442 7713	FAX : 10 6442 7712	Austria : IWAKI (Austria) GmbH	TEL : (43)2236 33469	FAX : 2236 33469
China : IWAKI Pumps (Shanghai) Co., Ltd.	TEL : (86)21 6272 7502	FAX : 21 6272 6929	Holland : IWAKI Holland B.V.	TEL : (31)297 241121	FAX : 297 273902
Philippines : IWAKI Chemical Pumps Philippines, Inc.	TEL : (63)2 888 0245	FAX : 2 843 3096	Spain : IWAKI Iberica Pumps, S.A.	TEL : (34)943 630030	FAX : 943 628799
Korea : IWAKI Korea Co.,Ltd.	TEL : (82)2 3474 0523	FAX : 2 3474 0221	Belgium : IWAKI Belgium n.v.	TEL : (32)1430 7007	FAX : 1430 7008

T450-1 '02/06