

IWAKI

EWN-R
series

Electromagnetic metering pumps

Multi voltage, High-speed operation, Multifunctional controller
The high-end electromagnetic metering pump



The EWN-R is the diaphragm type electromagnetic metering pump with a built-in multifunctional digital controller. Our technology makes the high-speed operation of 360spm available.



Multi voltage, High-speed operation, Multifunctional controller The high-end electromagnetic metering pump



PVC type

GFRPP type

PVdF type

SUS type

The EWN-R is the diaphragm type electromagnetic metering pump with a built-in multifunctional digital controller. Our technology makes the high-speed operation of 360spm available. The built-in controller that handles both digital and analogue signals controls operation in various ways. PVC, GFRPP, PVdF or SUS316 pump head is selectable. Also, special pump types for particular purposes are lined up. The user-friendly EWN-R will meet a wide variety of demands for chemical feeding.



High resolution

The stroke rate can be set with 1spm increments in between 1 and 360spm. The stroke length adjustment further assists fine adjustment that the stroke rate adjustment can not reach. Contentious precise chemical feeding is now available.

Multi voltage

The use of the multi voltage circuit design allows the pump to work elsewhere in the world.

A wide variation

In addition to the standard type of PVC, GFRPP, PVdF or SUS316 pump head, B- or C-type drive unit and each diaphragm size, the high compression type for gaseous liquid transfer (sodium hypochlorite, etc), the high pressure type for power injection (boiler compounds, etc) and the high viscosity type for viscous liquid transfer (polymer liquid. etc) are available.

Built-in controller

The EWN-R has the mode of 1:1 operation, multiplier/divider programming control (digital signal) and proportional control (analogue signal) and can dedicate itself to a particular purpose by selecting a suitable mode. Also, the flow rate indication can be converted from spm to L/H or GPH.

Pump body

The use of the integrated controller reduces a sealing area, so that the water-/dust-proof design of IP65 is attained. Also, a plastic cover protects the control panel under an adverse environment.

Air vent valve

Rotating a standard air vent valve, the remained gas can be easily expelled from the pump head.



Multi hose connection

The use of a new hose stopper eliminates a twist in tube connection.



Technical data

Construction

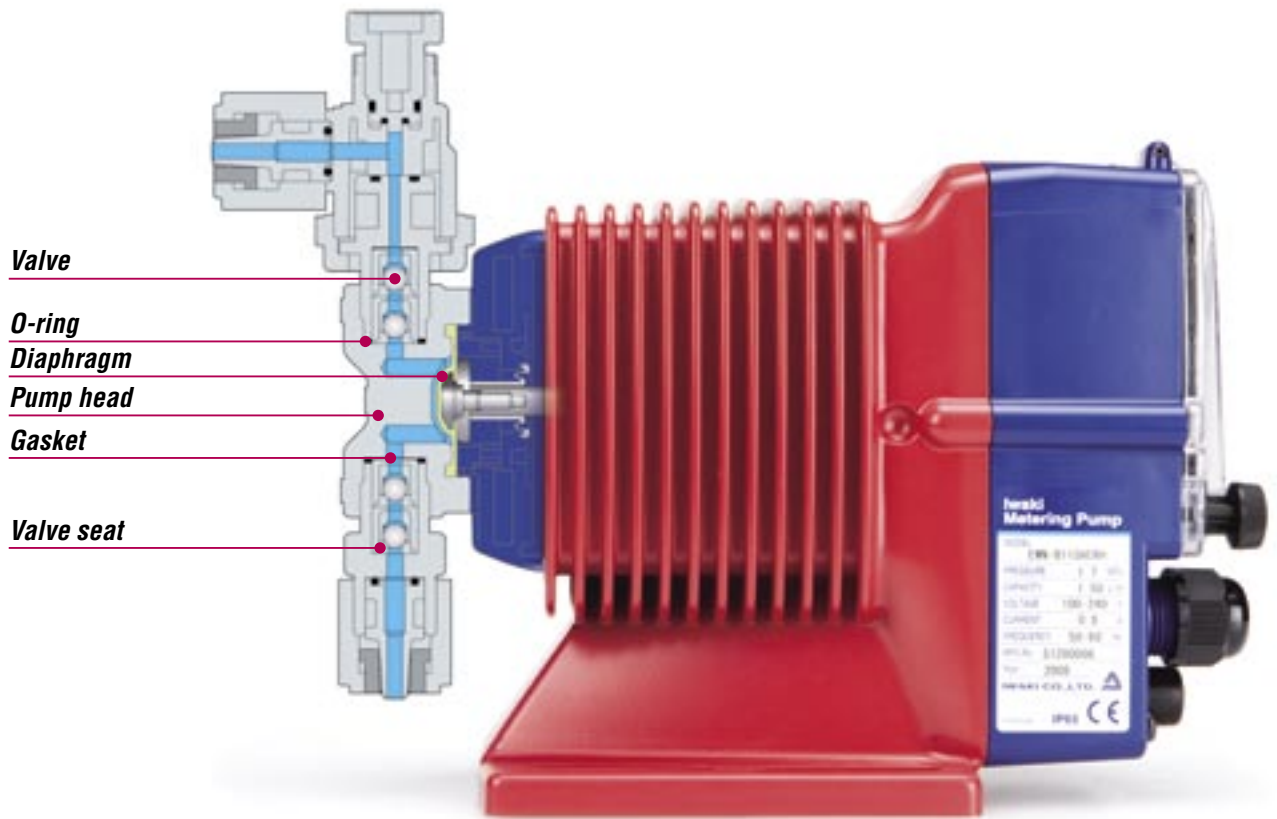

Valve

O-ring

Diaphragm

Pump head

Gasket

Valve seat

Wet-end materials

	Pump head	Valve	Valve seat	O-ring	Diaphragm	Gasket
VC	PVC	CE	FKM	FKM	PTFE+EPDM	PTFE
VH		HC	EPDM	EPDM		
PC	GFRPP	CE	FKM	FKM		
PH		HC	EPDM	EPDM		
FC	PVdF	CE	PCTFE	—		
TC			FKM	FKM		
SH	SUS316	HC	SUS316	—		

Pump identification

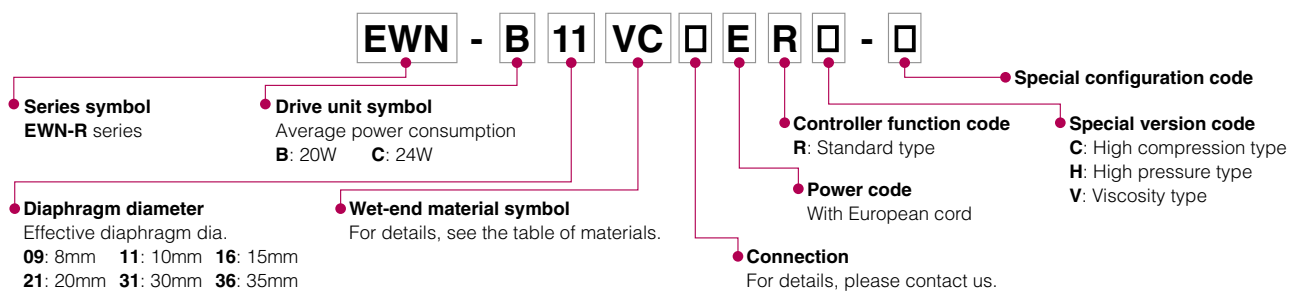

Specifications of pump

Model		B11	B16	B21	B31	C16	C21	C31	C36		
									VC/VH/PC/PH	FC/SH/TC	
Capacity	L/hr	2.3	3.9	6.0	12.0	4.8	7.8	16.2	25.2	24.6	
	mL/min	38	65	100	200	80	130	270	420	410	
	mL/shot	0.05 - 0.1	0.09 - 0.18	0.14 - 0.28	0.28 - 0.56	0.09 - 0.22	0.14 - 0.36	0.3 - 0.75	0.47 - 1.17	0.46 - 1.14	
Rated discharge pressure	MPa	1.0	0.7	0.4	0.2	1.0	0.7	0.35	0.2	0.2	
Max. pressure	MPa	(1.4)	(0.8)	(0.5)	—	(1.2)	(0.8)	—	—	—	
Stroke rate	% (spm)	0.1 - 100 (1-360)									
Stroke length range	% (mm)	50 - 100 (0.5 - 1.0)				40 - 100 (0.5 - 1.25)					
Current	A	0.8				1.2					
Average power consumption	W	20				24					

Note 1: Each discharge capacity shown above is at discharge pressure (stroke length 100%, stroke rate 100%) and increases as a discharge pressure reduces.

Note 2: The performance is based on pumping clean water at ambient temperature at rated voltage.

Note 3: Max pressure is not guaranteed under any discharge condition. Max pressure of PVC type is 1.2MPa.

Specifications of controller

Operational mode	MAN		0.1 - 100% stroke rate
	EXT	DIV (Dividing)	/1 - 9999
		MULT (Multiply)	x1 - 9999
		ANA.R (Analog, rigid)	4 - 20, 0 - 20, 20 - 4, 20 - 0 mA
	ANA.V (Analog, variable)	2 points 0.0 - 20.0 mA range 0.0 - 100% stroke rate	
Display	LCD	14seg 5digits	%, ml/m, L/H, GPH, STOP, PRIME, AUX etc
	LED	ON	Green Green lights when power is put and blinks synchronous with stroke.
		STOP	Orange/Red Orange lights when Pre-STOP is activated, and red when STOP is activated.
Keypad	5 Keys	Start/Stop, ▲(Up), ▼(Down), EXT, DISP	
Control function	STOP/Pre-Stop		Pump keeps running when Pre-STOP is activated. Pump stops when STOP is activated.
	Prime		Pump runs at max. stroke rate while up and down keys are pushed.
	Key lock		Key can be locked and unlocked.
	Calibration		Discharge capacity per shot is calculated automatically by operating and stopping pump at calibration mode to make flow rate indication possible.
	Buffer memory		ON or OFF is selectable. Max. 65535 stroke pulses are put in memory.
Input	Pulse		Non Voltage contact or open collector, Max. 200Hz
	Current		DC0 - 20mA (Input resistance 200Ω)
	Level sensor		No Voltage contact or open collector, 2- steps contact
	AUX		Pump runs at max.stroke rate while AUX signal is input.
Output	Photo-MOS relay AC/DC24V 0.1A		
	STOP, Synchronous with stroke		
	Synchronous with stroke is standard.		
Power Voltage	100 - 240 VAC 50/60Hz (90-264 VAC)		

* Note 1: If the max. stroke rate by calculation exceeds 100% stroke rate because of the relation between the setting and input signal when the pump is in EXT operation, the operation is fixed at Maximum stroke rate speed of manual operation.

* Note 2: By changing the setting, the pump can run when the contact signal come in.

* Note 3: The max. frequency of input pulse is 200 Hz. ON time of input pulse is 10 to 100 mS.

* Note 4: The max. chargeable voltage to a contact is 12V and current is 0.1mA. If a contact such as relay is used, the minimum application load should be 0.1mA or below.

The pump can be specialized for the need of a special chemical transfer.

High compression type

The optimum for sodium hypochlorite feeding

Increased compression ratio due to minimized dead volume in pump chamber. Suitable for injection of boiler chemicals such as hydrazine or so.

Construction

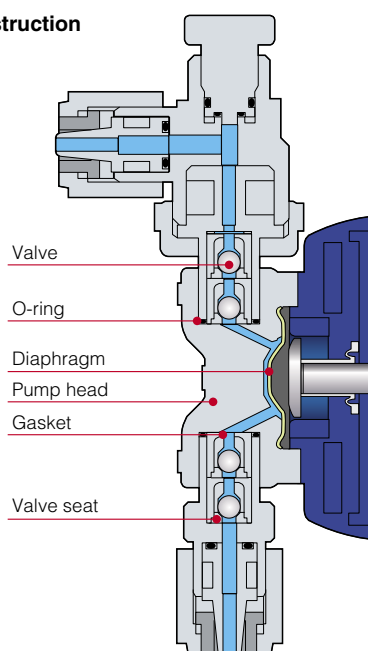

Wet-end material

Material code	VC	VH
Pump head	PVC	
Valve	CE	HC
Valve seat	FKM	EPDM
Gasket	PTFE	
O-ring	FKM	EPDM
Diaphragm	PTFE+EPDM	

High pressure type

Suitable for boiler chemical injection

- The high pressure type can handle the maximum discharge pressure of 1.5MPa.
- The 25 and 40mL/min (max. discharge pressure) types are available.
- Capable of boiler chemical injection to the discharge line of a water-supply pump as long as the discharge pressure is 1.5MPa or below

Construction

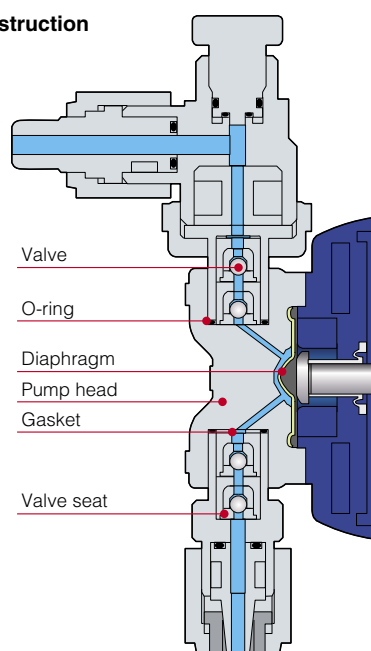

Wet-end material

Material code	PC	PH	SH
Pump head	GFRPP		
Valve	CE	HC	HC
Valve seat	FKM	EPDM	SUS316
Gasket	PTFE		
O-ring	FKM	EPDM	—
Diaphragm	PTFE+EPDM		

Viscosity type

Suitable for high-polymer coagulant injection

- The viscosity type can handle the maximum viscosity of 300mPa·s.
- Suitable for high-polymer coagulant injection in wastewater treatment

Construction

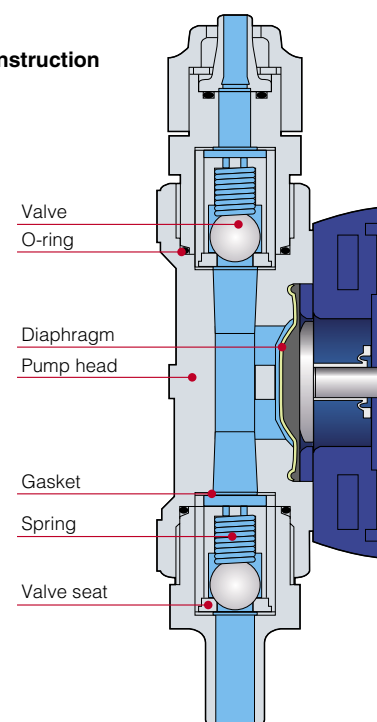

Wet-end material

Material code	PC
Pump head	GFRPP
Valve	CE
Valve seat	FKM
Spring	Hastelloy C276
Gasket	PTFE
O-ring	FKM
Diaphragm	PTFE+EPDM

Specifications

• High compression type

Model		B09	B11	B16	B21	C16	C21
Capacity	L/hr	0.7	1.4	2.4	3.8	3.2	4.7
	mL/min	12	23	40	63	54	78
	mL/shot	0.03 - 0.07	0.06 - 0.13	0.11 - 0.22	0.18 - 0.35	0.12 - 0.30	0.17 - 0.43
Discharge pressure	MPa	1.0	1.0	0.7	0.4	1.0	0.7
Stroke rate	% (spm)	0.1 - 100 (1-180)					
Stroke length range	% (mm)	50 - 100 (0.625 - 1.25)				40 - 100 (0.6 - 1.50)	
Current	A	0.8				1.2	
Average power consumption	W	20				24	

• High pressure type

Model		B11	C16
Capacity	L/hr	1.5	2.4
	mL/min	25	40
	mL/shot	0.05 - 0.1	0.07 - 0.17
Discharge pressure	MPa	1.7	1.7
Stroke rate	% (spm)	0.1 - 100 (1-240)	
Stroke length range	% (mm)	50 - 100 (0.5 - 1.0)	40 - 100 (0.5 - 1.25)
Current	A	0.8	1.2
Average power consumption	W	20	24

• Viscosity type

Model		C31
Capacity	L/hr	7.4
	mL/min	124
	mL/shot	0.21 - 0.52
Discharge pressure	MPa	0.35
Stroke rate	% (spm)	0.1 - 100 (1-240)
Stroke length range	% (mm)	40 - 100 (0.5 - 1.25)
Current	A	1.2
Average power consumption	W	24

Note 1: Each discharge capacity shown above is at discharge pressure (stroke length 100%, stroke rate 100%) and increases as a discharge pressure reduces.
 Note 2: The performance is based on pumping clean water at ambient temperature at rated voltage.

Optional accessories

Accessories

Check valve CAN / CBN / CS

This has the function of a non-return valve and prevents siphon and overfeed.

CAN: Available in PVC and CFRPP



CBN: In-line type to be connected in the middle of a hose; made of PVC.



CS: Made of stainless steel for SH type.



Specifications

Model	Connection		Set pressure MPa	Material			Applicable pump
	Inlet mm	Outlet mm		Body	Spring	O-ring	
CA-1VC (CA-1V)	4x6, 5x8 6x8, 6x12	R3/8 and R1/2	0.17±0.04	PVC (CFRPP)	Hastelloy C276	FKM	EWN-B09, 11, 16, 21, C16, 21
CA-1VE (1E)			0.17±0.04			EPDM	
CA-2VC (2V) CA-2VE (2E)	9x12		0.17±0.04			FKM	
CA-2VCL (2VL) CA-2VEL (2EL)	9x12	R3/8 and R1/2	0.05±0.03	PVC	Hastelloy C276	FKM	EWN-B31, C36
CB-1VC CB-1VE	4x6		4x6			0.17±0.04	
CS-1S CS-1SL	Rc1/4	Rc1/4	0.2±0.03 0.05±0.03	SUS316	Hastelloy C276	-	EWN-B11, 16, 21, C16, 21, 31 EWN-B31, C36

Siphon preventing valve BVC

Made of PVC or GFRPP consisting of non-metallic parts.



Specifications

Model	Connection		Set pressure MPa	Material		Applicable pump
	Inlet mm	Outlet		Body	O-ring	
Note BVC-1 □□	4x6 6x8 9x12	R3/8 or R1/2	0.2 or 0.05	PVC	FKM or EPDM	All models

Note: Different models are available. Please contact for particulars.

Multi-function valve MFV

This valve has the multi-function of air vent, pressure release inside pipe and back pressure valve.



Specifications

Model	Tube connection	Set pressure	Material	Applicable pump
MFV-SVC	4x6mm 5x8mm 6x8mm 6x12mm	0.2 ± 0.13 MPa	PVC / FKM / PTFE	EWN-B09, 11, 16, 21, C16, 21
MFV-SVH			PVC / EPDM / PTFE	
MFV-SPC			GFRPP / FKM / PTFE	
MFV-SPH			GFRPP / EPDM / PTFE	

Foot valve FS / FSP / FSTC

This foot valve with a strainer is made of PVC or GFRPP.



Specifications

Model	Tube connection	Material	Applicable pump
FSV	4x6mm	PVC / FKM / Alumina ceramic	All models
FSE	5x8mm	PVC / EPDM / HastelloyC276	
FSPV	6x8mm	GFRPP / FKM / Alumina ceramic	
FSPE	6x12mm	GFRPP / EPDM / HastelloyC276	
FSTC	9x12mm	GFRPP / EPDM / HastelloyC276	
	10x12mm	Pvdf / FKM / Alumina ceramic	

Chemical tank EXDT

This is a polyethylene round tank.



Capacity: 35, 60, 100, 200 or 300L

Priming set PS

Made of PVC furnished with level sensor(s) and foot valve.



Specifications

Model	Level switch	Connection mm	Length mm
PS-1	Single	4x6, 5x8, 6x8, 6x12, 9x12	520, 650, 810, 1000, 1350
PS-2	Double		520, 720, 810, 1000, 1350

Pulse oscillating flow meter



Specifications

Connection	Max. capacity	Range of pulse
3/4"	5m ³ /h	1xOutput pulse against 0.25L
		1xOutput pulse against 0.50L
		1xOutput pulse against 1.00L
1"	12m ³ /h	1xOutput pulse against 0.25L
		1xOutput pulse against 0.50L
		1xOutput pulse against 1.00L
1 1/2"	20m ³ /h	1xOutput pulse against 0.25L
		1xOutput pulse against 0.50L
		1xOutput pulse against 1.00L

Dimensions in mm

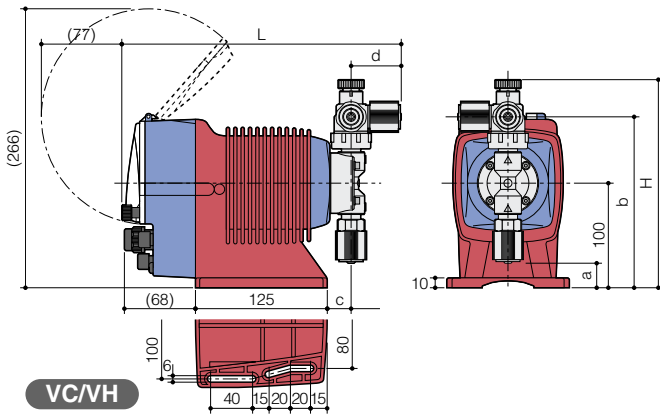

VC/VH

Model	H	L	a	b	c	d
EWN-11, 16, 21	(199)	(265)	(24)	(164)	(23)	(47)
EWN-31	(212)	(267)	(6)	(177)	(25)	(48)
EWN-36	(211)	(267)	(7)	(176)	(24)	(48)

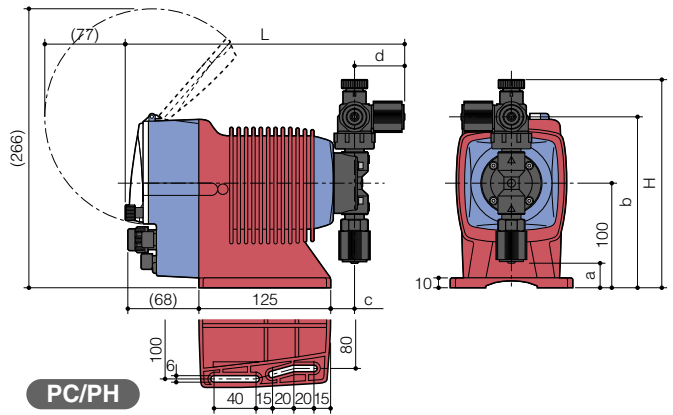

PC/PH

Model	H	L	a	b	c	d
EWN-11, 16, 21	(199)	(265)	(24)	(164)	(23)	(47)
EWN-31	(212)	(267)	(6)	(177)	(25)	(48)
EWN-36	(211)	(267)	(7)	(176)	(24)	(48)

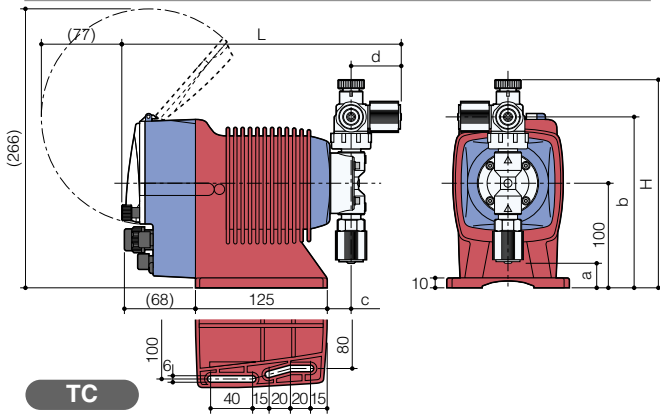

TC

Model	H	L	a	b	c	d
EWN-11, 16, 21	(198)	(265)	(25)	(163)	(23)	(47)
EWN-31	(211)	(267)	(7)	(176)	(25)	(48)
EWN-36	(211)	(268)	(6)	(176)	(24)	(49)

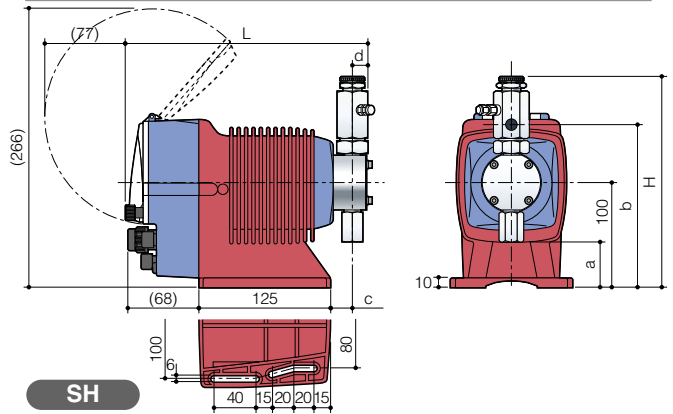

SH

Model	H	L	a	b	c	d
EWN-11, 16, 21	(201)	(232)	(44)	(155)	(22)	(15)
EWN-31	(213)	(233)	(34)	(167)	(23)	(15)
EWN-36	(216)	(233)	(32)	(170)	(23)	(15)

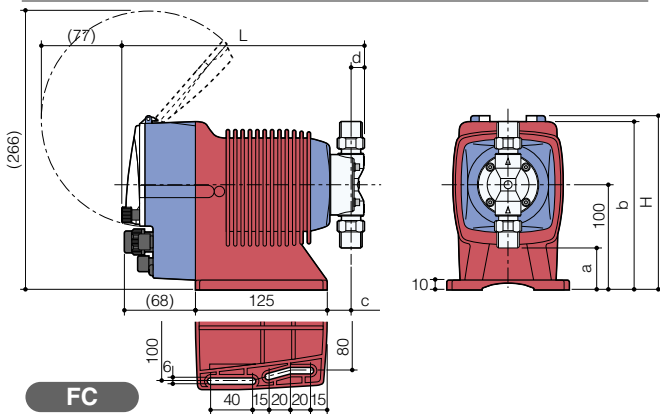

FC

Model	H	L	a	b	c	d
EWN-16, 21	(166)	(231)	(40)	(160)	(23)	(13)
EWN-31	(177)	(236)	(23)	-	(25)	(16)
EWN-36	(177)	(235)	(23)	-	(24)	(16)

www.iwakipumps.jp

IWAKI CO.,LTD. 6-6 Kanda-Sudacho 2-chome Chiyoda-ku Tokyo 101-8558 Japan TEL : (81)3 3254 2935 FAX : 3 3252 8892

EUROPE / U.S.A.

European office :	IWAKI Europe GmbH	TEL: (49)2154 9254 0	FAX: 2154 9254 48
Austria :	IWAKI (Austria) GmbH	TEL: (41)26 674 93 00	FAX: 26 674 93 02
Belgium :	IWAKI Belgium N.V.	TEL: (32)13 67 02 00	FAX: 13 67 20 30
Denmark :	IWAKI Nordic A/S	TEL: (45)48 24 2345	FAX: 48 24 2346
Finland :	IWAKI Suomi Oy	TEL: (358)9 27458 10	FAX: 9 27427 15
France :	IWAKI France S.A.	TEL: (33)1 69 63 33 70	FAX: 1 64 49 92 73
Germany :	IWAKI Europe GmbH	TEL: (49)2154 9254 50	FAX: 2154 9254 55
Holland :	IWAKI Holland B.V.	TEL: (31)297 241121	FAX: 297 273902
Italy :	IWAKI Italia S.R.L.	TEL: (39)02 990 3931	FAX: 02 990 42688
Norway :	IWAKI Norge AS	TEL: (47)66 81 16 60	FAX: 66 81 16 61
Spain :	IWAKI Iberica Pumps, S.A.	TEL: (34)943 630030	FAX: 943 628799
Sweden :	IWAKI Sverige AB	TEL: (46)8 511 72900	FAX: 8 511 72922
Switzerland :	IWAKI (Schweiz) AG	TEL: (41)26 674 93 00	FAX: 26 674 93 02
U.K. :	IWAKI Pumps (UK) Ltd.	TEL: (44)1743 231363	FAX: 1743 366507
U.S.A. :	IWAKI America Inc.	TEL: (1)508 429 1440	FAX: 508 429 1386

ASIA / OCEANIA

Australia :	IWAKI Pumps Australia Pty Ltd.	TEL: (61)2 9899 2411	FAX: 2 9899 2421
China :			
Hong Kong :	IWAKI Pumps Co., Ltd.	TEL: (852)2607 1168	FAX: 2607 1000
Shanghai :	IWAKI Pumps (Shanghai) Co., Ltd.	TEL: (86)21 6272 7502	FAX: 21 6272 6929
Guangzhou :	GFTZ IWAKI Engineering & Trading Co., Ltd.	TEL: (86)20 8435 0603	FAX: 20 8435 9181
Beijing :	GFTZ IWAKI Engineering & Trading Co., Ltd. (Beijing office)	TEL: (86)10 6442 7713	FAX: 10 6442 7712
Korea :	IWAKI Korea Co., Ltd.	TEL: (82)2 2630 4800	FAX: 2 2630 4801
Malaysia :	IWAKI M Sdn. Bhd.	TEL: (60)3 7803 8807	FAX: 3 7803 4800
Singapore :	IWAKI Singapore Pte Ltd.	TEL: (65)6316 2028	FAX: 6316 3221
Indonesia :	IWAKI Singapore (Indonesia Branch)	TEL: (62)21 6906606	FAX: 21 6906612
Taiwan :	IWAKI Pumps Taiwan Co., Ltd.	TEL: (86)2 8227 6900	FAX: 2 8227 6818
Thailand :	IWAKI (Thailand) Co., Ltd.	TEL: (66)2 322 2471	FAX: 2 322 2477
Vietnam :	IWAKI Pumps Vietnam Co., Ltd.	TEL: (84)613 933456	FAX: 613 933399

()Country codes

Caution for safety use: Before use of pump, read instruction manual carefully to use the product correctly.

Actual pumps may differ from the photos. Specifications and dimensions are subject to change without prior notice. For further details please contact us.

Legal attention related to export.

Our products and/or parts of products fall in the category of goods contained in the Export Trade Control Order Attachment List 1 of Japanese export control regulations, which includes complementary export control items. Please be reminded that export license, which is issued by the Ministry of Economy, Trade, and Industry in Japan could be required when products are exported from Japan.

