

IWAKI

Electromagnetic Metering Pump

EW Series

Instruction Manual

 Read this manual before use of product

Thank you for having selected Iwaki's EW Series electromagnetic metering pump. This instruction manual, which is divided into 5 sections, namely "Safety Section," "Outline Section," "Installation Section," "Operation Section" and "Maintenance Section," deals with the correct handling and operation procedures for the pump. You are requested to read this manual prior to using the pump, to ensure safe and long operation.

Contents



IMPORTANT INSTRUCTION	1
Safety Section	2
 OUTLINE OF PRODUCT	 5
1. Unpacking and Inspection	6
2. Operation Principle	6
3. Identification Codes	7
4. Specifications	8
5. External Dimensions	11
6. Main Parts and Label	15
 INSTALLATION	 16
1. Before Use	17
2. Notes on Operation	17
3. Installation, Piping, and Wiring	20
 PUMP OPERATION	 26
1. Bleeding	27
2. Adjustment of flow rate	29
3. Operation	31
 MAINTENANCE	 35
1. Causes of Trouble and Troubleshooting	36
2. Maintenance and Inspection	37
3. Disassembly and Reassembly	38
4. Accessories	42
5. Names of Parts and Structure.....	43

This instruction manual should be kept on hand by the end user for quick reference. It is recommended that each user, after reading the instruction manual thoroughly, place it in a position close to the pump system and where it may be easily accessed by any user at any time whenever necessary.

Important Instruction

For the Safe and Correct Handling of the Pump

- Read the "Safety Instructions" sections carefully to prevent accidents involving your customers or other personnel and to avoid damage or loss of other assets. Always follow the instructions and advice found in these sections.
- Observe and abide by the instructions described in this manual. These instructions are very important for protecting pump users from dangerous conditions and situations related with the use of the pump system.
- The symbols relate to the following meanings described below:

 Warning	Nonobservance or misapplication of the contents of the "Warning" section could lead to a serious accident, including death or injury.
 Caution	Nonobservance or misapplication of the contents of the "Caution" section could lead to serious physical injury to the user or serious damage to the product.

Types of Symbols



Indicates that "Warning" or "Caution" must be exercised. Inside this triangle, a concrete and practical image provided as a warning or caution message is depicted.



Indicates a prohibited action or procedure. Inside or near this circle, a concrete and practical image of the activity to be avoided is depicted.



Indicates an important action or procedure which must be performed or carried out without fail. Failure to follow the instructions herein can lead to malfunction or damage to the pump.

Safety Section

WARNING

- **Turn off the power supply**

Working without disconnecting the power supply may cause an electrical shock. Before engaging upon any working procedures involving the pump, make sure to turn the power supply switch off and to stop the pump and other related devices.



- **Terminate operation**

When you detect or become aware of a dangerous sign or abnormal condition during operation, terminate the operation immediately and start it from the beginning again.



- **For specified application only**

The use of a pump in any application other than those clearly specified may result in injury or damage to the pump. Use the pump strictly in accordance with the pump specifications and application range.



- **No remodeling**

Never remodel a pump. Otherwise, a serious accident may result. Iwaki will not be responsible for any accident or damage of any kind which is caused by the user remodeling the pump without first obtaining permission or instructions from Iwaki.



- **Wear protectors**

If you touch or come in contact with any type of hazardous chemical liquid, including but not limited to chemicals, you may experience a serious injury. Wear protective gear (protective mask, gloves, etc.) during the pump operation.



- **Operating site must be free of water and humidity**

The pump is not designed to be water-proof or dust-proof. The use of the pump in places where water splashes or humidity is high may result in an electrical shock or short circuit.



CAUTION

- **Qualified operators only**

The pump operator and pump operation supervisor must not allow any operators who have little or no knowledge of the pump to run operate the pump. Pump operators must have a sound knowledge of the pump and its operation.



- **Specified power only**

Do not operate the pump on voltage which is not specified on the nameplate. Failure to do so may result in damage or fire. Only the specified power level is to be applied.



Safety Section

CAUTION

- **Do not run the pump dry**

Do not run the pump dry (without liquid inside the pump). Heat generated as a result of abrasion between elements inside the pump during operation without liquid may damage the inside of the pump.



Prohibited

- **Do not wet or dampen**

If an electric part or wiring gets wet with the liquid spilled over accidentally, a fire or electrical shock may be caused. Install the system in a place free from liquid spillage or leakage.



Do not wet or dampen

- **Ventilate**

Poisoning may result during an operation which involves toxic or odorous liquid. Ventilate the operating site sufficiently.



Caution

- **Spill-out accident**

Protective measures should be taken against any accidental spill-out or leakage of the operating liquid as a result of unexpected damage on the pump or the related piping.



Caution

- **Damaged pump**

Never operate a damaged pump. A damaged pump may cause leakage or electrical shock.



Prohibited

- **Do not damage power cable**

Do not scratch, damage, process, or pull the power cable forcibly. An extra load onto the cable, such as heating the cable or placing something heavy on the cable, may damage the cable and finally cause a fire or an electrical shock.



Caution

- **Arrange grounding**

Do not operate the pump without connecting the grounding wire. Otherwise, an electrical shock may result. Make sure the grounding wire is connected with the grounding terminal.



Grounding

- **Install an earth leakage breaker**

The operation of a pump without using an earth leakage breaker may cause an electrical shock. Please install an optional leakage breaker in the system.



Electrical Shock

- **Handling of power cable**

Use of a defective or damaged power cable may result in a fire or electrical shock. Handle the power cable carefully.



Electrical Shock

Safety Section

CAUTION

- **Follow the instruction manual**

Replace the consumable parts by following the descriptions in the instruction manual. Do not disassemble any part of the pump if the disassembling procedure for the part in question is not included in the instruction manual.



- **Limited operating site and storage**

Do not install or store the pump in the following places:

- * Places where a flammable gas or material is used or stored.
- * Places where the ambient temperature is extremely high (40°C or higher) or extremely low (0°C or lower).



Prohibited

- **Disposal of used pump**

Disposal of used or damaged pumps must be done in accordance with the relevant local laws and regulations. (Consult a licensed industrial waste products disposing company.)



OUTLINE OF PRODUCT

<i>1. Unpacking and Inspection.....</i>	<i>6</i>
<i>2. Operation Principle</i>	<i>6</i>
<i>3. Identification Codes</i>	<i>7</i>
<i>4. Specifications.....</i>	<i>8</i>
<i>5. External Dimensions</i>	<i>11</i>
<i>6. Main Parts and Label</i>	<i>15</i>

1. Unpacking and Inspection

Iwaki Metering Pump		FREQUENCY Hz	
MODEL		MFG.No.	
MAX.PRESS.	MPa	Year :	
CAPACITY	L/H	IWAKI CO.,LTD.	
STROKE RATE	spm	IP67 CE	
VOLTAGE ~	V	1P421783	
CURRENT	A		

After unpacking the pump, check the following points to ascertain that the product is exactly as you ordered. If you find anything wrong, please get in touch with your dealer.

[1] Do the model, discharge pressure, voltage, etc., shown on the nameplate represent what you ordered?

[2] Has the pump been damaged in transit? Are the bolts and nuts loose?

2. Operation Principle

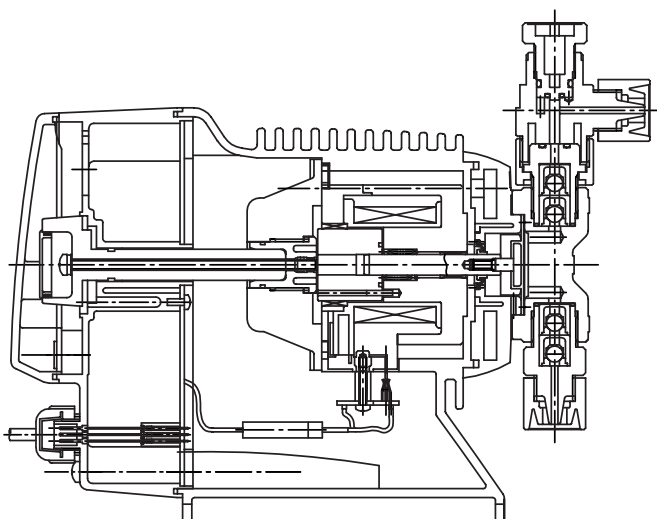

The Iwaki EW series electromagnetic pump is a diaphragm metering pump of the 'linear electromagnetic drive system', which means electromagnetic force drives the diaphragm directly. It consists of a pump unit, a drive unit and a control unit. Reciprocating movement is caused by the electromagnetic force produced by the pulse current sent from the control unit, and the force of a spring. The reciprocating movement is transmitted to the diaphragm directly connected to a plunger, to change the capacity of the pump chamber. The changed capacity and the functioning of the valves in the pump unit drive the pump.

3. Identification Codes

■ Pump Identification

EW - F 10 VC - 20E P F 2

① ② ③ ④ ⑤ ⑥ ⑦ ⑧ ⑨

① Series code

② Drive unit type

Code	Power consumption	Stroke length
B	10 W	1 mm
F	16 W	1.25 mm
G	24 W	1.5 mm

③ Diaphragm diameter

Code	Effective diameter [mm]
08	8
10	10
15	15
20	20
30	30
35	35
45	45

④ Wet end material

Code	Pump head	Valve	Valve seat	Diaphragm	Gasket
VC	PVC	CE	FKM	PTFE/EPDM	PTFE
VH		HC	EPDM		
PC	GFRPP	CE	FKM		
PH		HC	EPDM		
SH	SUS316	HC	SUS316		
TC	PVDF	CE	FKM		

Material PVC : Transparent polyvinyl chloride
 GFRPP: Glassfiber reinforced polypropylene
 CE: Alumina Ceramic
 HC: Hastelloy C 276
 FKM: Fluoroelastomer
 EPDM: Ethylene propylene diene methylene
 PTFE: Polytetrafluoroethylene

⑤ Power source voltage

Code	Power source	Frequency (Hz)
20E	AC220/230/240V	50/60

⑥ Power cord

Code	Cord end
No code	Crimp-style terminals
P	With plug

⑦ Controller code

F : F type controller

⑧ Connection hose

Code	Hose diameter
2	$\phi 4 \times \phi 6$
3	$\phi 6 \times \phi 8$
5	$\phi 9 \times \phi 12$
6	$\phi 10 \times \phi 12$
9	Rc1/4" (Female)

⑨ Special version code

4. Specifications

■ Pump specifications

<VC, VH, PC, PH>

Model	Max. discharge capacity L/H (ml/min)	Discharge capacity/shot ml	Max. discharge pressure MPa	Stroke rate spm	Stroke length mm
EW-B08	0.6 (10)	0.056	1.0	1 ~ 180	1.0
EW-F10	1.5 (26)	0.142	1.0	1 ~ 180	1.25
EW-F15	2.5 (42)	0.233	1.0	1 ~ 180	
EW-F20	3.6 (60)	0.333	0.7	1 ~ 180	
EW-F30	9.0 (150)	0.833	0.3	1 ~ 180	
EW-G20	4.7 (78)	0.433	1.0	1 ~ 180	1.50
EW-G30	9.9 (165)	0.917	0.6	1 ~ 180	
EW-G35	15.1 (252)	1.400	0.4	1 ~ 180	
EW-G45	24.0 (400)	2.200	0.2	1 ~ 180	

<SH, TC>

Model	Max. discharge capacity L/H (ml/min)	Discharge capacity/shot ml	Max. discharge pressure MPa	Stroke rate spm	Stroke length mm
EW-B08	0.6 (10)	0.056	1.0	1 ~ 180	1.0
EW-F10	1.5 (26)	0.142	1.0	1 ~ 180	1.25
EW-F15	2.4 (40)	0.233	1.0	1 ~ 180	
EW-G20	4.7 (78)	0.433	1.0	1 ~ 180	1.50
EW-G30	9.9 (165)	0.917	0.6	1 ~ 180	
EW-G35	13.8 (230)	1.400	0.4	1 ~ 180	
EW-G45	SH : 22.8 (380), TC : 24.0 (400)	SH : 2.110, TC : 2.200	0.2	1 ~ 180	

Note 1: The table shows the results of tests with clear water at the rated voltage and normal temperature.

Note 2: The maximum flow rate is the figures at the max. discharge pressure, max. stroke frequency and at full stroke length. At a lower pressure, the discharge flow is larger than shown in the table.

Note 3: Liquid temperature: -10~60°C (VC, VH : -10~40°C)

Note 4: Permissible voltage fluctuation: Within ± 10% of rating

Note 5: Self priming height is 1m in the above mentioned operating and liquid conditions.
(0.5m for type B08)

Note 6: Max. discharge pressure when pumping liquid at temperature 0 to -10°C is limited to 70% of rated max. discharge pressure shown on above table.

■ Controller specifications

Function	Function	MANUAL (Manual operating)
		EXT: 1 point (Operation by external signal)
		STOP: 2 points (Stop by external signal)
	Change	Three membrane keys of UP, DOWN and START/STOP
Control function	Setting	<input type="radio"/> MANUAL Stroke rate: 1~180 spm <input type="radio"/> EXT Digital input operation : 1 : 1 (No pulse memory, Max. spm at overflow)
	Stop	LED is lit when pre-stop contact input is activated. Pump stops when stop contact input is activated.
	Max. SPM	180spm (Standard)
Display	Data	LCD 4 digits (Running condition, Set values etc.)
	Pump operation	ON LED (lit green synchronous with stroke) STOP LED (lit orange when pre-stop signal comes in and red when stop signal comes in.)
Input	Pulse	Voltage free contact
	Stop/Pre-Stop	Level sensor : Voltage free contact (Either normal open or normal close contact can be selected.)
	Voltage	Max 24V DC
Output	Stop	PNP transistor not isolated (Impedance 330 Ohm)
	Synchronous with stroke	PNP transistor not isolated (Impedance 330 Ohm)
Connection	External connection	DIN connector

■ Environmental specifications

- (1) Outdoor installation
- (2) Ambient temperature : 0 ~ 40°C
- (3) Ambient humidity : 35% ~ 85% RH (Condensation should not be generated in the controller.)
- (4) Storage temperature : -10 ~ 50°C

■ Sound level

The sound level of the each type of the pump is 70 dB (A scale) or less at a distance of one meter

5. External Dimensions

● EW-B08 Type (VC, VH, PC, PH, TC)

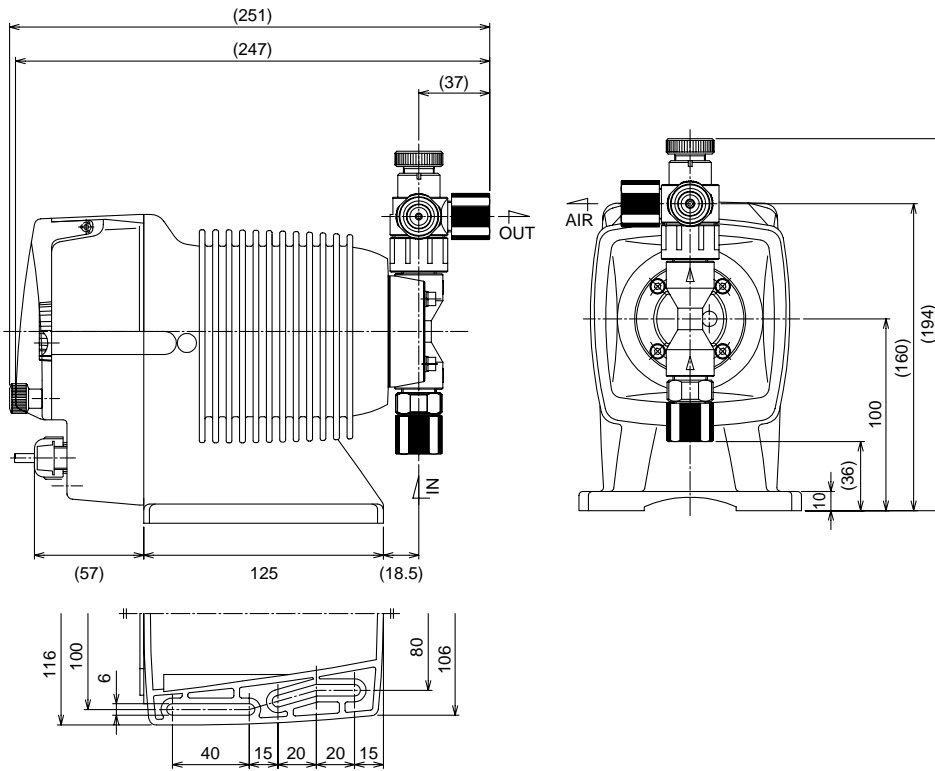

● EW-F10,F15, F20 G20 Types (VC, VH, PC, PH, TC)

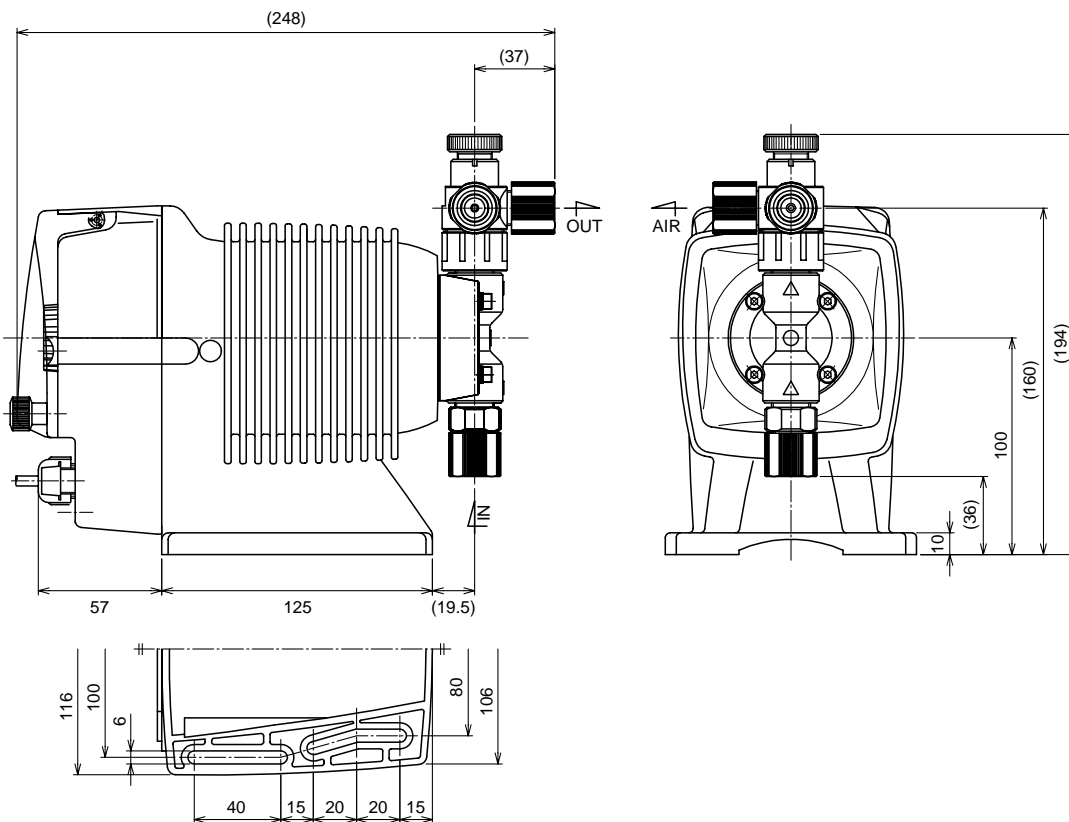

● EW-F30, G30 Types (VC, VH, PC, PH, TC)

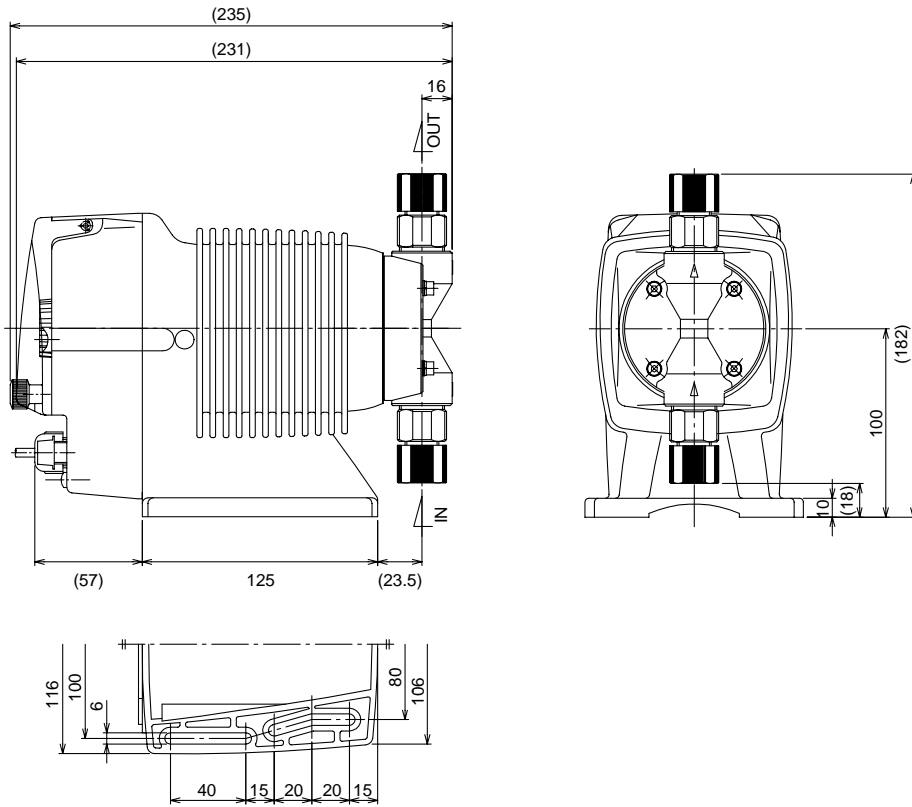

● EW-G35 Type (VC, VH, PC, PH, TC)

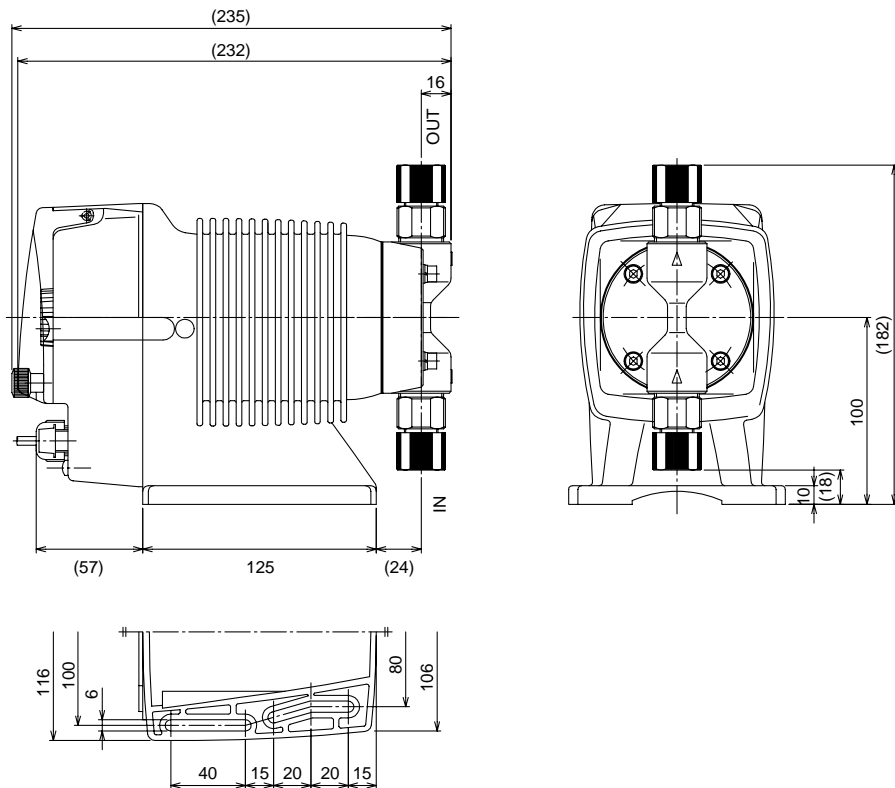

● EW-G45 Type (VC, VH, PC, PH, TC)

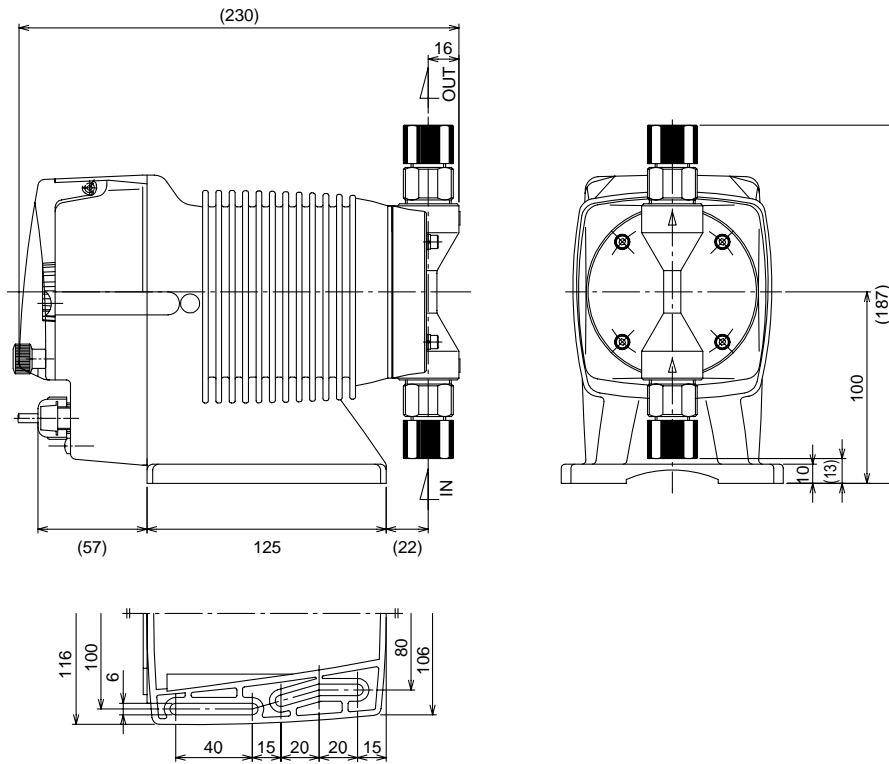

● EW-B08, F10, F15, G20 Types (SH)

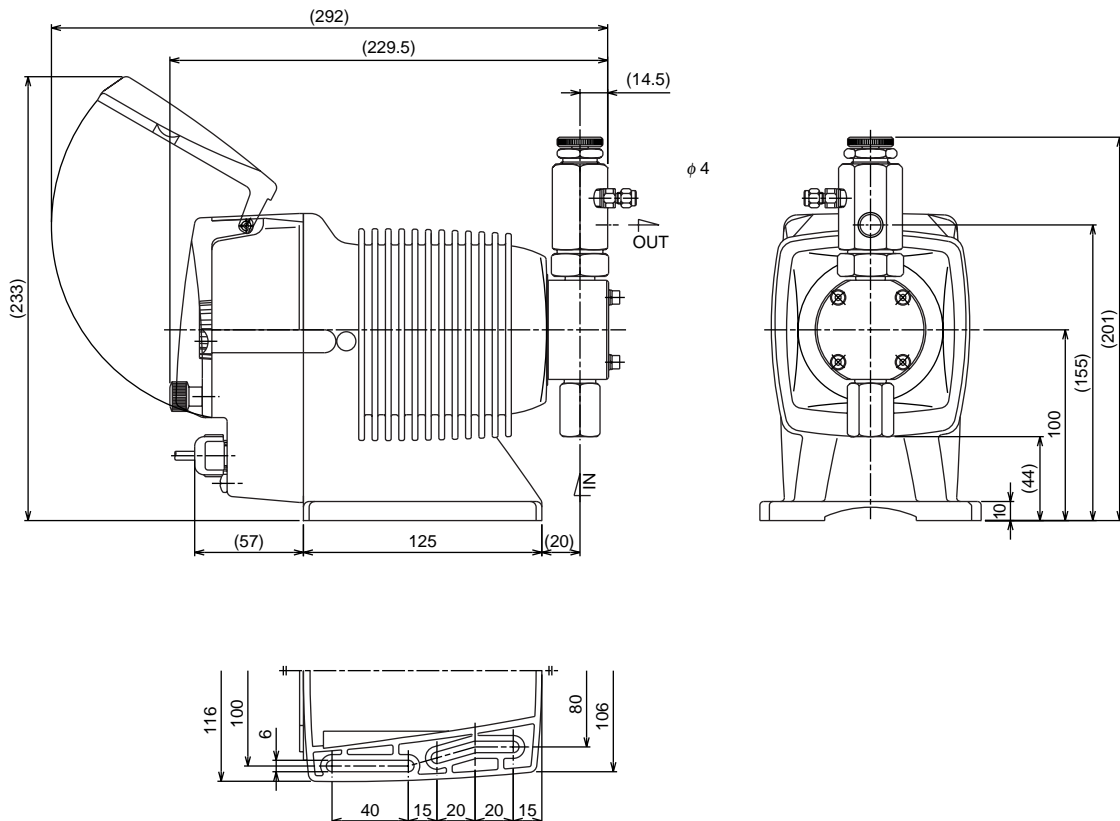

● EW-G30, G35 Types (SH)

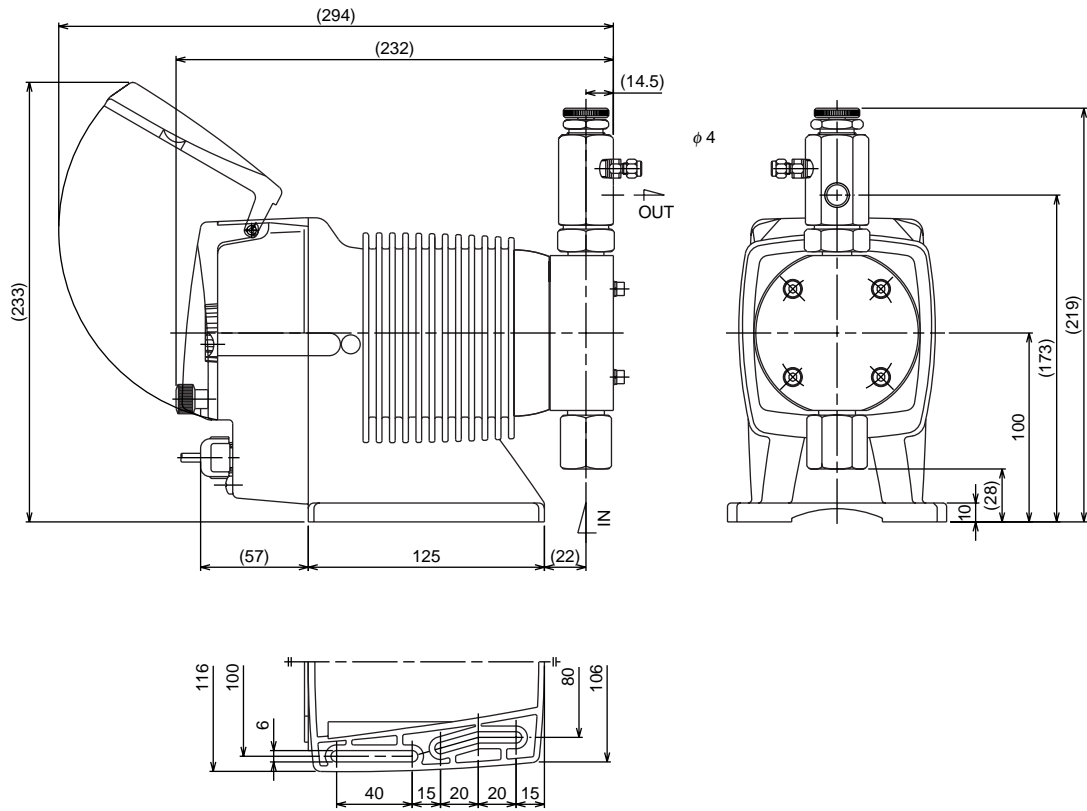

● EW-G45 Type (SH)

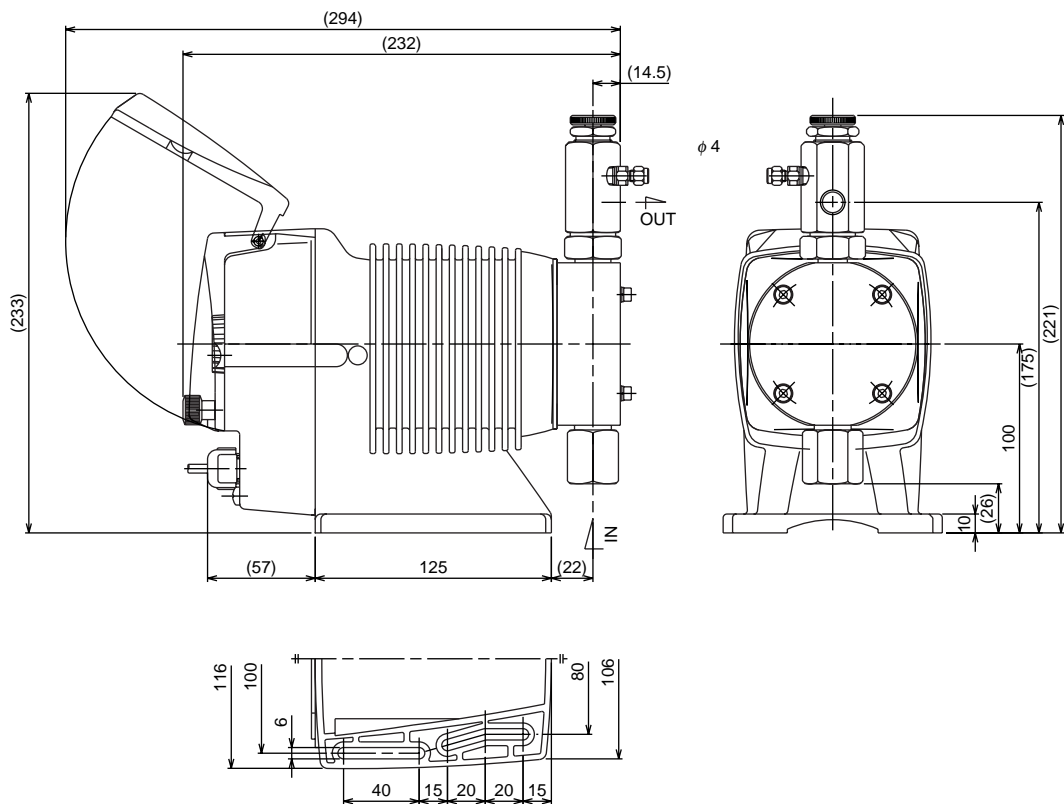

6. Main Parts and Label

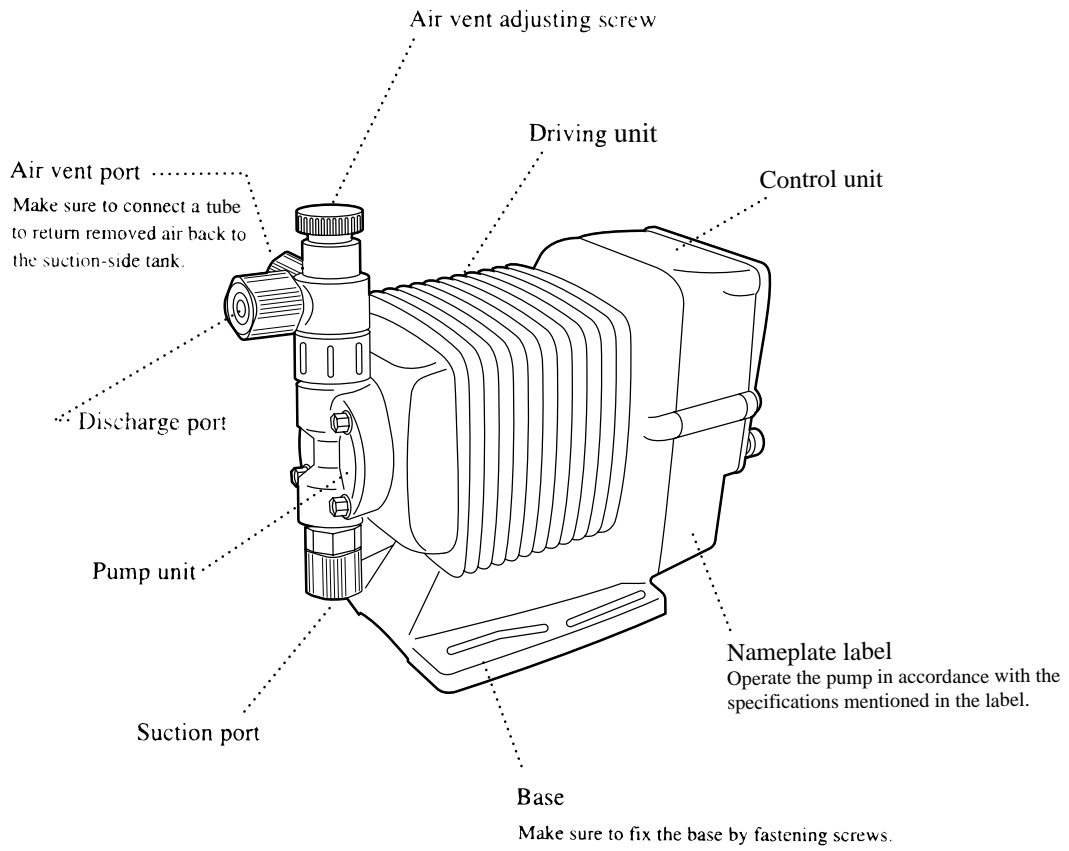

INSTALLATION

<i>1. Before Use</i>	<i>17</i>
<i>2. Notes on Operation</i>	<i>17</i>
<i>3. Installation, Piping, and Wiring</i>	<i>20</i>

1. Before Use

“Strictly observe the following points.”

Operators and maintenance service staff must read the instruction manual thoroughly before using the products. Do not operate the pump system unless all of the contents in the manual are completely understood.

Caution

- **Turn off the power supply**

Working without disconnecting the power supply may cause an electrical shock. Before engaging upon any working procedures involving the pump, make sure to turn the power supply switch off and to stop the pump and other related devices.

- **Terminate operation**

When you detect or become aware of a dangerous sign or abnormal condition during operation, terminate the operation immediately and start it from the beginning again.

- **Specified power only**

Do not operate the pump on voltage which is not specified on the nameplate. Failure to do so may result in damage or fire. Only the specified power level is to be applied.

- **Keep from heat or flame**

Do not place any dangerous materials or flammable objects near the pump for the prevention of fire or accident.

- **Damaged pump**

Never operate a damaged pump. A damaged pump may cause leakage or electrical shock.

2. Notes on operation

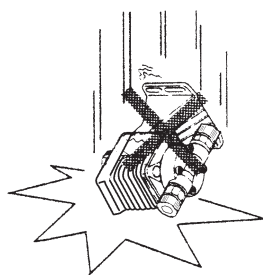

- Dropping the pump or subjecting it to strong impacts may result in faulty performance. Handle the pump with care.

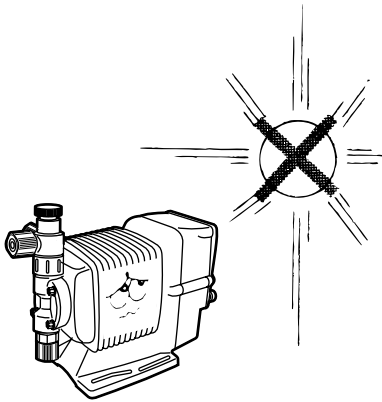

- The pump can be operated outdoors, as the pump employs a simple water and dust proof structure. However, when installing the pump, avoid places exposed to direct sunlight or direct rain with an ambient temperature of above 40°C, or with a relative humidity of above 90%. Though the pump has a simple waterproof and dustproof structure, a sheltered location is recommended.

- Select an installation site convenient for future maintenance and inspection, and fix the pump on a level floor so that it is free of vibrations.

- Ventilate
Ventilate the operating site sufficiently when toxic or odorous liquid is handled.



Prohibited

- Do not wet or dampen
If an electric part or wiring gets wet with the liquid spilled over accidentally, a fire or electrical shock may be caused. Install the system in a place free from liquid spillage or leakage.

- Install an earth leakage breaker
The operation of a pump without using an earth leakage breaker may cause an electrical shock. Please install an leakage breaker in the system.

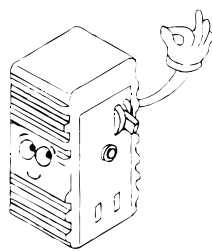

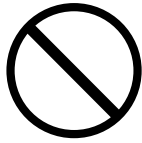

Prohibited

- Limited operating site and storage

Do not install or store the pump in the following places:

- * Places where a flammable gas or material is used or stored.
- * Place where the ambient temperature is extremely high (40°C or higher) or extremely low (0°C or lower).

- Cleaning

Wiping the pump body or the nameplate with a cloth soaked in a solvent such as benzene, thinner or kerosene may remove or change the color of the coating. Use a dry cloth or a cloth soaked in water or neutral detergent.

3. Installation, Piping, and Wiring

Caution

- When you detect or become aware of a dangerous sign or abnormal condition during operation, stop the operation and restart the procedure from the beginning.

■ Installation

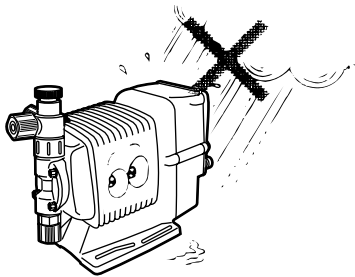

[1] Installation

Install the pump at a site where the ambient temperature does not exceed 40°C and the relative humidity does not exceed 85%. (There should be no dew condensation inside the control unit.) The site must be selected keeping in mind ease and efficiency for maintenance and inspection work.

[2] Place the pump as close to the suction tank as possible, allowing a flooded suction system (where the pump is located lower than the suction-side tank).

[3] If the pump is used to feed liquid that generates air bubbles easily (sodium hypochlorite, hydrazine solution, etc.), it must be positioned in a cool, dark place away from direct sunlight.



Caution

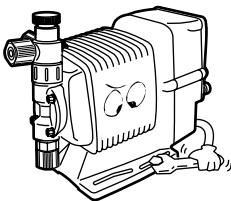

side view of tube

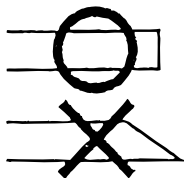

[4] Anchoring pump

Select a level floor free of liquid splash, and use M5 screws to firmly anchor the pump so as not to allow any vibration. If the pump is inclined, the discharge volume may be decreased considerably and may lose prime.

[5] Preparation of tube

Before the installation of the pump, cut the ends of the tube squarely.

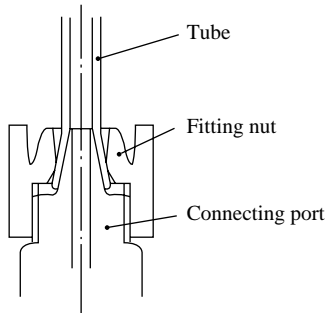

■ Piping

<For material codes VC, VH, PC, PH, TC>

[1] Piping for pump connection port

Use the tube with the correct diameter and make sure the connecting section does not cause liquid leakage or air suction.

⚠ Caution

Since the fitting nut is made of plastic resin, do not fasten it too tightly. This may destroy the part.

[2] Piping for air elimination process

For the safety, connect a tube to the discharge port of the air vent unit so that the eliminated air can be discharged into the suction tank or like.

[Note]

The F30, G30, G35 and G45 types are not equipped with an air vent unit.

<For material code SH>

- 1) Connection port is Rc1/4 female threads. Use proper size of pipe and securely connect pipe so that liquid can not leak or air can not be sucked in.
- 2) Screw the attached male connector in the bleed port.
- 3) Connect hose of 4 mm dia. to the male connector.
Return the hose end to the tank.
- 4) Adjust the direction of discharge port to any desired direction.
 - a. Turn the lock nut to left with wrench.
 - b. Adjust the direction of discharge port.
 - c. Holding the air vent body A by hand, turn the lock nut to right to tighten it.
 - d. Turn the lock nut to left by one fourth turn with wrench.

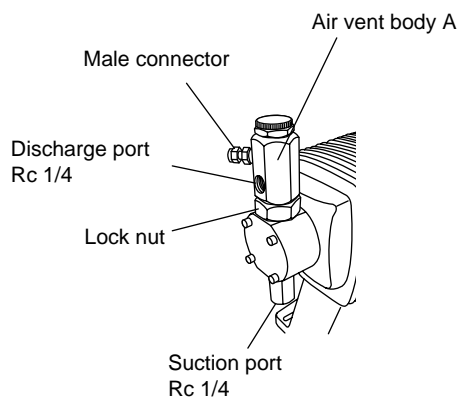

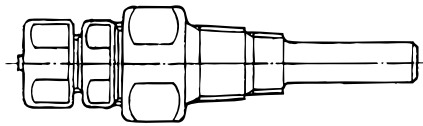

CA Type Check Valve

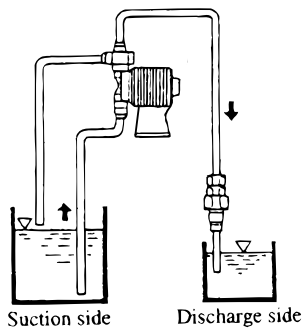

Fig. A

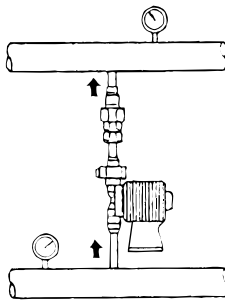

Fig. B

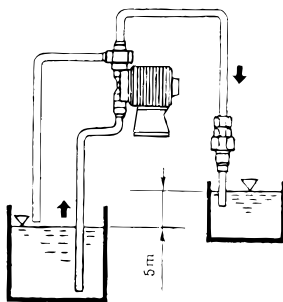

Fig. C

[3] Installation of check valve (Optional accessory)

The check valve is used to prevent overfeeding. The check valve must be installed in any of the following cases.

- (1) In case the suction-side liquid level is higher than that of the discharge-side level. (Liquid level is opened to atmosphere.) (Fig. A)
- (2) In case the pressure on the suction side is higher than on the discharge side (Fig. B)
- (3) In case the discharge-side liquid level is higher than that of the suction-side and the difference of the two levels is 5 m or less (Fig. C)
- (4) In case loaded pressure (piping resistance, discharge head, etc.) applied on the pump is 0.13 MPa or less. (0.049 MPa or less for F30, G35, G45)

- Install the check valve at the end of the discharge-side plumbing. It must be 1 m or more away from the pump.

⚠ Caution

As CA type uses Hastelloy spring at wet end, CA type could not be used for chemicals (Hydrochloric acid etc) which corrode Hastelloy. Select BVC type for this application.

■ Wiring of external signal cord

Caution

- Only qualified operators/service staff should be in charge of the related electrical arrangement and control of the power source. Failure to observe this instruction may result in injury to person or damage to assets.
- Never do the wiring when the power is switched on and the pump is operating to avoid electrical shock to the person and pump damage.

● Procedure to connect the external signal cord

Use DIN connector of five poles and four poles.

Following connectors made by Binder in Germany are recommended. Ask IWAKI for the detail of Binder connector.

5 poles: 713 Series 99-0436-10-05

4 poles: 715 Series 99-0430-15-04

Following procedures are based on the connector made by Binder in Germany.

If a similar connector is used, the wiring should be made according to the instruction manual of the manufacturer of connector.

- (1) Disassemble the connector and pass the wire through it. Cable outside diameter to be used is $\phi 4 - \phi 6$. If other diameter cables are used, the connector can not seal properly.

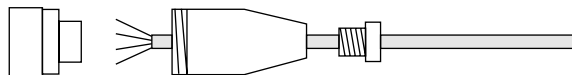

- (2) Strip the wire ends and insert them to the appropriate positions and tighten them by screws. Max. allowable cross section of the wire is 0.75mm^2 .

- (3) After the screws are tightened, tighten other parts securely. Slightly pull the cord to confirm that the cord is tightly secured. If the cord is loose, perfect sealing can not be obtained.

Terminal position

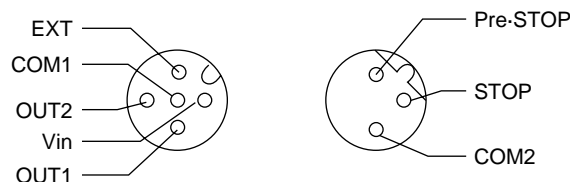

● **Connection of level sensor**

The controller corresponds to two stage level sensor. Connect pre-alarm signal to Pre-STOP and alarm signal to STOP. When the pre-alarm signal comes in, orange lamp is lighted but the pump does not stop. When one contact type is used, connect the wires to STOP and COM2.

- For open collector output level sensor
Pay attention to the polarity. Pre-Stop and STOP are plus (+), and COM2 is minus (-). (Max. charged voltage 5V, Current 1.1mA)
- For contact output level sensor, use the one designed for electronic circuit and minimum applicable load of 1 mA or less.

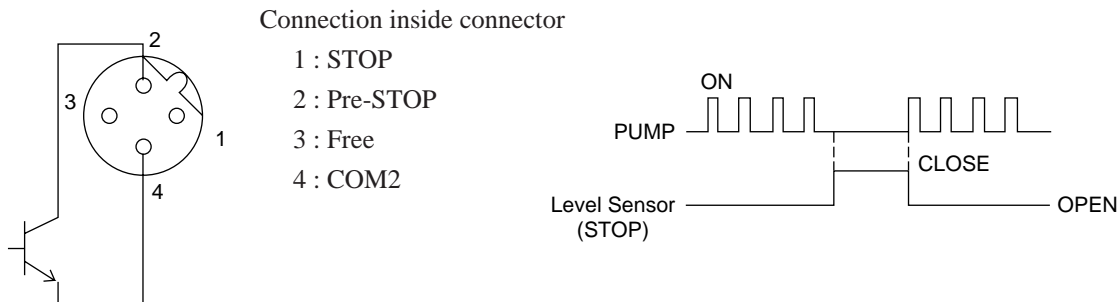

● **Stop function**

Stop function means the function to stop the pump by external potential free contact signal. Connect the wires to STOP and COM2 which is the same way as the level sensor connection.

● **Pulse signal input**

Pulse signal input is used when the pump is operated with EXT mode.

The EXT mode means that the pump makes one shot per external pulse signal which is activated by the control device or like. (It should be max. 3Hz = 180 spm or less)

- In case of open collector signal
Pay attention to the polarity. EXT is plus (+) and COM1 is minus (-). (Max. chargeable voltage 5V, Current 1.1mA)
- In case of contact such as relay or like
Use the one designed for electronic circuit and minimum applicable load of 1 mA or less.

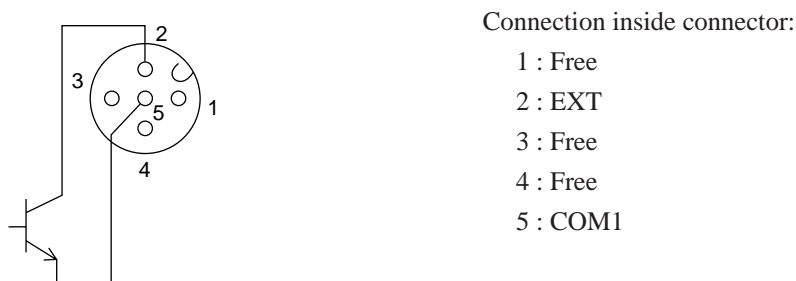

● Output signal

OUT1 : STOP output

Output signal is activated when the pump stops by the external signal such as level sensor or so.

OUT2 : Output synchronous with stroke

Signal is activated synchronous with each pump stroke (shot).

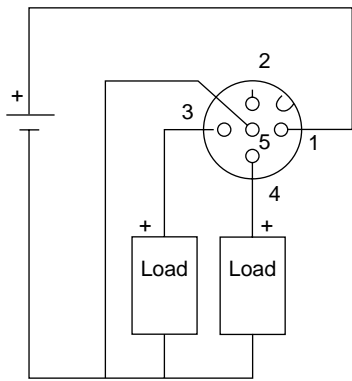

Connection inside connector:

- 1 : Vin
- 2 : Free
- 3 : OUT2 (Output synchronous with stroke)
- 4 : OUT1 (Stop output)
- 5 : COM1

External power source voltage depends on the load charged but it must be DC24V or lower.

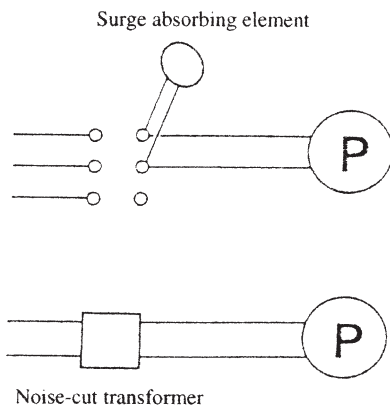

● Surge voltage

The electronic circuit of the control unit may be affected by excessively high surge voltage. So, do not operate the pump near high-power electrical equipment of 200V or above that generates high surge voltage.

Under unavoidable circumstances, take either of the following measures.

- (1) Use a surge absorbing element (such as a varistor with surge resistance of 2000A or more) at the pump power supply connection.
- (2) Use a noise-cut transformer.

PUMP OPERATION

1. Bleeding	27
2. Adjustment of flow rate.....	29
3. Operation	31

1. Bleeding

After the installation, piping, and wiring processes are completed, operate the pump in accordance with the following steps.

Caution

- **Do not operate the pump with a completely closed discharge-side valve.**
Operating the pump with the discharge-side valve fully closed may lead to liquid leakage or pipe rupture. Make sure not to operate the pump with the discharge-side valve closed.
- **Do not run the pump dry.**
A pump which has been run dry may experience liquid leakage during its liquid feeding operation. Make it sure to run the pump after supplying liquid inside the pump.
 - * Dry operation of the pump over a long time may cause the pump to overheat and the pump unit (pump head, valve case, etc.) to become deformed or the pump head attachment to become loose, which may result in liquid leakage trouble.
- **Keep the pump head firmly assembled.**
If the installation bolts on the pump head are loosened, liquid leakage may result.
 - * Fasten the 4 hex,socket bolts tightly before starting the initial pump operation. (The bolts may be loosened during storage or transportation of the pump, depending upon the condition of each.)
 - * Fastening torque: 2.16 N·m for EW-08, 10, 15 & 20, 2.55N·m for EW-30, 2.95N·m for EW-35, 45.
Tighten all the bolts fully by applying an equal amount of torque in a diagonal order among the bolts.

■ Bleeding

Bleeding is a process undertaken to eliminate air inside the suction-side tube and the pump head. Make sure to carry out bleeding prior to the initial operation of the pump and/or after replacing the liquid in the tank. For safe bleeding, first set a pipe to the air-vent port of the air vent unit.

Warning

Some liquids used in pump feeding may cause skin trouble or affect the quality of a mechanical part. Wipe off the liquid immediately when it wets your hand or a mechanical part.

VC, VH, PC, PH, TC types

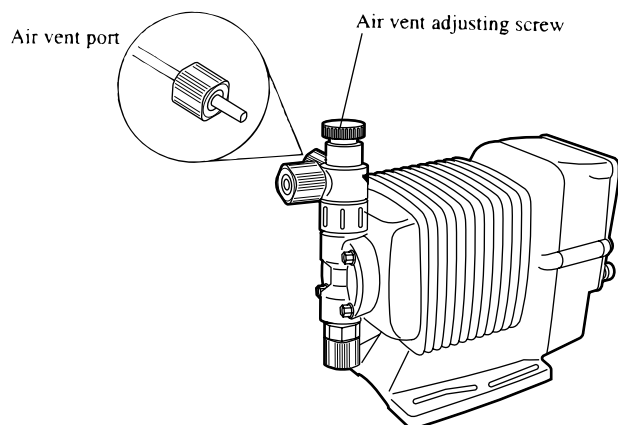

<Bleeding for EW-B08, F10, 15, 20 and G20>

- [1] Start the pump. See the clause "Operation" to operate the pump.
- [2] Rotate the air vent adjusting screw counterclockwise (almost half a turn) to open the air vent port.
- [3] Operate the pump under this condition for longer than 10 minutes for a complete removal of air.

SH type

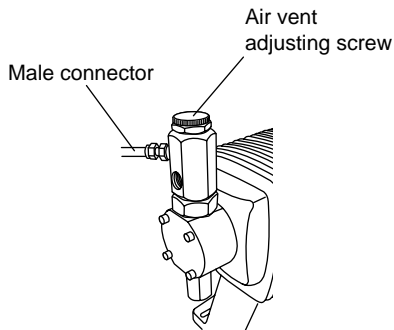

[4] Rotate the air vent adjusting screw clockwise to close the air vent valve

[5] Inspect various points for liquid leakage to complete the air elimination process.

<Bleeding for EW-F30, G30, 35, 45 models>

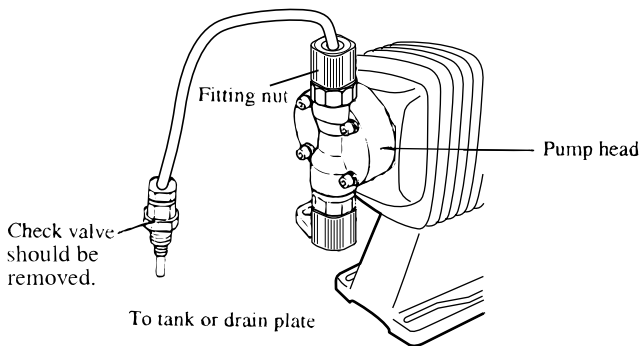

[1] Extend the tube connected with the discharge-side fitting nut of the pump to the liquid tank or something like a drain plate. Then, start pump operation.

- Remove the check valve if it is installed on the discharge-side.

[2] Adjust the stroke rate to full speed, and continue operating the pump for about 10 minutes to eliminate the air completely.

[3] When the air in the pump head is completely eliminated and replaced with liquid, return the discharge-side tube to the regular piping position.

[4] Finally, make sure there is no leakage in any section.

2. Adjustment of flow rate

The discharge amount can be adjusted by two methods, namely, stroke speed adjustment and stroke length adjustment, the former being used in most cases. In the event the expected discharge is not exactly obtained by the stroke speed adjustment, the stroke length adjustment is employed as a supplementary.

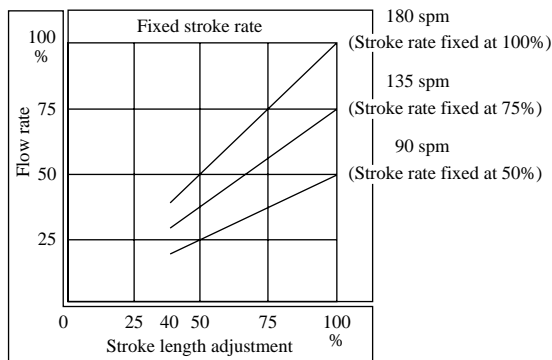

[1] Procedure for flow rate adjustment

Determine the appropriate stroke rate and stroke length based on pump operation conditions and liquid properties. The following method is recommended to determine the set values in consideration of pump performance features.

(1) Set the stroke length at 100% and then adjust the stroke rate so that an approximate discharge amount is arranged.

(2) Measure the discharge amount.

(3) If the discharge amount actually measured is lower than required, increase the stroke rate. Then, measure the discharge amount again.

(4) Adjust the stroke length, this time for the purpose of fine adjustment of the discharge amount.

(5) Measure the discharge amount and check that the set amount is precisely discharged.

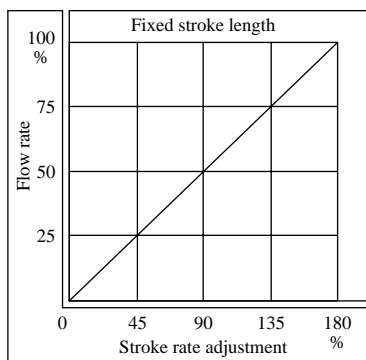

[2] Adjustment of stroke rate

See the clause "Operation" to change stroke rate.

- The stroke rate per minute of the plunger is controlled by the control unit within a range of 1~180 spm.

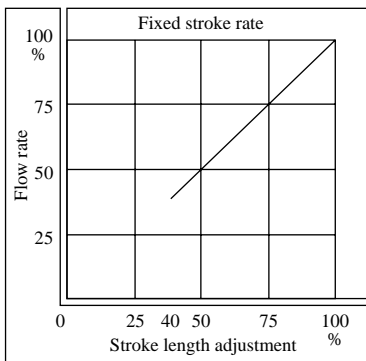
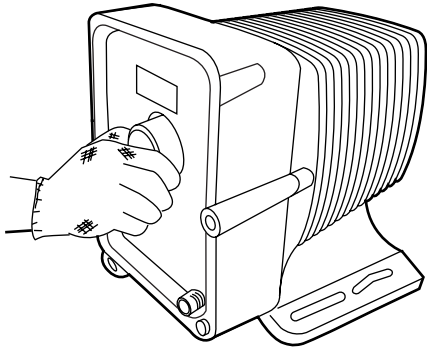

[3] Adjustment of stroke length

Stroke length can be adjusted by changing the degree of plunger return.

- (1) Start the pump and rotate the stroke length adjusting dial while operating the pump to adjust the discharge amount.
- (2) The relation between discharge amount and stroke length is as shown in the graph on the left, where the discharge amount is indicated in percentage.
 - The degree of plunger is variable in a range from 0 to 100%. Nevertheless, the usage between 40% and 100% is practical.

Caution

Do not rotate the stroke length adjusting dial when the pump stops.

Notice

- (1) For the liquids that easily generate air bubbles (sodium hypochlorite, hydrazine solution etc.), the flow rate should be adjusted by changing the stroke rate keeping the stroke length at about 100%. If stroke length is short, desired flow rate may not be obtained.
- (2) If the back pressure on the discharge side is high, adjust the flow rate by changing stroke rate keeping the stroke length at about 100%.

In the application of neutralization or titration etc., if the reaction is greatly influenced by the volume per shot of pump, adjust the flow rate by stroke rate adjustment keeping the short stroke length to minimize the volume per shot.

3. Operation

■ Control panel

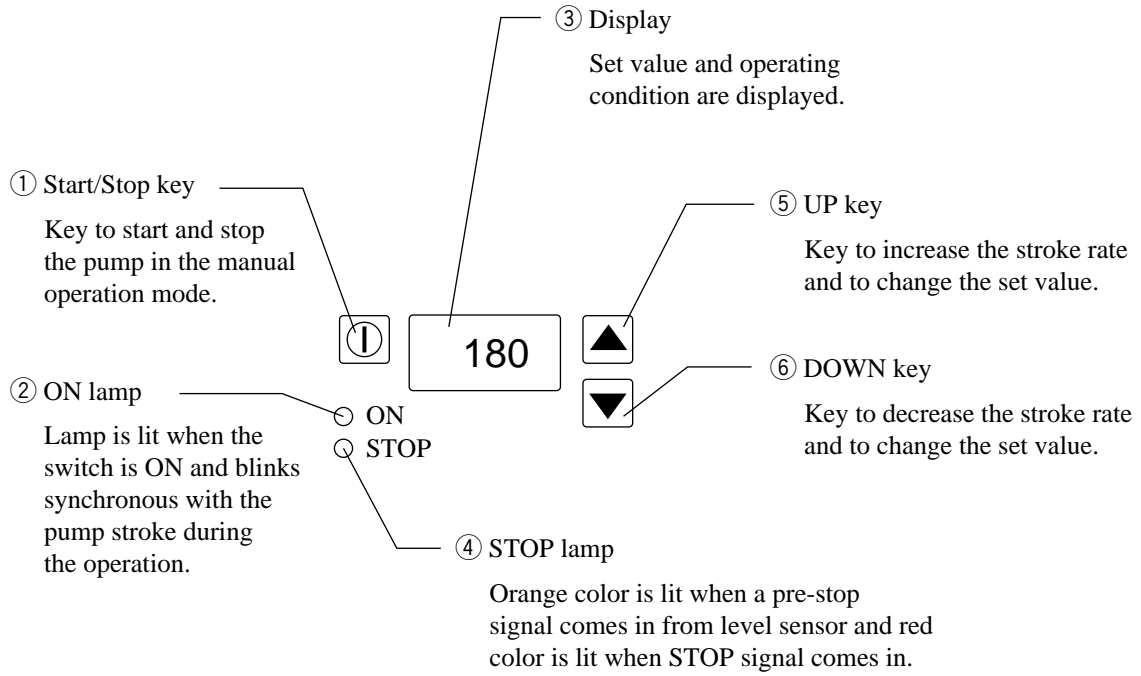

■ Basic display

180	Stroke rate is displayed.
EXT	EXT operation is displayed.
T-5	Display for chattering absorption function

■ Main menu

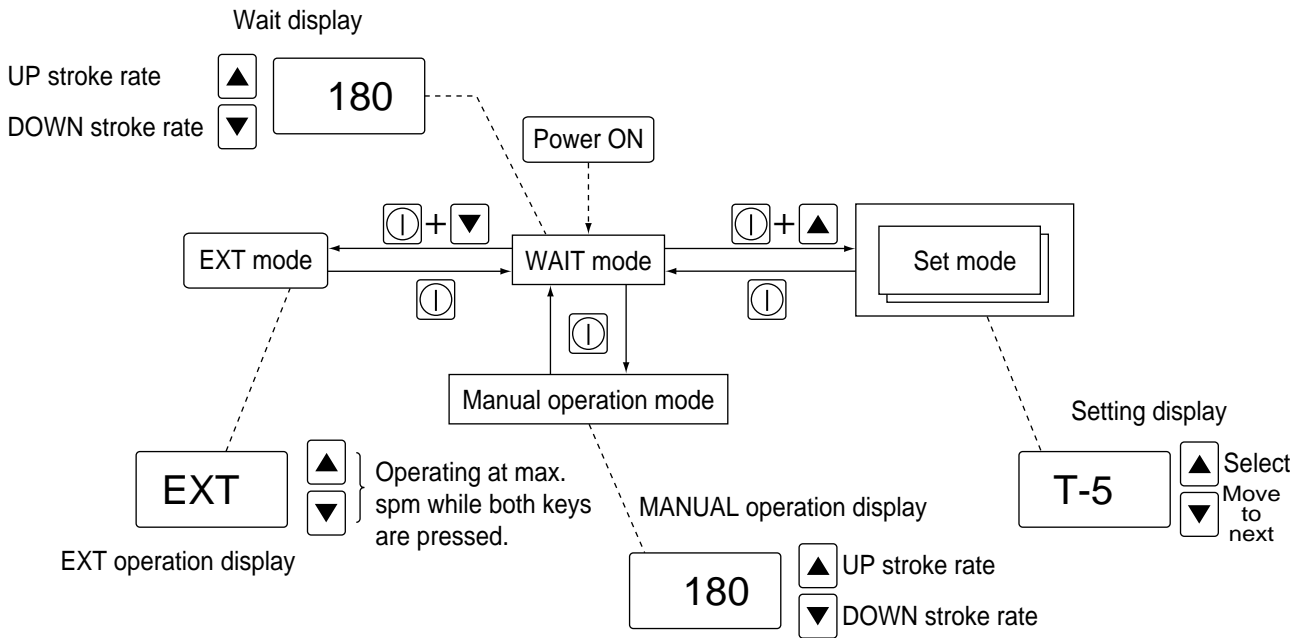

1. -----> means automatic move. After the program version code is momentarily displayed, it automatically moves to the status at which the power is switched off last time. (When the power is ON for the first time, it becomes WAIT mode.)
2. For the manual operation, the pump starts when (1) START/STOP key is pressed at WAIT mode. To stop the pump, it returns to WAIT mode when (1) START/STOP key is pressed again.
3. For EXT operation, press (1) START/STOP + ▼ keys at the same time to start the operation. For the stop of EXT operation, press (1) key to come back to WAIT mode.
4. For the SET mode, press (1) + ▲ keys at the same time. Setting is done by ▲ key, and press ▼ key to move to next setting.

Refer to following pages for details.

■ Operation

Power ON

180

When the power is ON, the display shows WAIT mode after the program version code is momentarily displayed. (When the power is switched on initially.)

Once the initial power is switched on, it returns to the mode at which the power was off last time. (In case the power was off at SET mode, WAIT mode comes first.)

- At the WAIT mode, stroke rate is displayed. ON lamp is lighted.

Manual operation

180

① Start and stop (Manual operation)

To start manual operation, press ① START/STOP key once. ON lamp is flashed.

If ① START/STOP key is pressed again, ON lamp is lit and it displays WAIT mode.

② Change of stroke rate

Stroke rate is set by ▲ and ▼ keys. Press ▲ key to increase and ▼ key to decrease the figure. If the keys are held for more than 3 seconds, the figures change quickly. The change of stroke rate can be done while the pump is running or stopped (WAIT mode)

65

EXT operation

180

EXT

▲ + ▼

Release key

180

180

① Moving to WAIT mode

If it is in Manual operation mode or SET mode, change to WAIT mode once. If it is in WAIT mode, go to next.

② Moving to EXT mode

To move to EXT mode, press ① START/STOP and ▼ keys at the same time. In this EXT mode, the pump is operated automatically corresponding to external pulse signal.

③ Manual operation during EXT operation

Although EXT mode is automatic operation, the pump operates at 180 spm while ▲ and ▼ keys are pressed at the same time. If either one of keys is released, then it returns to EXT mode.

Use this way when you wish to do bleeding during EXT operation or when you wish to run pump without a pulse signal.

④ Moving to WAIT mode

Press ① START/STOP key to move to WAIT mode from EXT operation. When it comes to WAIT mode, the display shows the spm at which the MANUAL operation is done and the pump stops.

Setting of function

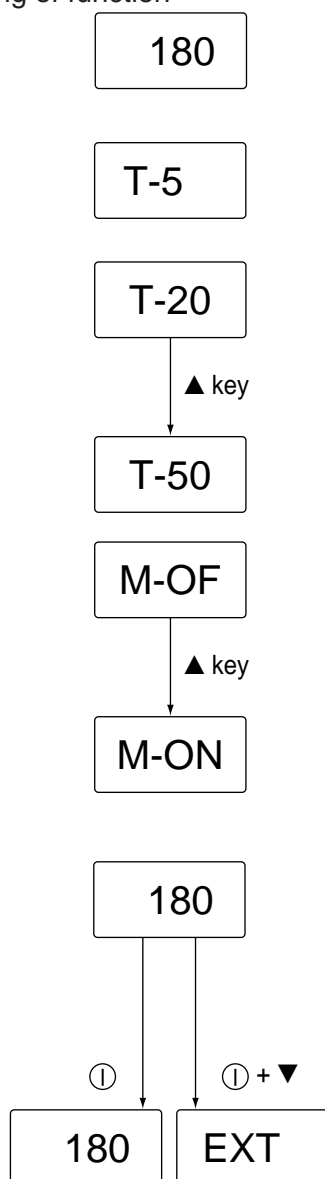

① Moving to WAIT mode

If it is in MANUAL operation or in SET mode, set to WAIT mode. If it is in WAIT mode, go to next step.

② Moving to SET mode

Press ① START/STOP and ▲ keys at the same time and it displays anti-chattering function.

③ Setting of anti-chattering function

Press ▲ key to change input pulse signal. Everytime the key is pressed, the display changes to "T-5", "T-20" and to "T-50". Select the appropriate figure corresponding to the chattering condition of the signal. When no problem is found, select "T-5" (factory shipment status) and set the large figure for the noisy signal. Press ▼ key to move to next setting.

④ Setting of STOP function

"M - OF" and "M - ON" is displayed alternatively every time when ▲ key is pressed. To stop the pump by closing the contact when the signal enters, select "M - OF" and select "M - ON" to stop the pump by opening the contact when the signal enters.

(If ▼ key is pressed here, it comes to the mode of anti-chattering function setting.) Press ① START/STOP key to move to WAIT mode. Setting is memorized by pressing ① START/STOP key.

⑤ Operation

Start the pump operation when the function setting is completed.

Press ① START/STOP key once for MANUAL operation. Press ① START/STOP and ▼ keys at the same time for EXT operation.

■ Parameters

Following table shows the parameters and setting range for each mode.

Mode	Parameter	Initial value	Set range
MANUAL	SPM	180 spm	1 - 180
SET	Chattering	T - 5	T-5, T-20, T-50
	STOP	M - OF	M - OF, M - ON

MAINTENANCE

1. <i>Causes of Trouble and Troubleshooting.....</i>	36
2. <i>Maintenance and Inspection</i>	37
3. <i>Disassembly and Reassembly</i>	38
4. <i>Accessories.....</i>	42
5. <i>Names of Parts and Structure.....</i>	43

1. Causes of Trouble and Troubleshooting

Handling, repair, inspection, disassembly or assembly must be carried out in accordance with each related section included in this instruction manual. Do not try to carry out a service or maintenance work beyond or against the descriptions included in this manual. Iwaki takes no responsibility for injuries or damages to assets caused by the user's failure to observe the instructions mentioned in this manual.



Warning

- **Wear protectors.**

If you touch or come in contact with any type of hazardous chemical liquid, including but not limited to chemicals, you may experience a serious injury. Wear protective gear (protective mask, gloves, etc.) during the pump operation.

- **Turn off the power supply.**

Working without disconnecting the power supply may cause an electrical shock. Before engaging upon any working procedures involving the pump, make sure to turn the power supply switch off and to stop the pump and other related devices.

Trouble	Cause	Troubleshooting
Pump does not start.	<ul style="list-style-type: none"> ● Faulty wiring or disconnection in wiring ● Lowered voltage ●  START/STOP key is not pressed. ● Electronic circuit of control unit is damaged. 	<ul style="list-style-type: none"> ○ Correct wiring. ○ Trace cause and raise voltage to specified level. ○ Press  START/STOP key. ○ Replace the whole unit. (Components cannot be repaired.)
Liquid cannot be sucked in.	<ul style="list-style-type: none"> ● Air suction in suction piping ● Valve gasket is not installed. ● Valve set assembling direction is wrong. ● Pump is air-locked. ● Pump stroke length is too short. ● Suction-side/discharge-side valve is clogged with foreign matter. ● Adhesion of valve onto valve seat 	<ul style="list-style-type: none"> ○ Set piping normally. ○ Install valve gasket. ○ Reassemble valve set. ○ Bleed air. ○ Drive pump with stroke length set at 100%. Then, reset stroke length. ○ Disassemble, inspect, and clean. ○ Disassemble, inspect, and clean.
Discharge amount fluctuates.	<ul style="list-style-type: none"> ● Suction-side/discharge-side valve is clogged with foreign matter. ● Air is trapped in pump. ● Overfeeding ● Diaphragm is damaged. 	<ul style="list-style-type: none"> ○ Disassemble, inspect, and clean. ○ Bleed pump. ○ Install check valve. ○ Replace diaphragm.
Liquid leaks.	<ul style="list-style-type: none"> ● Valve or connecting port is not sufficiently tightened. ● Pump head is not tightly fastened. ● Diaphragm is damaged. ● O ring and valve gasket are not installed. 	<ul style="list-style-type: none"> ○ Tighten fittings. ○ Tighten pump head bolts. Torque: 2.16 N·m ○ Replace diaphragm. ○ Install O ring and valve gasket.





2. Maintenance and Inspection

■ Daily check

Pay attention to the following points during pump operation, and stop pump operation immediately in the event of an abnormality. Take the necessary measures, with reference to the “Causes of Trouble and Troubleshooting” section (p.32). Replace the expendable parts with new ones in accordance with the replacement timing specified below.

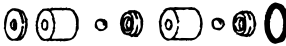
No.	Check Point	Details	How to Check
1	Does pump discharge liquid normally?	<ul style="list-style-type: none"> Is liquid normally fed? Is suction pressure/discharge pressure at normal level? Has liquid undergone quality change, crystallization, or solidification? 	<ul style="list-style-type: none"> By flow meter or visual inspection Check nameplate. By visual inspection
2	Abnormal noise or vibration?	<ul style="list-style-type: none"> Abnormal noise or vibration may result from abnormal functioning of pump. 	<ul style="list-style-type: none"> By visual and audio inspection
3	Is there liquid leakage or air suction at any joint on pump or piping?	<ul style="list-style-type: none"> Tighten joint where leakage has occurred. Excessive air bubbles in discharged liquid mean air suction has been caused in system. Examine the piping and tighten joint which leaks. 	<ul style="list-style-type: none"> By visual inspection

■ Expendable parts

	Part		Qty.	Replacement Timing	Remarks
	VC, VH, PC, PH, TC	SH			
Valve set			2 sets	Approx. 8,000 hrs.	* Number of parts applicable should be checked with reference to "Names of Parts and Structure of Pump" section.
Diaphragm			1		
O ring Valve gasket			*		

- The durability of expendable parts depends on the pressure, temperature, and properties of the liquid handled. The value in the above table has been obtained from a continuous test run of the pump using clear water at room temperature. Take the value as a guideline for replacement.

3. Disassembly and Reassembly

Follow the disassembly and reassembly procedures described below when disassembling or reassembling the pump as necessary for such purposes as replacing expendable parts or overhauling the pump for cleaning.

<Points to be confirmed before disassembly>

- Pay special attention to the presence of residual liquid inside the pump when disassembling the pump.
- Wash the wet-end parts in the pump head with water.

■ Replacement of valve set of material codes VC, VH, PC, PH, TC (Refer to pump unit disassembled view on pages 44)

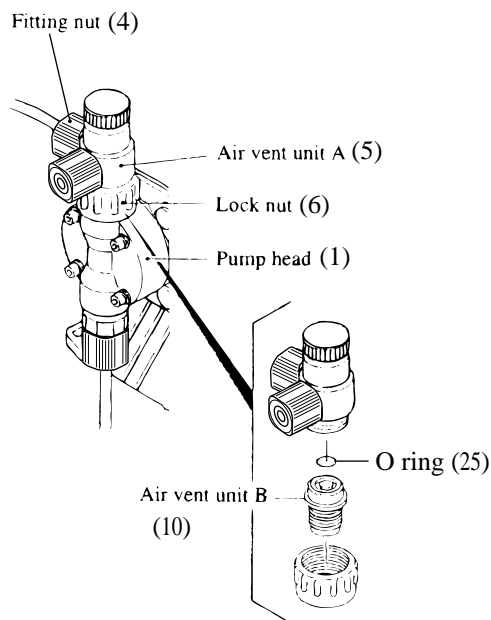

• EW-F30, G30, G35 & G45 types

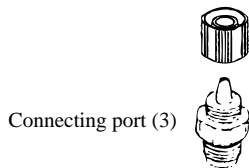

<Disassembly>

[1] Removal of the valve set on the discharge side

(1) Loosen the fitting nut and detach the tube to the pump. Pay attention to any residual liquid which may flow out of the end of the disconnected tube.

(2) Use a pair of pliers or similar tool to turn the lock nut(6) counterclockwise to remove the air vent unit A(5).

(3) Use a wrench to loosen and remove the air vent unit B(10). Then, take the valve set out of the pump head.

- In the case of EW-F30, G30, G35 & G45 types, use a wrench to loosen and remove the connecting port(3). Then, take the valve set out of the pump head(1).

[2] Removal of the valve set on the suction side.

(1) Loosen the fitting nut(4) and detach the tube from the pump.

- Pay attention to the residual liquid which may flow out of the end of the disconnected tube.
- Use a wrench to loosen and remove the connecting port.
- If any element of the valve set thus removed is scratched or worn, replace the valve set with a new one.

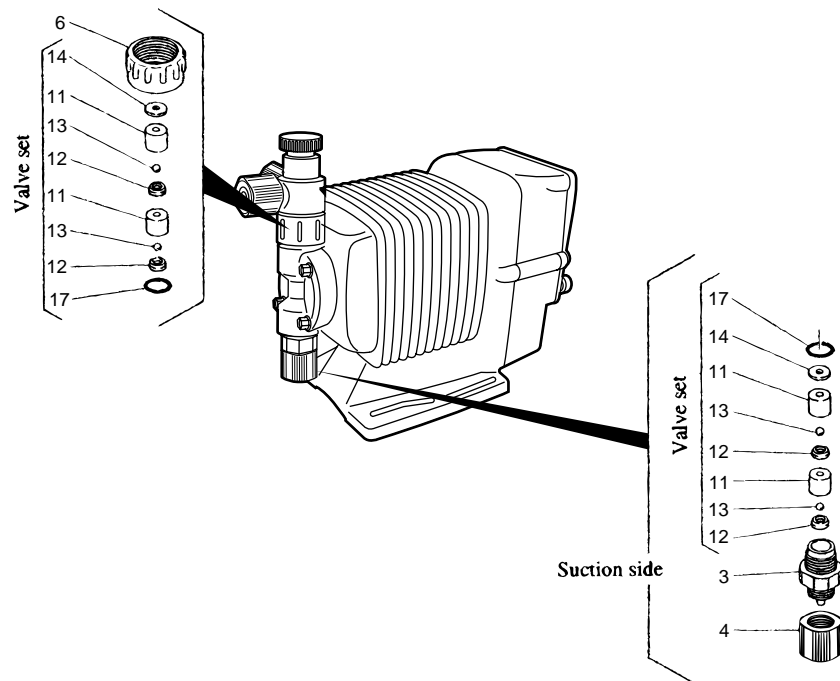

<Reassembly>

Reassemble the pump by following the disassembly sequence in reverse. Carefully monitor the following points to achieve a perfect reassembly.

- Be careful with the assembly positions and directions concerning the parts.
If the elements of the valve set are inserted in incorrect positions and/or directions, an abnormal liquid flow may result, for example liquid leaks or a reduction in discharge amount.
- Do not forget to insert the O ring(17) or valve gasket(14).

[3] Reassembly of the valve set on the discharge side

Position the valve set on the pump head(1). Then, insert the lock nut(6) into air vent unit B(10) and fasten the lock nut.

[4] Reassembly of the valve set on the suction side

Position the valve set on the connecting port(3) and fasten the connecting port by hand. Next, use a wrench to rotate the connecting port about 1/4 turn for further tightening.

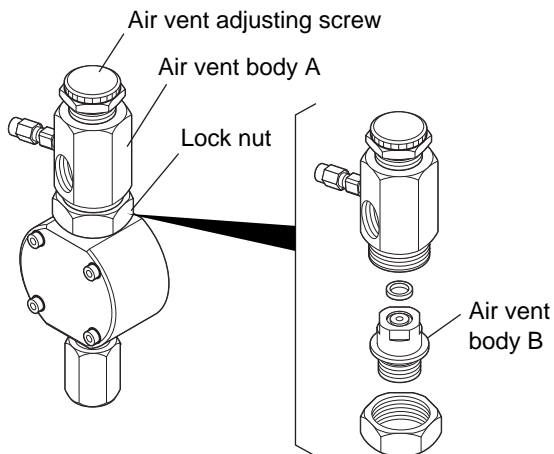

■ Replacement of valve set of material code SH (Refer to pump unit disassembled view on page 45.)

<Disassembly of discharge valve>

- 1) Remove every hose and pipe.
- 2) Turn the lock nut to left with wrench to remove air vent body.
- 3) Loosen the air vent body B with wrench to remove it.
- 4) Remove the valve set with tweezers from pump head.

<Disassembly of suction valve>

Loosen the connection port with wrench to remove it and remove the valve set with tweezers.



Caution

Pay attention not to drop the valve set.

<Assembly of discharge valve set>

Put the valve set into pump head and screw in the air vent body B after lock nut is put on it.

<Assemble of suction valve set>

Put the valve set in the connection port, screw it into pump head by hand and tighten it by wrench by turning it by one fourth turns.



Caution

Pay attention not to put the parts in wrong order and upside down. Wrong mounting of parts will cause failed pumping or abnormal pressure increase.



Caution

Do not forget to put O ring and gasket.

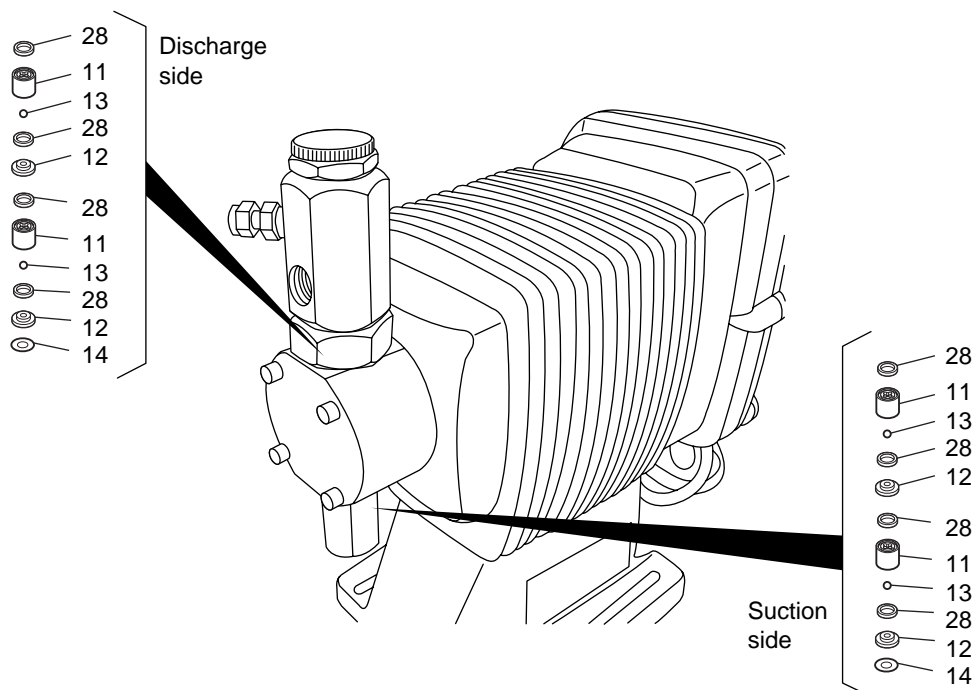

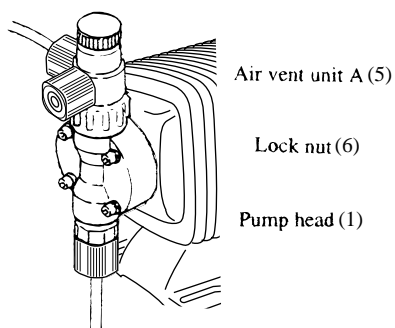

■ Air vent assembly

Use a wrench to loosen the lock nut(6). Since the air vent unit(A) can be rotated 360 degrees, the tube connection position can be selected freely to satisfy your requirements. The lock nut shall be loosened to make sure that the tube is not positioned over the pump head. Then, fix the position by fastening the lock nut. When fastening the lock nut, hold the air vent unit A(5) with your hand and rotate the lock nut clockwise when viewed from above the pump unit by hand. Then, use a wrench to rotate the lock nut about 1/4 turn for further tightening.

■ Replacement of diaphragm

<Disassembly>

[1] Loosen the four hex. socket bolts(19) with a hexagon L-shaped wrench to detach the pump head(1) from the pump body.

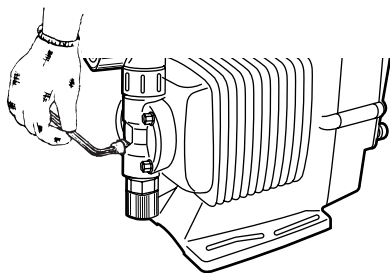

[2] Hold the periphery of the diaphragm(7) and rotate the diaphragm counterclockwise to detach it from the plunger pin.

- In some cases, some diaphragm spacers are inserted behind the diaphragm and retainer for positioning. Be careful not to misplace them when replacing the diaphragm.

<Assembly>

To reassemble the diaphragm, follow the disassembly sequence in reverse, paying attention to the following points.

[1] Prior to reassembly, set the pump stroke length at 100%.

- First, start the pump for stroke length setup. Then, stop the pump and disconnect the power supply.

[2] Insert the retainer(9) and diaphragm spacers(18) into the screwed section of a new diaphragm and screw the diaphragm onto the plunger pin.

- Set the concave side of the retainer on the stepped screw section of the diaphragm so that it will not come off.

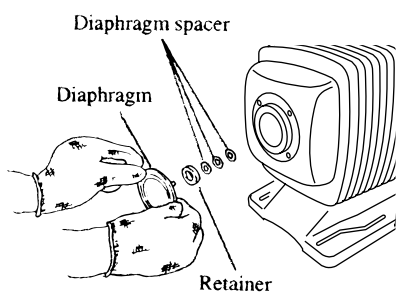

[3] Attach the pump head onto the pump body.

Tighten the four hex. socket bolts by applying an equal amount of torque to them.

• Tightening torque:

EW-08, 10, 15, 20 : 2.16N·m

EW-30 : 2.55N·m

EW-35 · 45 : 2.95N·m

4. Accessories

■ Specification of check valve(CA, CS), back pressure valve(BVC) (Optional Items)

Type	Set Pressure MPa	Diameter of Fitting mm	Material of Liquid Contacting Parts	Applicable Pump	Material Code of Liquid Contacting Parts of Pump	
CA-1V-4×6	0.17 ± 0.04	φ4 × φ6	CFRPP	EW-B08, F10·15·20 EW-G20	PC	
CA-1E-4×6					PH	
CA-2V-9		φ9 × φ12		EW-G30	PC	
CA-2E-9				PH		
CA-2VL-9	EW-F30 EW-G35·G45			PC		
CA-2EL-9				PH		
CA-1VC-4×6	0.17 ± 0.04	φ4 × φ6		PVC	EW-B08 EW-F10·15·20 EW-G20	VC
CA-1VE-4×6						VH
CA-1VC-6		φ6 × φ8	VC			
CA-1VE-6			VH			
CA-2VC-9		φ9 × φ12	EW-G30		VC	
CA-2VE-9			VH			
CA-2VCL-9			EW-F30 EW-G35·G45		VC	
CA-2VEL-9					VH	
BVC-1VV-4H	0.2 ± 0.02	φ4 × φ6	PVC	EW-B08 EW-F10·15·20 EW-G20	VC	
BVC-1VV-9H						φ9 × φ12
	0.10 ^{+0.02} _{-0.01}			EW-F30 EW-G35·G45		
CS-1S	0.2 ± 0.03	Rc 1/4	SUS316	EW-B08 EW-F10, 15 EW-G20, G30	SH	
CS-1SL	0.5 ± 0.03	Rc 1/4	SUS316	EW-G35, G45	SH	
BVC-1TV-4H	0.2 ± 0.02	φ4 × φ6	PVDF	EW-B08, F10, F15, G20	TC	
BVC-1TV-10H	0.2 ± 0.02	φ10 × φ12	PVDF	EW-G30	TC	
	0.1 ± 0.02			EW-G35, G45		

5. Names of Parts and Structure

■ Disassembled view

All the parts are shown as disassembled for a clear understanding of their names and the structure of the pump. For the procedures involved in disassembling the pump, make sure to observe the disassembly instructions included in the “Maintenance” section, without carrying out disassembly beyond the descriptions.

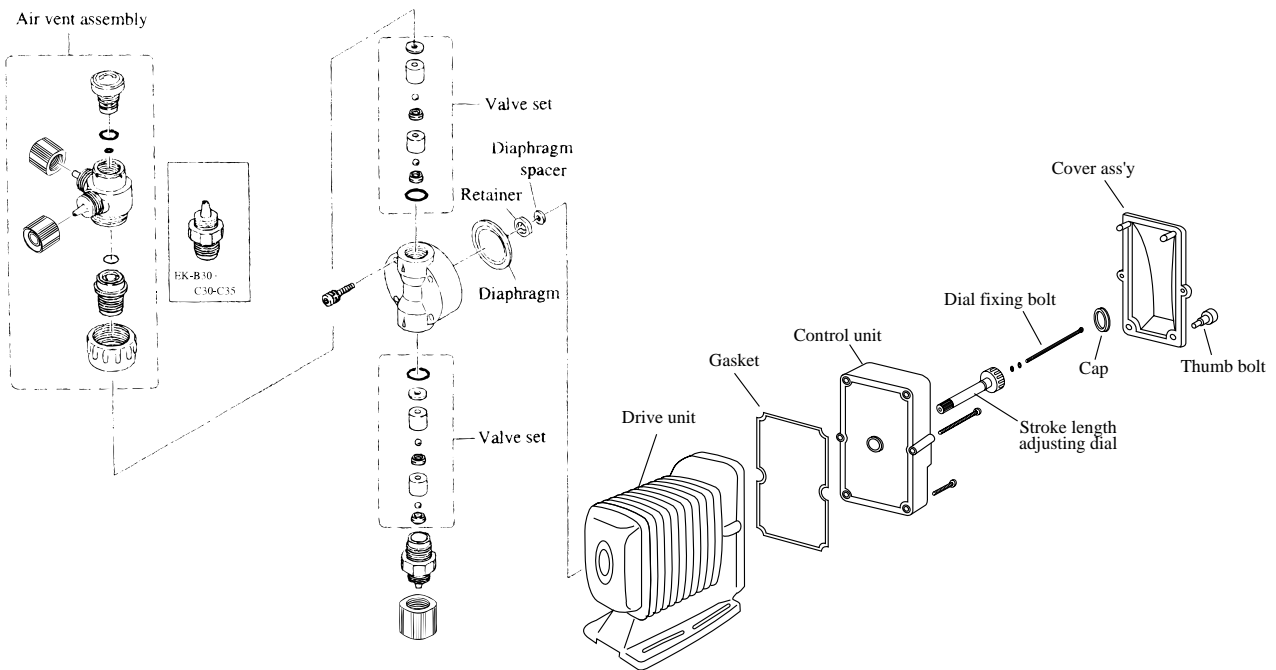

■ Pump Unit

- EW-B08, F10, F15, F20, G20 Types (VC, VH, PC, PH, TC)

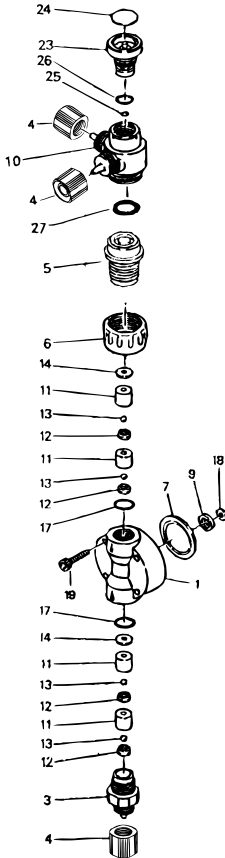

No.	Name	Quantity
1	Pump head	1
3	Fitting	1 (2)
4	Fitting nut	3 (2)
5	Air vent body B	1(0)
6	Lock nut	1(0)
7	Diaphragm	1
9	Retainer	1
10	Air vent body A	1(0)
11	Valve guide	4
12	Valve seat	4
13	Valve	4
14	Valve gasket	2
17	O ring	2
18	Diaphragm spacer	(Note 1)
19	Hex. socket cap bolt (with SW, PW)	4
23	Adjusting screw	1(0)
24	Name plate	1(0)
25	O ring	1(0)
26	O ring	1(0)
27	O ring	1(0)

- EW-F30, G30, G35, G45 Types (VC, VH, PC, PH, TC)

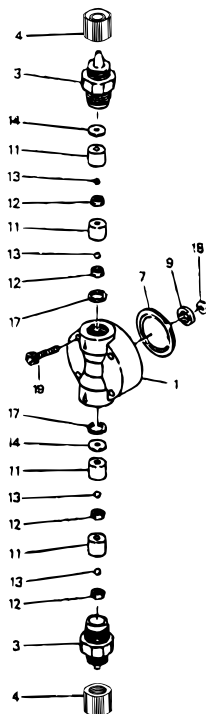

Note 1: The number of the diaphragm spacers, which are for dimensional adjustment, depend on the type of pump.

2: Quantity in parentheses is for EW-F30, G30, G35, G45.

● EW-B08, F10, F15, G20, G30, G35, G45 Types (SH)

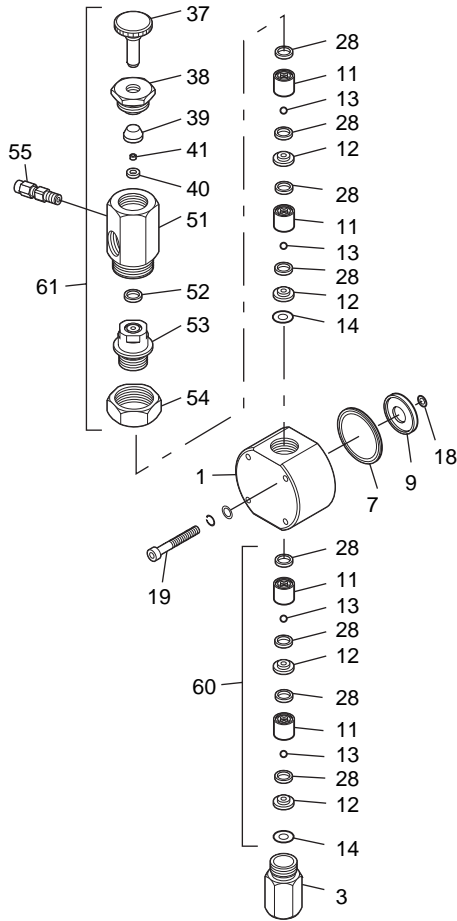

No.	Parts name	Q'ty
1	Pump head	1
3	Fitting	1
7	Diaphragm	1
9	Retainer	1
11	Valve guide	4
12	Valve seat	4
13	Valve	4
14	Valve gasket B	2
18	Diaphragm spacer	(Note)
19	Hex. socket cap bolt (with SW, PW)	4
20	Plate washer	4
21	Spring washer	4
28	Valve gasket A	8
37	Adjusting screw	1
38	Seal nut	1
39	Seal ring	1
40	Seat	1
41	Seat ring	1
51	Air vent body A	1
52	Gasket	1
53	Air vent body B	1
54	Nut	1
55	Male connector	1

Note : The number of the diaphragm spacers, which are for dimensional adjustment, depend on the type of pump.



IWAKI CO.,LTD. 6-6 Kanda-Sudacho 2-chome Chiyoda-ku Tokyo 101-8558 Japan
 TEL:(81)3 3254 2935 FAX:3 3252 8892(<http://www.iwaki-pumps.co.jp/>)

()Country codes

Germany	: IWAKI EUROPE GmbH	TEL : (49)2154 9254 0	FAX : 2154 1028	U.S.A.	: IWAKI WALCHEM Corporation	TEL : (1)508 429 1440	FAX : 508 429 1386
Italy	: IWAKI Italia S.R.L.	TEL : (39)02 990 3931	FAX : 02 990 42888	Australia	: IWAKI Pumps Australia Pty. Ltd.	TEL : (61)2 9899 2411	FAX : 2 9899 2421
Denmark	: IWAKI Pumper A/S	TEL : (45)48 24 2345	FAX : 48 24 2346	Singapore	: IWAKI Singapore Pte. Ltd.	TEL : (65)763 2744	FAX : 763 2372
Sweden	: IWAKI Sverige AB	TEL : (46)8 511 72900	FAX : 8 511 72922	Indonesia	: IWAKI Singapore (Indonesia Branch)	TEL : (62)21 392 8288	FAX : 21 392 8088
Finland	: IWAKI Suomi Oy	TEL : (358)9 2742714	FAX : 9 2742715	Malaysia	: IWAKIm Sdn. Bhd.	TEL : (60)3 7803 8807	FAX : 3 7803 4800
Norway	: IWAKI Norge AS	TEL : (47)66 81 16 60	FAX : 66 81 16 61	Taiwan	: IWAKI Pumps Taiwan Co., Ltd.	TEL : (886)2 8227 6900	FAX : 2 8227 6818
France	: IWAKI France S.A.	TEL : (33)1 69 63 33 70	FAX : 1 64 49 92 73	Thailand	: IWAKI (Thailand) Co.,Ltd.	TEL : (66)2 320 1303	FAX : 2 322 2477
U.K.	: IWAKI PUMPS (UK) LTD	TEL : (44)1743 231363	FAX : 1743 366507	Hong Kong	: IWAKI Pumps Co., Ltd.	TEL : (852)2 607 1168	FAX : 2 607 1000
Switzerland	: IWAKI (Schweiz) AG	TEL : (41)32 3235024	FAX : 32 3226084	China	: IWAKI Pumps Co., Ltd. (Guangzhou office)	TEL : (86)20 8130 0605	FAX : 20 8130 0601
Austria	: IWAKI (Austria) GmbH	TEL : (43)2236 33469	FAX : 2236 33469	China	: IWAKI Pumps Co., Ltd. (Beijing office)	TEL : (86)10 6442 7713	FAX : 10 6442 7712
Holland	: IWAKI Holland B.V.	TEL : (31)297 241121	FAX : 297 273902	China	: IWAKI Pumps (Shanghai) Co., Ltd.	TEL : (86)21 6272 7502	FAX : 21 6272 6929
Spain	: IWAKI Iberica Pumps,S.A.	TEL : (34)943 630030	FAX : 943 628799	Philippines	: IWAKI Chemical Pumps Philippines, Inc.	TEL : (63)2 888 0245	FAX : 2 843 3096
Belgium	: IWAKI Belgium n.v.	TEL : (32)1430 7007	FAX : 1430 7008	Korea	: IWAKI Korea Co.,Ltd.	TEL : (82)2 3474 0523	FAX : 2 3474 0221