WALCHEM WCDB, WFCB, WOZB
and WPAB Disinfection Sensors
 **Instruction Manual**

W A L C H E M

5 Boynton Road Hopping Brook Park Holliston, MA 01746
508-429-1110 508-429-7433 (fax) www.walchem.com

Notice

© 2007 WALCHEM Corporation
5 Boynton Road, Holliston, MA 01746 USA
(508) 429-1110
All Rights Reserved
Printed in USA

Proprietary Material

The information and descriptions contained herein are the property of WALCHEM Corporation. Such information and descriptions may not be copied or reproduced by any means, or disseminated or distributed without the express prior written permission of WALCHEM Corporation, 5 Boynton Road, Holliston, MA 01746.

This document is for information purposes only and is subject to change without notice.

Statement of Limited Warranty

WALCHEM Corporation warrants equipment of its manufacture, and bearing its identification to be free from defects in workmanship and material for a period of 24 months for electronics and 12 months for mechanical parts and electrodes from date of delivery from the factory or authorized distributor under normal use and service and otherwise when such equipment is used in accordance with instructions furnished by WALCHEM Corporation and for the purposes disclosed in writing at the time of purchase, if any. WALCHEM Corporation's liability under this warranty shall be limited to replacement or repair, F.O.B. Holliston, MA U.S.A. of any defective equipment or part which, having been returned to WALCHEM Corporation, transportation charges prepaid, has been inspected and determined by WALCHEM Corporation to be defective. Replaceable elastomeric parts and glass components are expendable and are not covered by any warranty.

THIS WARRANTY IS IN LIEU OF ANY OTHER WARRANTY, EITHER EXPRESS OR IMPLIED, AS TO DESCRIPTION, QUALITY, MERCHANTABILITY, FITNESS FOR ANY PARTICULAR PURPOSE OR USE, OR ANY OTHER MATTER.

*P/N 180307.C1
October 2007*

1.0 Introduction

The WCDB (chlorine dioxide), WFCB (free chlorine), WOZB (ozone) and WPAB (Peracetic acid) sensors consist of an amperometric sensor assembly and a flow cell. Assembly of these parts is required, so please read these instructions carefully. The sensor is capable of measuring the disinfectant in clean water or in water contaminated with debris thanks to our unique flow cell design.

The free chlorine sensor membrane is not compatible with water containing surfactants!

Sensor

The sensor assembly includes the sensor body with 6 meters (20 feet) of cable, a replaceable membrane cap, a 6-ml bottle of electrolyte fill solution, a clip ring and an o-ring. Make sure that all parts are included.

The oxidizer molecules diffuse through the membrane and in the acidic environment of the electrolyte fill solution, a redox reaction occurs at the electrodes in the sensor. The current generated by this reaction is converted to a robust voltage signal that is linear with the concentration of the oxidizer.

Flow Cell

The flow cell consists of a translucent flow cell body, mounting nut and o-ring. Make sure that all parts are included.

The flow cell is required to prevent bubble formation on the membrane and to provide proper flow velocity across the face of the membrane. The sensor will not read accurately if it is not installed in the flow cell, with a flow rate between 30 and 100 liters per hour, at an operating pressure of 1 atmosphere or less.

2.0 Installation

Assembling the Sensor



CAUTION: Wear gloves and safety glasses during assembly of the sensor since the electrolyte is a **STRONG ACID**. It is recommended to perform this operation over a sink with running water available. After using, re-cap any remaining electrolyte until the next use.

1. Remove the black protective tube from the electrode tip, and clean just the **tip** of the working electrode with the special abrasive paper supplied. Avoid touching the electrodes! Hold the pad with the special abrasive paper and rub the electrode tip over it, holding the electrode at a slight angle. Repeat several times at different angles.
2. Open the vial containing the membrane cap. Empty out the water. Make sure that only one grey band is in the groove covering the vent hole in the membrane cap. Fill the membrane cap to the top with the electrolyte fill solution. (The free chlorine membrane cap is shipped dry, and has only one band)
3. Hold the sensor body vertically with the tip pointing down and **SLOWLY** screw on the membrane cap until it is hand tight. **Be prepared for some electrolyte solution to squeeze out from the vent hole in the cap.**

4. Push the second grey band into the groove in the cap, making sure that the bands are smooth and flush.
5. Rinse your hands, the sensor, and all surfaces contaminated with electrolyte solution with running water. Check the sensor for leaks, especially at the membrane and the membrane cap threads. If any leaks are detected, tighten the membrane cap or replace it.
6. Push the cable onto the end of the sensor, aligning the pins with the holes. Turn the connector until hand tight to seal the cable connection.

Flow Cell Placement

Instructions for mounting the sensor into the process can vary greatly with the circumstances that are encountered in your application. Here are some general guidelines to assist you. Refer also to the typical installation drawings.

The sensor should be mounted such that the measuring surfaces will always stay wet. If the membrane dries out, it will respond slowly to changing disinfectant values for 24 hours, and if dried out repeatedly, will fail prematurely.

The flow cell should be placed on the discharge side of a circulation pump or downhill from a gravity feed. Flow into the cell must come from the bottom side that has the $\frac{3}{4}$ " x $\frac{1}{4}$ " NPT reducing bushing installed. **The reducing bushing provides the flow velocity required for accurate readings and must not be removed!**

A "U" trap should be installed so that if the flow stops, the sensor is still immersed in the water. The outlet of the flow cell must be plumbed to open atmosphere unless the system pressure is at or below 1 atmosphere. If the flow through the line cannot be stopped to allow for cleaning and calibration of the sensor, then it should be placed in a by-pass line with isolation valves to allow for sensor removal. Install the sensor vertically, with the measuring surface pointing down, at least 5 degrees above horizontal. (Refer to Installation drawings)

Flow rate regulation must be done upstream from the sensor, because any flow restriction downstream can increase the pressure above atmospheric and damage the membrane cap!

The sensor should be installed in an area where there is good solution movement and where it will respond rapidly to chemical additions. The placement of the sensor relative to the placement of chemical replenishment, along with the quality of the mixing, and the replenishment chemical flow rate are critical to accurate process control.

Installing Sensor into Flow Cell

1. Assemble the flow cell as shown below from the top down. The reducer should already be installed in the flow cell body.
2. Slide the 102586 nut over the membrane end of the sensor, followed by the 103419-T top washer, followed by the 103422 o-ring, followed by the 103419-B bottom washer, followed by the 103421 clip ring. The clip ring must be pushed up until it snaps into the groove in the sensor body.
3. Place the 102594 o-ring in the top o-ring groove of the 102881 flow cell body.
4. Place the sensor body into the flow cell body, and tighten the 102586 nut until it is hand-tight.

Typical Installation

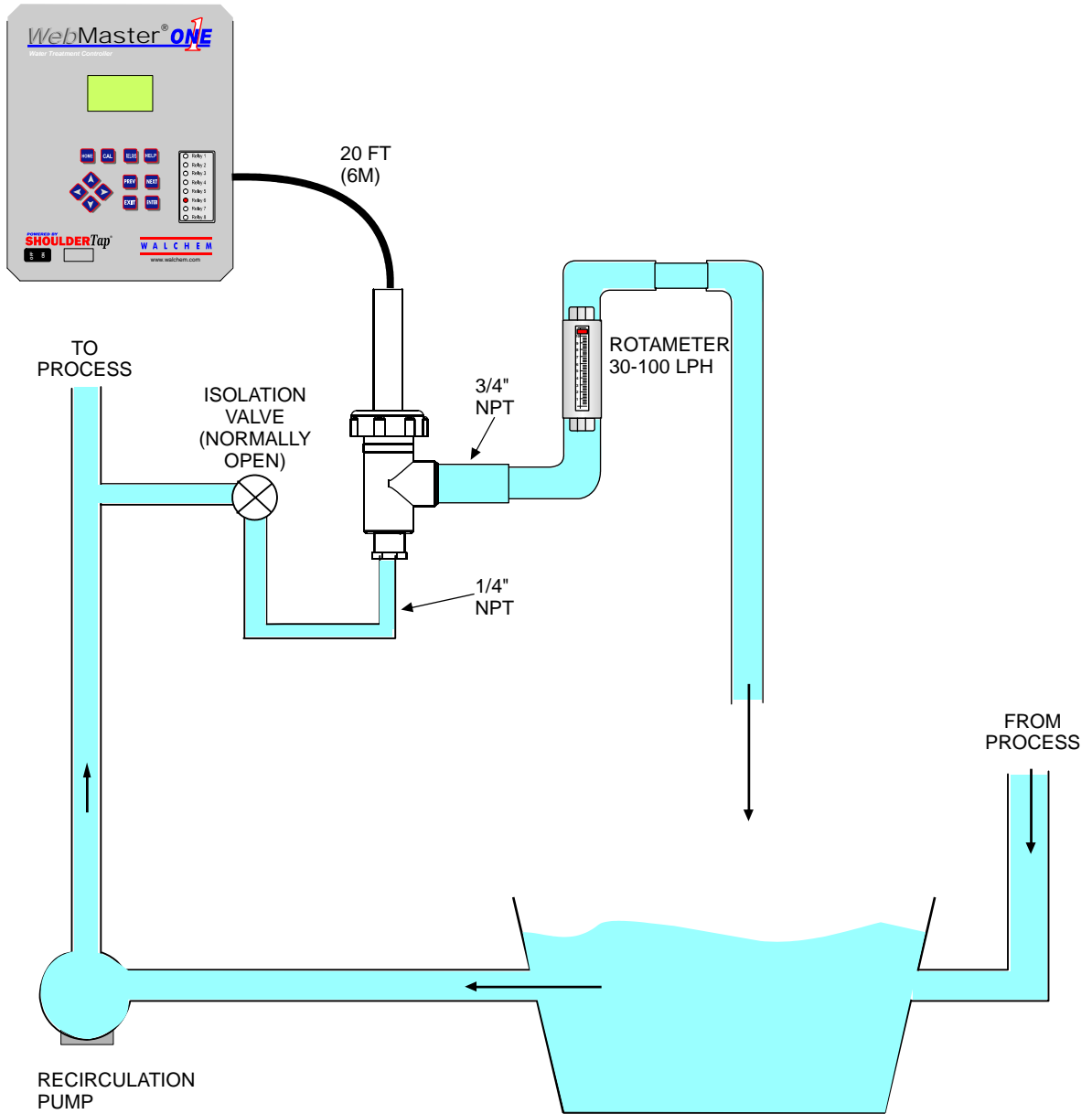

Typical Installation Using Walchem Flow Switch Manifold

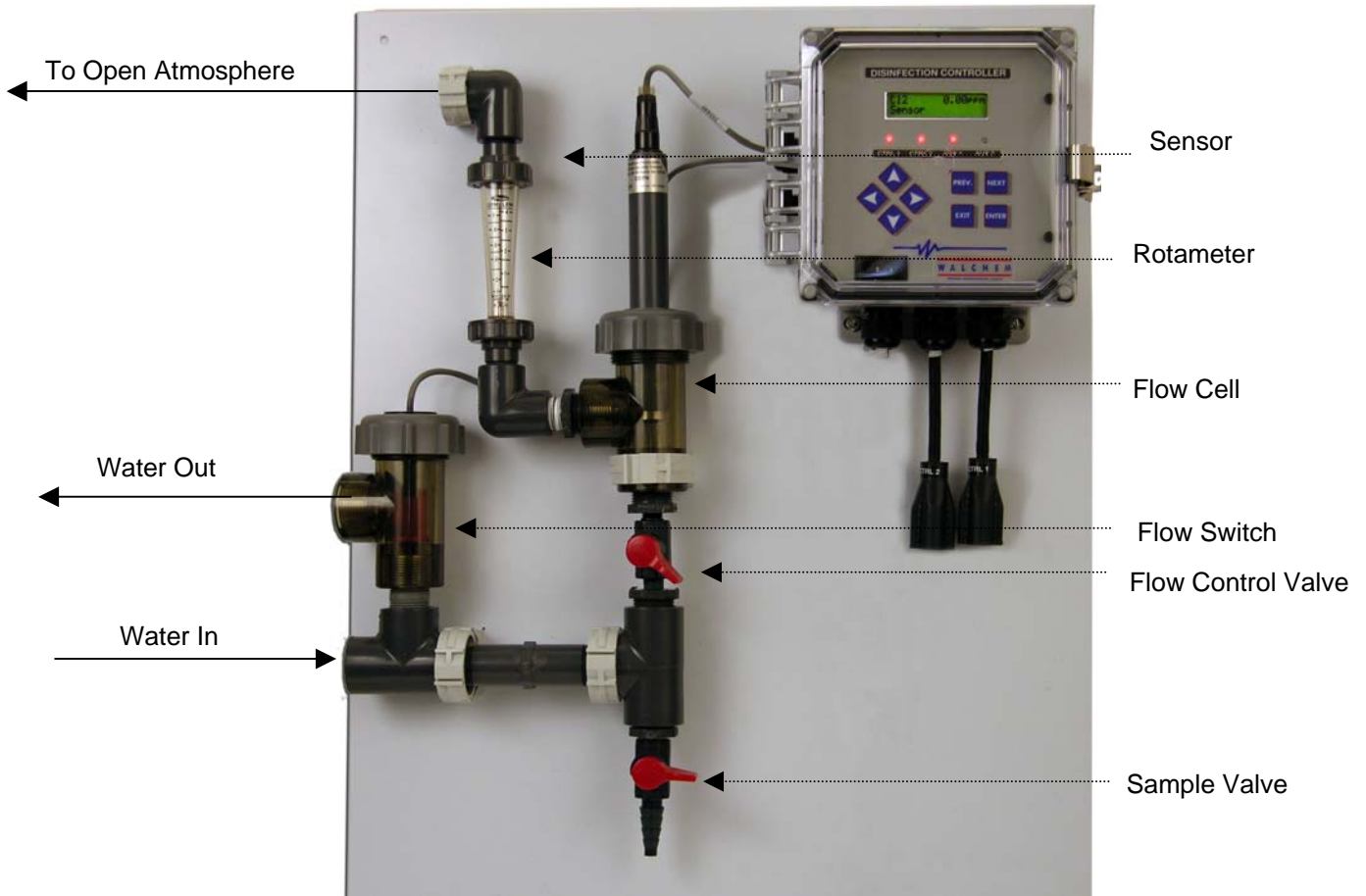

Sensor Parts Exploded View

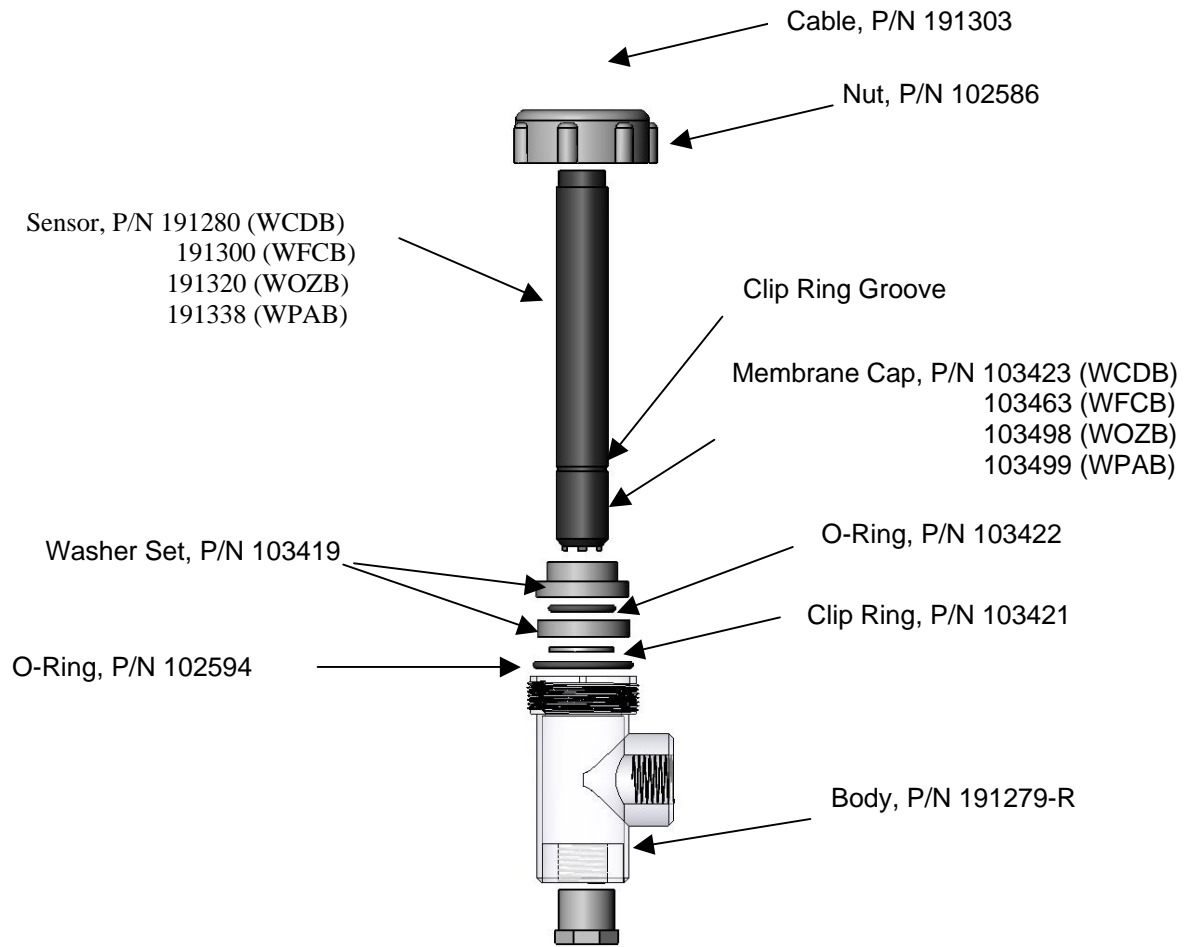

Wiring Instructions

WebMaster

The sensor is provided with a 2-twisted pair, shielded, 24 AWG, 35 pF/foot capacitance cable. The wiring to the controller is as follows:

Shield Drain:	Earth Ground
GRN :	IN+
WHT :	IN-
RED:	+5 VDC
BLK:	- 5 VDC

If the required cable length exceeds the 6 meters (20 feet) that is supplied, wire the housing to a 190851 terminal box, then use a p/n 100084 cable to reach the instrument. The maximum cable length is 305 meters (1000 feet).

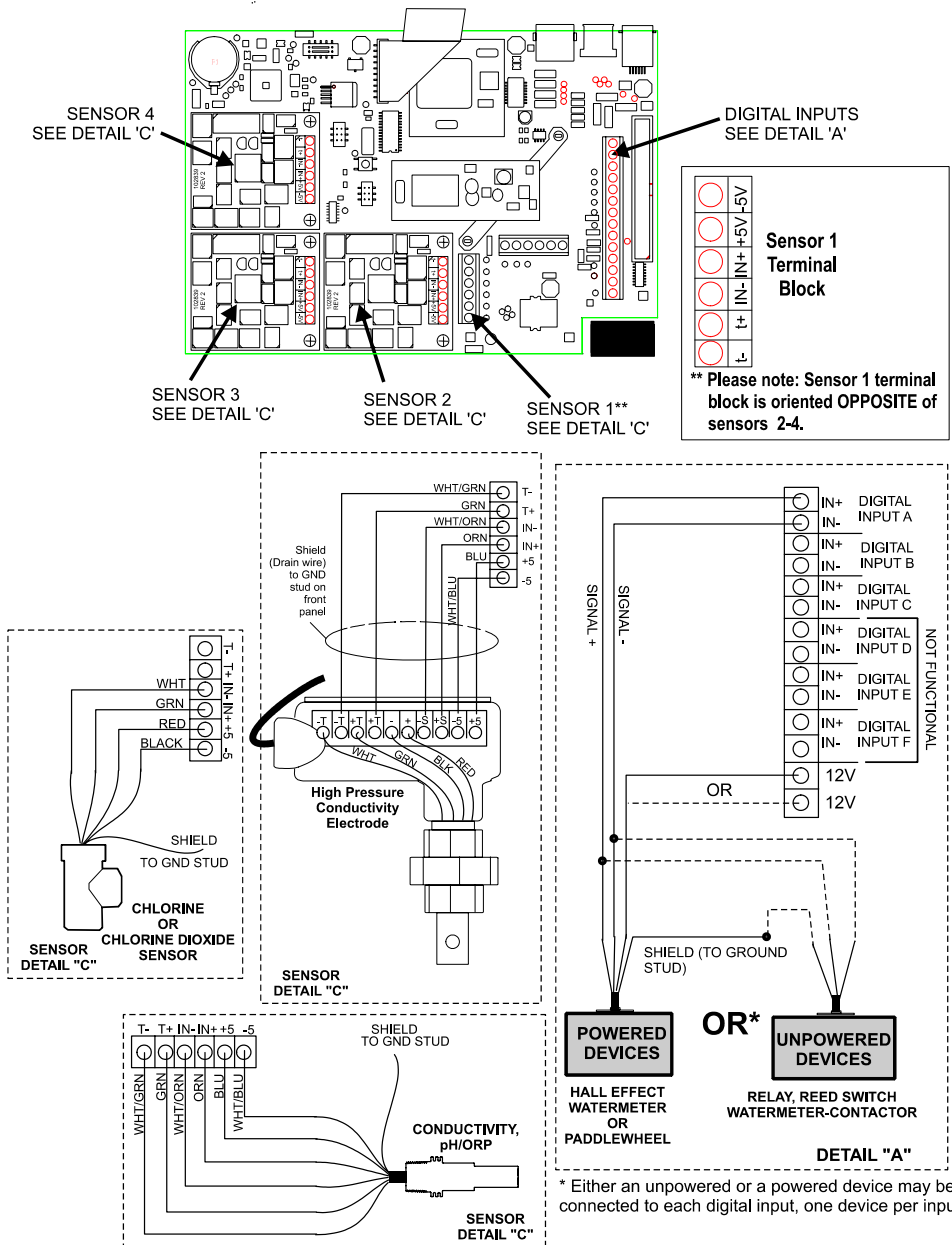

WDIS310

The sensor is provided with a 2-twisted pair, shielded, 24 AWG, 35 pF/foot capacitance cable. The wiring to the controller is as follows:

Shield Drain:	Earth Ground
GRN :	PH+
WHT :	COM
RED:	+5 VDC
BLK:	- 5 VDC

If the required cable length exceeds the 6 meters (20 feet) that is supplied, wire the housing to a 190851 terminal box, then use a p/n 100084 cable to reach the instrument. The maximum cable length is 305 meters (1000 feet).

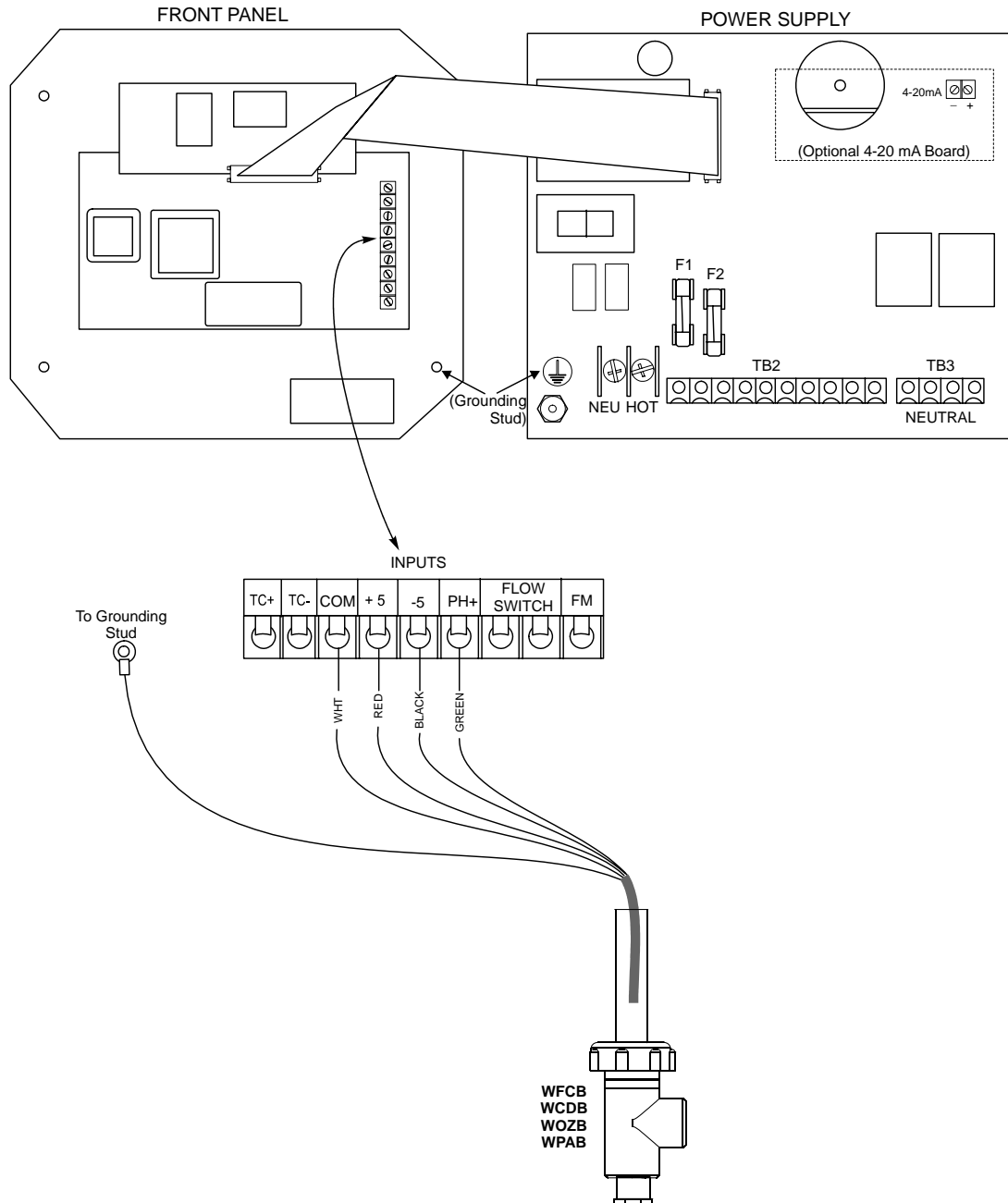

3.0 Operation

This section describes how to prepare the sensor for use.

Conditioning

The sensor requires conditioning to acclimate the electrodes prior to generating stable readings. Conditioning consists of installing the sensor in the flow cell, ensuring that the sensor remains wet at all times, and supplying power to the sensor.

The following conditioning times are recommended:

New Sensor	12 – 24 hours
After membrane or electrolyte replacement	1 hour

Calibration

The frequency of calibration is a function of many factors. These factors include:

1. The accuracy required by the application.
2. The value of the off-specification product versus the cost of calibration.
3. The coating or abrasive nature of the application.
4. The stability of the sensor and controller as a system.

The frequency of calibration is really determined by experience. At a new installation, calibration might initially be checked every day by comparing the controller reading to a DPD test or other manual analysis and logging the results. If the reading drifts off significantly in one direction you should consider calibrating. Resist the temptation to calibrate to correct for small errors that may be a result of normal variations in the test methods.

A calibration **MUST** be performed on initial installation, or after cleaning or replacing the membrane or electrolyte. A sensor installed in clean water can hold its calibration for several months.

DO NOT attempt to perform a calibration until the following conditions have been met:

1. The sensor has been conditioned as described above.
2. The sensor has equilibrated to the temperature of the water (for the zero calibration) or the sample (for the 1 point process calibration).

Zero Calibration

1. Remove the sensor from the flow cell and place it in a beaker of clean, oxidizer-free water.
2. Allow the sensor 15 minutes to equilibrate to the water temperature.
3. Go to the Zero Calibration menu of the controller. Refer to the controller instructions.
4. Stir the water with the sensor until the mV reading is stable for at least 5 minutes.
5. When the reading is stable, continue to the final steps of the calibration.
6. Return the sensor to the flow cell and check for leaks.

One Point Process Calibration

1. Ensure that the sensor is conditioned and equilibrated to the temperature of the sample.
2. Ensure that the sample flow rate is between 30 and 100 liters/hour.
3. Perform a DPD test or other manual analysis on the sample water.
4. Go to the One Point Process Calibration menu of the controller. Refer to the controller instructions.
5. When the reading is stable, continue to the final steps of the calibration.

NOTE: Disinfectant concentration can change rapidly in the sample! Minimize the time between performing the DPD test or manual analysis and finishing the calibration!

4.0 Troubleshooting

The disinfectant reading is much lower than the manual analysis

Possible Causes	Corrective Actions
Insufficient conditioning	Wait for the appropriate amount of time before attempting a calibration.
Insufficient sample flow	Increase flow rate to between 30 and 100 liter per hour.
Air bubbles on membrane	Dislodge bubbles. Adjust flow rate higher if necessary.
Dirty membrane	Clean membrane
Faulty membrane	Replace membrane cap.
High Pressure	Reduce pressure to below 1 atmosphere and refill cap with electrolyte
No electrolyte fill solution in membrane cap	Fill membrane cap with electrolyte. Replace membrane cap if it will not hold solution.
Faulty sensor	Replace sensor
Faulty analysis equipment or reagents	Consult test equipment instructions

The disinfectant reading is much higher than the manual analysis

Possible Causes	Corrective Actions
Insufficient conditioning	Wait for the appropriate amount of time before attempting a calibration.
Faulty membrane	Replace membrane cap.
Faulty sensor	Replace sensor
Faulty analysis equipment or reagents	Consult test equipment instructions
Ozone or chlorine in the water (ClO ₂ or O ₃ sensors)	Remove source of contamination
Bromine, Ozone, Iodine, ClO ₂ , Di-/Trichloramine, or Bromamine in the water (Cl ₂ sensor)	Remove source of contamination

Sensor Error

This error message appears if the signal from the sensor is outside the range of -1400 to 1400 mVDC.

Possible Causes	Corrective Actions
Faulty wiring	Check wiring
Faulty sensor	Replace sensor
Faulty controller sensor input	Go to the Sensor Input menu and perform a self test. If this passes, then the problem is with the sensor or its wiring. If it fails, then disconnect the sensor from the circuit board and try the self test again. If it still fails, replace the circuit board.

Disinfectant Reading is Unstable

Possible Causes	Corrective Actions
Air bubbles on membrane	Dislodge bubbles. Adjust flow rate higher if necessary.
Faulty membrane	Replace membrane cap.
Faulty wiring	Check wiring
Faulty controller sensor input	Go to the Sensor Input menu and perform a self test. If this passes, then the problem is with the sensor or its wiring. If it fails, then disconnect the sensor from the circuit board and try the self test again. If it still fails, replace the circuit board.

Calibration Failure

For WebMaster

The controller will display a calibration failure if the offset calculated in the Zero Calibration is outside of the range -20 to 40 mV or the slope calculated in the One Point Process Calibration is outside of the range -10 to -100 mV per ppm of ClO₂, Cl₂ and ozone, or -1 to -10 mV per ppm of PAA.

For WDIS:

The expected response is -100 mV/ppm for Cl₂, ClO₂, and Ozone, or -10 mV/ppm for Peracetic Acid. The acceptable range is for -100 mV (or -10 mV for PAA) to equal 0.5 to 2.0 ppm. The range of mV for a Zero Calibration is -100 mV to 100 mV.

Possible Causes	Corrective Actions
Insufficient conditioning	Wait for the appropriate amount of time before attempting a calibration.
Insufficient sample flow	Increase flow rate to between 30 and 100 liters per hour
Air bubbles on membrane	Dislodge bubbles. Adjust flow rate higher if necessary.
Dirty membrane	Clean membrane
Faulty membrane	Replace membrane cap.

High Pressure	Reduce pressure to below 1 atmosphere and refill cap with electrolyte
No electrolyte fill solution in membrane cap	Fill membrane cap with electrolyte. Replace membrane cap if it will not hold solution.
Faulty sensor	Replace sensor
Faulty analysis equipment or reagents	Consult test equipment instructions
Ozone or chlorine in the water	Remove source of contamination
Faulty wiring	Check wiring
Faulty controller sensor input	Go to the Sensor Input Page and perform a self test. If this passes, then the problem is with the sensor or its wiring. If it fails, then disconnect the sensor from the circuit board and try the self test again. If it still fails, replace the circuit board.

5.0 Maintenance

The sections below describe how to clean and replace the membrane cap and electrolyte solution, and also how to store the sensor when not in use.

See section 4.0 Troubleshooting for assistance in determining when maintenance may be required.

Cleaning the Membrane

Instructions for cleaning the membrane vary depending upon the type of contamination. Follow the directions for replacing the membrane shown below, replacing step 3 with one of these cleaning methods:

For general deposits:
Rinse in clear cold water.

For calcium scale:
Soak in dilute (1% by volume) hydrochloric acid, then rinse in clear cold water.

For oils:
Rinse in isopropyl alcohol.
DO NOT use cleaners or detergents containing surfactants, as these will reduce the life of the membrane.

If the sensor still cannot be calibrated after cleaning, replace the membrane cap as described below.

Replacing the Membrane



CAUTION: Wear gloves and safety glasses during assembly of the sensor since the electrolyte is a **STRONG ACID**. It is recommended to perform this operation over a sink with running water available. After using, re-cap any remaining electrolyte until the next use.

1. Hold the sensor vertically with the membrane facing down and carefully unscrew the membrane cap. Always move the gray bands to uncover the vent hole before removing the cap!
2. Rinse the electrolyte fill solution off the cap and electrodes with cold water.
3. Discard the old membrane cap.
4. Unpack the new membrane cap, taking care not to touch the membrane or get it dirty.
5. Fill the membrane cap to the top with the electrolyte fill solution.
6. Hold the sensor body vertically with the tip pointing down and **SLOWLY** screw on the membrane cap until it is hand tight. **Be prepared for some electrolyte solution to squeeze out from the cap**
7. Rinse your hands, the sensor, and all surfaces contaminated with electrolyte solution with running water.
8. Check the sensor for leaks, especially at the membrane and the membrane cap threads. If any leaks are detected, tighten the membrane cap or replace it.

Sensor Storage

The sensor may be stored for up to one month in the flow cell assuming that the membrane is always kept submerged in water.

For long term storage, follow this procedure:



CAUTION: Wear gloves and safety glasses during assembly of the sensor since the electrolyte is a **STRONG ACID**. It is recommended to perform this operation over a sink with running water available. After using, re-cap any remaining electrolyte until the next use.

1. Hold the sensor vertically with the membrane facing down and carefully unscrew the membrane cap. Always move the gray bands to uncover the vent hole before removing the cap!
2. Rinse the electrolyte fill solution off the cap and electrodes with cold water.
3. Allow the parts to air dry.
4. Loosely screw the membrane cap back on and store the sensor in a clean dry place.

5.0 Specifications

	Chlorine Dioxide	Peracetic Acid	Ozone	Chlorine
Measurement Performance				
Range	0-10 mg/l	0-1000 mg/l	0-10 mg/l	0-10 mg/l
Resolution	0.01 mg/l	1 mg/l	0.01 mg/l	0.01 mg/l
Cross Sensitivity	Free Chlorine (5%), Ozone		Free Chlorine (5%)	Bromine, Ozone, Iodine, ClO ₂ , Di-/Trichloramine, or Bromamine
Flow Rate of Sample	30 to 100 liters/hour (0.13 to 0.44 gallons/minute)			
pH Range of Sample	1.0 – 14.0			6.8 – 8.0 (7.2 to 7.4 ideal)
Conductivity Range of Sample	50 to 10,000 µS/cm			
Response Time	30 sec	3 min	30 sec	30 sec
Electrical				
Power Requirements	± 5 VDC, 5 mA maximum			
Signal	0 to -1000 mVDC			
Maximum Cable Length	305 m (1000 ft)			
Cable Required	2 twisted pair, 24 AWG, shielded			
Mechanical				
	Chlorine Dioxide	Peracetic Acid	Ozone	Chlorine
Operating Temperature	0 to 50°C (41 to 122°F)			0 to 45°C (41 to 113°F)
Operating Pressure	0 to 1 atm (0 to 14.7 psi)			
Storage Temperature	0 to 50°C (41 to 122°F)			

Shelf Life	1 year	
Flow Cell Inlet	¼" NPTF	
Flow Cell Outlet	¾" NPTF	
<i>Wetted Materials of Construction</i>		
Sensor Body	PVC, Polycarbonate	
Membrane	Silicone	PTFE
Flow Cell Body	Isoplast	
O-Ring	FKM	