

WDIS Series
Disinfection Controller
Instruction Manual

Notice

©2007 WALCHEM Corporation
5 Boynton Road, Holliston, MA 01746 USA
(508) 429-1110
All Rights Reserved
Printed in USA

Proprietary Material

The information and descriptions contained herein are the property of WALCHEM Corporation. Such information and descriptions may not be copied or reproduced by any means, or disseminated or distributed without the express prior written permission of WALCHEM Corporation, 5 Boynton Road, Holliston, MA 01746.

This document is for information purposes only and is subject to change without notice.

Statement of Limited Warranty

WALCHEM Corporation warrants equipment of its manufacture, and bearing its identification to be free from defects in workmanship and material for a period of 24 months for electronics and 12 months for mechanical parts and electrodes from date of delivery from the factory or authorized distributor under normal use and service and otherwise when such equipment is used in accordance with instructions furnished by WALCHEM Corporation and for the purposes disclosed in writing at the time of purchase, if any. WALCHEM Corporation's liability under this warranty shall be limited to replacement or repair, F.O.B. Holliston, MA U.S.A. of any defective equipment or part which, having been returned to WALCHEM Corporation, transportation charges prepaid, has been inspected and determined by WALCHEM Corporation to be defective. Replaceable elastomeric parts and glass components are expendable and are not covered by any warranty.

THIS WARRANTY IS IN LIEU OF ANY OTHER WARRANTY, EITHER EXPRESS OR IMPLIED, AS TO DESCRIPTION, QUALITY, MERCHANTABILITY, FITNESS FOR ANY PARTICULAR PURPOSE OR USE, OR ANY OTHER MATTER.

P/N 180318.C1
Oct 2007

Table of Contents

1.0	Introduction.....	1
2.0	Specifications	1
2.1	Measurement Performance (Sensors)	1
2.2	Electrical: Input/Output.....	2
	Input Power.....	2
	Input Signal.....	2
	Output.....	2
	Agency Approvals.....	3
2.3	Mechanical.....	3
	Controller.....	3
3.0	Unpacking and Installation.....	3
3.1	Unpacking the unit.....	3
3.2	Mounting the electronic enclosure.....	3
3.3	Installation.....	4
	Assembling the Sensor.....	4
	Flow Cell Placement.....	4
	Installing Sensor into Flow Cell.....	5
3.4	Icon Definitions.....	6
3.5	Electrical Installation.....	9
4.0	Function Overview	13
4.1	Front Panel.....	13
4.2	Display.....	13
4.3	Keypad.....	14
4.4	Access Code.....	14
4.5	Startup.....	14
	Initial Startup.....	14
	Normal Startup.....	14
4.6	Shutdown.....	15
5.0	Operation.....	15
5.1	Main Menu.....	15
5.2	Sensor Menu.....	17
	Cal'd.....	17
	Calibration.....	17
	Zero Calibration.....	17
	Days Btwn Cal.....	17
	Input.....	19
	Self Test.....	19
	Sensor Type.....	19
5.3	Control 1 and Control 2 Menus.....	19
	Hi/Lo Set Point.....	19
	Dead Band.....	19
	Time Limit.....	19
	Interlock.....	19
	Control Dir.....	20
	HOA.....	20
5.4	Auxiliary 1 and 2 Menu.....	22
	Mode.....	22
	Lo Alarm Pt.....	22
	Hi Alarm Pt.....	22
	Dead Band.....	22
	Probe Wash Sched.....	23
	Hold Time.....	23
	HOA.....	23
5.5	4-20 mA Menu (Optional).....	25
	4 mA Pt.....	25
	20 mA Pt.....	25
	Calibrate.....	25
	Fixed 4 mA Out.....	25

	Fixed 20 mA Out	25
5.6	Clock Menu	26
	Set Clock	26
5.7	Access Code Menu	27
	Enable Y/N.....	27
	New Access Code.....	27
6.0	Maintenance	29
6.1	Sensor Maintenance	29
	Cleaning the Membrane.....	29
	Replacing the Membrane.....	29
6.2	Replacing the Fuses	30
7.0	Troubleshooting	30
7.1	Error Messages.....	30
	Calibration Time.....	30
	Cal Failed.....	30
	Sens Low No Cal	30
	Probe Error No Cal	30
	Bad Zero Cal Fail	31
	Output Timeout	31
	High Alarm	31
	Low Alarm	32
	Out Range Alarm	32
	In Range Output.....	32
	Probe Error	32
	Interlock	32
	Check Set Points	33
8.0	Service Policy	33

1.0 Introduction

The Walchem WDIS Series controllers are wall mount disinfection controllers that provide two relays used to perform on/off control of chlorine, chlorine dioxide, ozone or Peracetic acid. Two additional relays are available for use as alarms or probe washing. A fifth output is used as a diagnostic alarm. An isolated 4-20 mA output is optional.

They are only compatible with Walchem sensors. The choice of the type of sensor is selected through the keypad. The sensors are temperature compensated internally; no temperature signal is transmitted to the controller. The controller will prompt you to calibrate the sensor at the desired frequency.

2.0 Specifications

2.1 Measurement Performance (Sensors)

	Chlorine Dioxide	Peracetic Acid	Ozone	Chlorine
Measurement Performance				
Range	0-10 mg/l	0-1000 mg/l	0-10 mg/l	0-10 mg/l
Resolution	0.01 mg/l	1 mg/l	0.01 mg/l	0.01 mg/l
Cross Sensitivity	Free Chlorine (5%), Ozone		Free Chlorine (5%)	Bromine, Ozone, Iodine, ClO ₂ , Di-/Trichloramine, or Bromamine
Flow Rate of Sample	30 to 100 liters/hour (0.13 to 0.44 gallons/minute)			
pH Range of Sample	1.0 – 14.0		6.8 – 8.0 (7.2 to 7.4 ideal)	
Conductivity Range of Sample	50 to 10,000 µS/cm			
Response Time	30 sec	3 min	30 sec	30 sec
Electrical				
Power Requirements	± 5 VDC, 5 mA maximum			
Signal	0 to -1000 mVDC			
Maximum Cable Length	1000 ft (305 m)			
Cable Required	2 twisted pair, 24 AWG, shielded, 15 pF/ft			

Mechanical				
	Chlorine Dioxide	Peracetic Acid	Ozone	Chlorine
Operating Temperature	0 to 50°C (41 to 122°F)			0 to 45°C (41 to 113° F)
Operating Pressure	0 to 1 atm (0 to 14.7 psi)			
Storage Temperature	0 to 50°C (41 to 122°F)			
Shelf Life	1 year			
Flow Cell Inlet	¼” NPTF			
Flow Cell Outlet	¾” NPTF			
Wetted Materials of Construction				
Sensor Body	PVC, Polycarbonate			
Membrane	Silicone			PTFE
Flow Cell Body	Isoplast			
O-Ring	FKM			

2.2 Electrical: Input/Output

Input Power

Controller	110-120VAC	or	220-240VAC
	50/60 Hz, 10A	or	50/60 Hz, 5A

Input Signal

Controller Sensor Input	±1400 mV
Interlock (optional)	Isolated dry contact closure required (i.e., flow, level, etc.)

Output

Control 1/2 (ON/OFF)	
Internally powered relays	@ 120 VAC, 10A resistive, 1/8 HP
	@ 240 VAC, 6A resistive, 1/8 HP

AUX1, AUX2, Alarm	
Dry contact relays	@ 120 VAC, 10A resistive, 1/8 HP
	@ 240 VAC, 6A resistive, 1/8 HP

Note: The Alarm relay is non-programmable. Refer to the Main Menu diagram on page 14 for the list of error conditions that trigger the alarm relay.

4-20 mA (optional)	Fully isolated, internally powered, 600 Ω max. resistive load. Resolution .001% of span, accuracy ±1% of reading.
--------------------	---

Sensor Power (supplied by controller)	±5 VDC, 5 mA
--	--------------

Agency Approvals

UL	ANSI/UL 61010-1:2004, 2 nd Edition*
CAN/CSA	C22,2 No.61010-1:2004 2 nd Edition*
CE Safety	EN 61010-1 2 nd Edition (2001)*
CE EMC	EN 61326 :1998 Annex A*

Note: For EN61000-4-6,-3 the controller met performance criteria B.

*Class A equipment: Equipment suitable for use in establishments other than domestic, and those directly connected to a low voltage (100-240 VAC) power supply network which supplies buildings used for domestic purposes.

2.3 Mechanical

Controller

Enclosure:	Polycarbonate
NEMA Rating:	NEMA 4X
Dimensions:	8.5" x 6.5" x 5.5"
Display:	2 x 16 character backlit liquid crystal
Operating Ambient Temp:	32 - 122°F (0 - 50°C)
Storage Temperature:	-20 to 180°F (-29 to 80°C)
Shipping Weight:	7 lbs (3kg) (approximately)

3.0 Unpacking and Installation

3.1 Unpacking the unit

Inspect the contents of the carton. Please notify the carrier immediately if there are any signs of damage to the controller or its parts. Contact your distributor if any of the parts are missing. The carton should contain a WDIS controller and instruction manual. Any options or accessories will be incorporated as ordered.

3.2 Mounting the electronic enclosure

The WDIS series controller is supplied with mounting holes on the enclosure. It should be wall mounted with the display at eye level, on a vibration-free surface, utilizing all 4 mounting holes for maximum stability. Use M6 (1/4" diameter) fasteners that are appropriate for the substrate material of the wall. The enclosure is NEMA 4X rated. The maximum operating ambient temperature is 122°F (50°C). The enclosure requires the following clearances:

Top:	2"
Left:	8"
Right:	4"
Bottom:	7"

3.3 Installation

Once the enclosure is mounted, the metering pumps may be located at any distance from the controller. The sensor may be placed up to 1000 feet (305m) from the controller. Shielded cable with twisted pairs is required. Always route AC voltage wiring in conduit that is separated by 6 inches from low voltage DC signal lines (such as the sensor signal).

Assembling the Sensor



CAUTION: Wear gloves and safety glasses during assembly of the sensor since the electrolyte is a **STRONG ACID**. It is recommended to perform this operation over a sink with running water available. After using, re-cap any remaining electrolyte until the next use.

1. Remove the black protective tube from the electrode tip, and clean just the **tip** of the working electrode with the special abrasive paper supplied. Avoid touching the electrodes! Hold the pad with the special abrasive paper and rub the electrode tip over it, holding the electrode at a slight angle. Repeat several times at different angles.
2. Open the vial containing the membrane cap. Empty out the water. Make sure that only one gray band is in the groove covering the vent hole in the membrane cap. Fill the membrane cap to the top with the electrolyte fill solution. (The free chlorine membrane cap is shipped dry, and has only one band)
3. Hold the sensor body vertically with the tip pointing down and **SLOWLY** screw on the membrane cap until it is hand tight. **Be prepared for some electrolyte solution to squeeze out from the vent hole in the cap.**
4. Push the second gray band into the groove in the cap, making sure that the bands are smooth and flush.
5. Rinse your hands, the sensor, and all surfaces contaminated with electrolyte solution with running water. Check the sensor for leaks, especially at the membrane and the membrane cap threads. If any leaks are detected, tighten the membrane cap or replace it.
6. Push the cable onto the end of the sensor, aligning the pins with the holes. Turn the connector until hand tight to seal the cable connection.

Flow Cell Placement

Instructions for mounting the sensor into the process can vary greatly with the circumstances that are encountered in your application. Here are some general guidelines to assist you. Refer also to the typical installation drawings.

The sensor should be mounted such that the measuring surfaces will always stay wet. If the membrane dries out, it will respond slowly to changing disinfectant values for 24 hours, and if dried out repeatedly, will fail prematurely.

The flow cell should be placed on the discharge side of a circulation pump or downhill from a gravity feed. Flow into the cell must come from the bottom side that has the $\frac{3}{4}$ " x $\frac{1}{4}$ " NPT reducing bushing installed. **The reducing bushing provides the flow velocity required for accurate readings and must not be removed!**

A "U" trap should be installed so that if the flow stops, the sensor is still immersed in the water. The outlet of the flow cell must be plumbed to open atmosphere unless the system pressure is at or below 1 atmosphere. If the flow through the line cannot be stopped to allow for cleaning and calibration of the sensor, then it should be placed in a by-pass line with

isolation valves to allow for sensor removal. Install the sensor vertically, with the measuring surface pointing down, at least 5 degrees above horizontal. (Refer to Installation drawings)

Flow rate regulation must be done upstream from the sensor, because any flow restriction downstream can increase the pressure above atmospheric and damage the membrane cap!



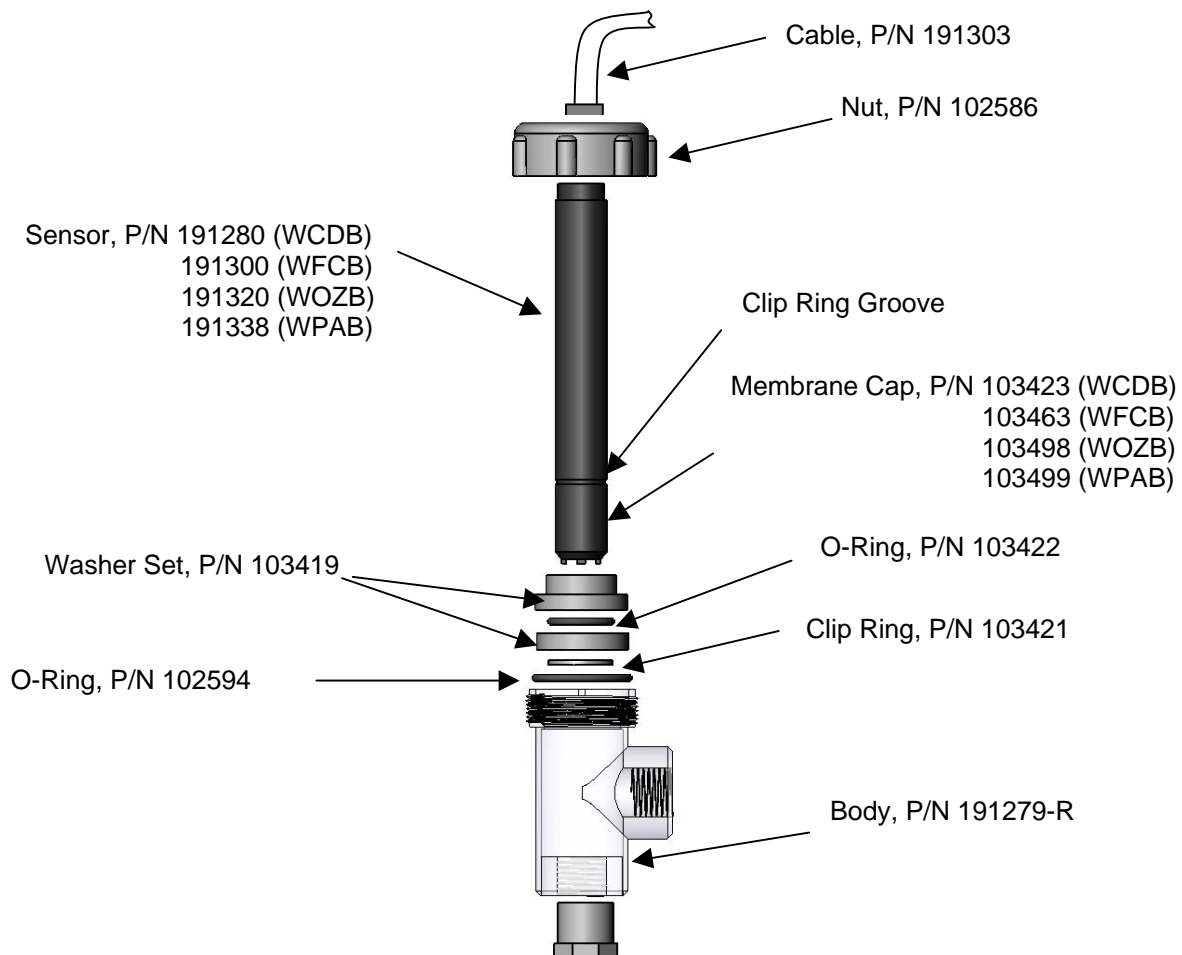

The sensor should be installed in an area where there is good solution movement and where it will respond rapidly to chemical additions. The placement of the sensor relative to the placement of chemical replenishment, along with the quality of the mixing, and the replenishment chemical flow rate are critical to accurate process control.

Installing Sensor into Flow Cell

1. Assemble the flow cell as shown below from the top down. The reducer should already be installed in the flow cell body.
2. Slide the 102586 nut over the membrane end of the sensor, followed by the 103419 top washer, followed by the 103422 o-ring, followed by the 103419 bottom washer, followed by the 103421 clip ring. The clip ring must be pushed up until it snaps into the groove in the sensor body.
3. Place the 102594 o-ring in the top o-ring groove of the 102881 flow cell body.
4. Place the sensor body into the flow cell body, and tighten the 102586 nut until it is hand-tight.
5. Insert the 191303 cable into the connector at the top of the sensor. The connector is keyed and will only insert in one orientation.



3.4 Icon Definitions

Symbol	Publication	Description
	IEC 417, No.5019	Protective Conductor Terminal
	IEC 417, No. 5007	On (Supply)
	IEC 417, No. 5008	Off (Supply)
	ISO 3864, No. B.3.6	Caution, risk of electric shock
	ISO 3864, No. B.3.1	Caution

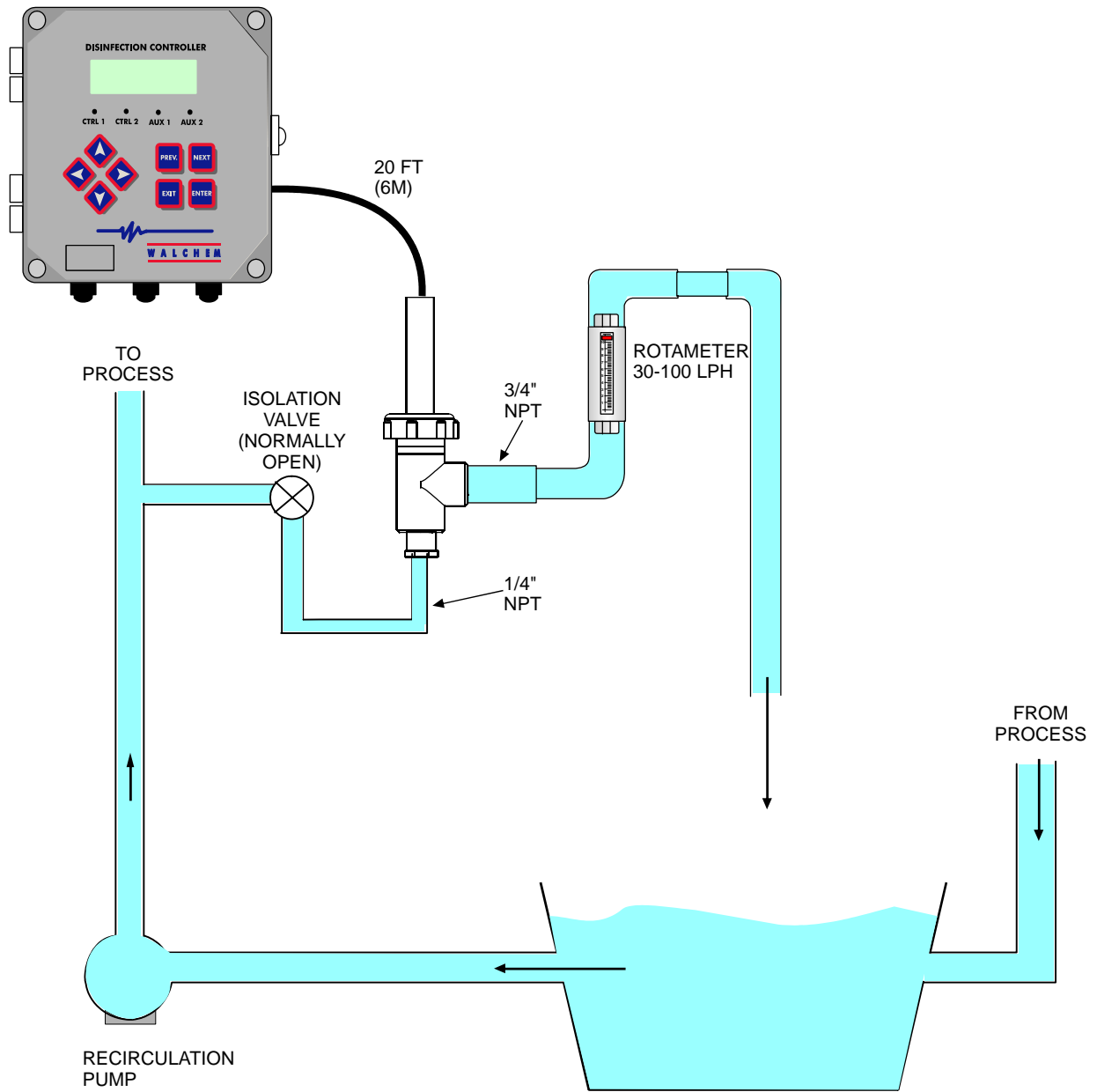
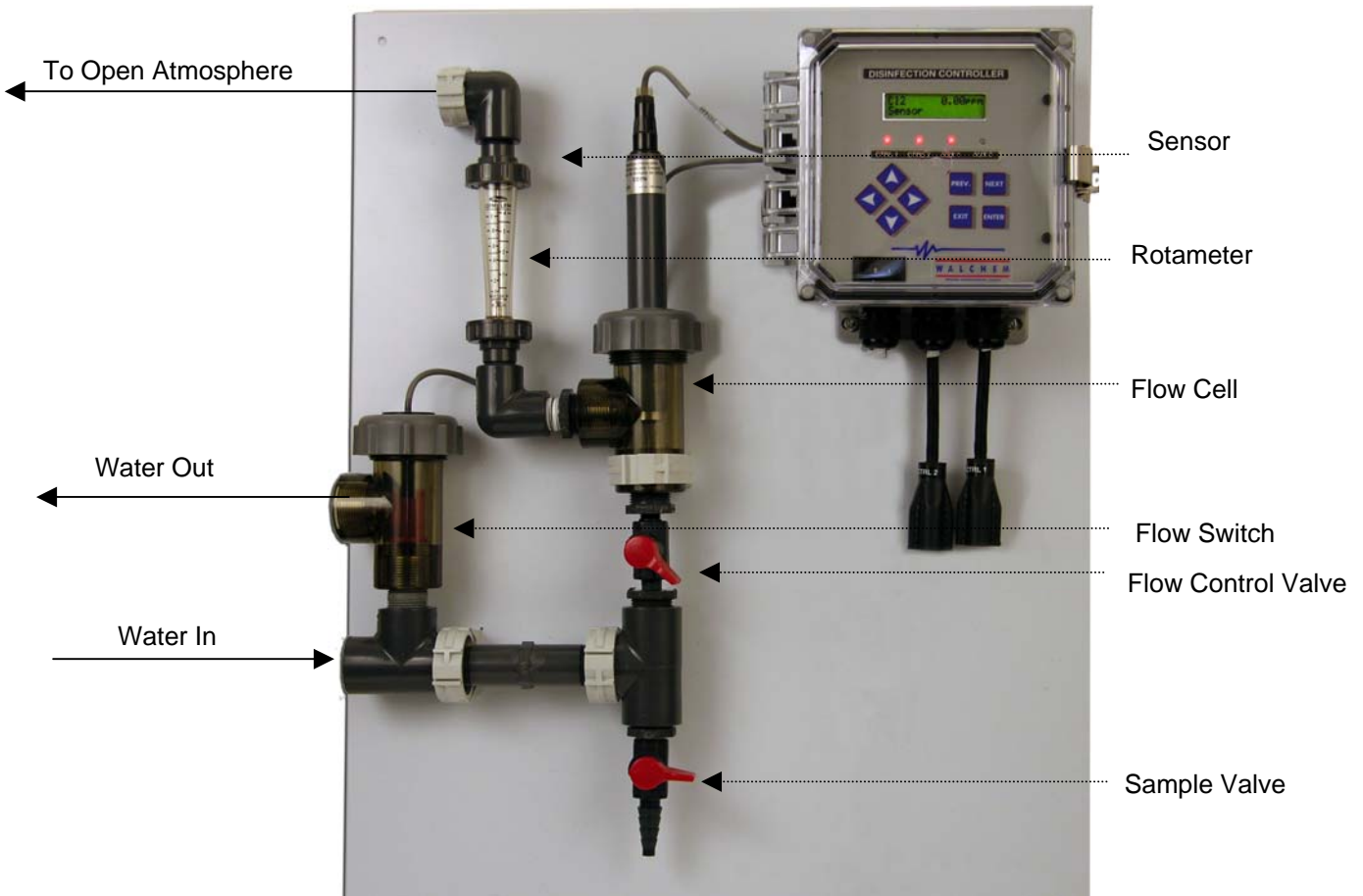

Figure 1 Typical Installation



Typical Installation Using Walchem Manifold

3.5 Electrical Installation

Based on the model number, the following voltages are required:

WDIS3xx-1xx	120 VAC, 50/60 Hz, prewired
WDIS3xx-4xx	120 VAC, 50/60 Hz, hardwired
WDIS3xx-5xx	240 VAC, 50/60 Hz, hardwired

The various standard wiring options are shown below. Your WDIS series controller will arrive from the factory prewired or ready for hardwiring. Depending on your configuration of controller options, you may be required to hardwire some or all of the output devices. Refer to figures 2, 3 and 4 for circuit board layout and wiring.

Note: When wiring the optional 4-20 mA output or a remote flow switch, it is advisable to use stranded, shielded, twisted pair wire between 22-26 AWG. Shield should be terminated at the controller ground stud (see figure 4).



CAUTION! There are live circuits inside the controller even when the power switch on the front panel is in the OFF position! The front panel must never be opened before power to the controller is REMOVED!

If your controller is prewired, it is supplied with a 8 foot, 18 AWG power cord with USA style plug. A tool (#1 phillips driver) is required to open the front panel.



CAUTION! When mounting the controller, make sure there is clear access to the disconnecting device!



CAUTION! The electrical installation of the controller must be done by trained personnel only and conform to all applicable National, State and Local codes!



CAUTION! Proper grounding of this product is required. Any attempt to bypass the grounding will compromise the safety of persons and property.



CAUTION! Operating this product in a manner not specified by Walchem may impair the protection provided by the equipment.

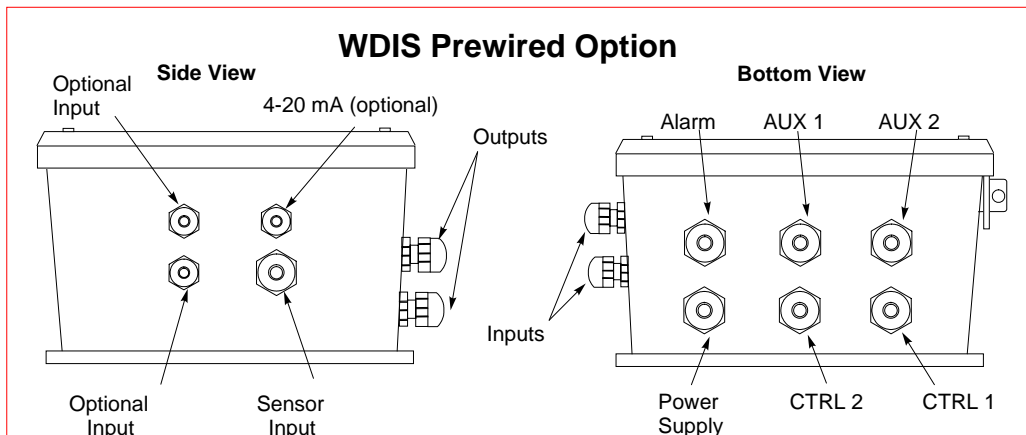
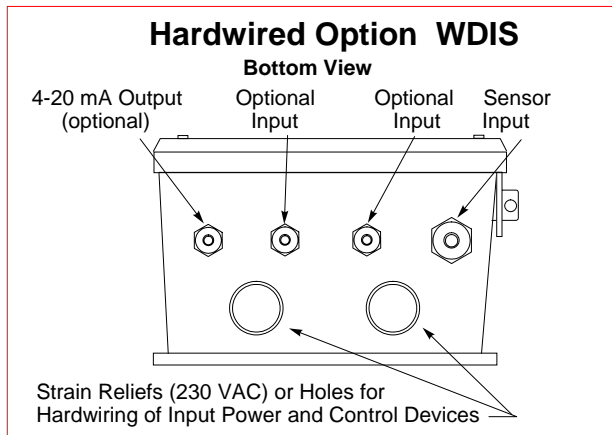

Figure 2 Conduit/Wiring Options

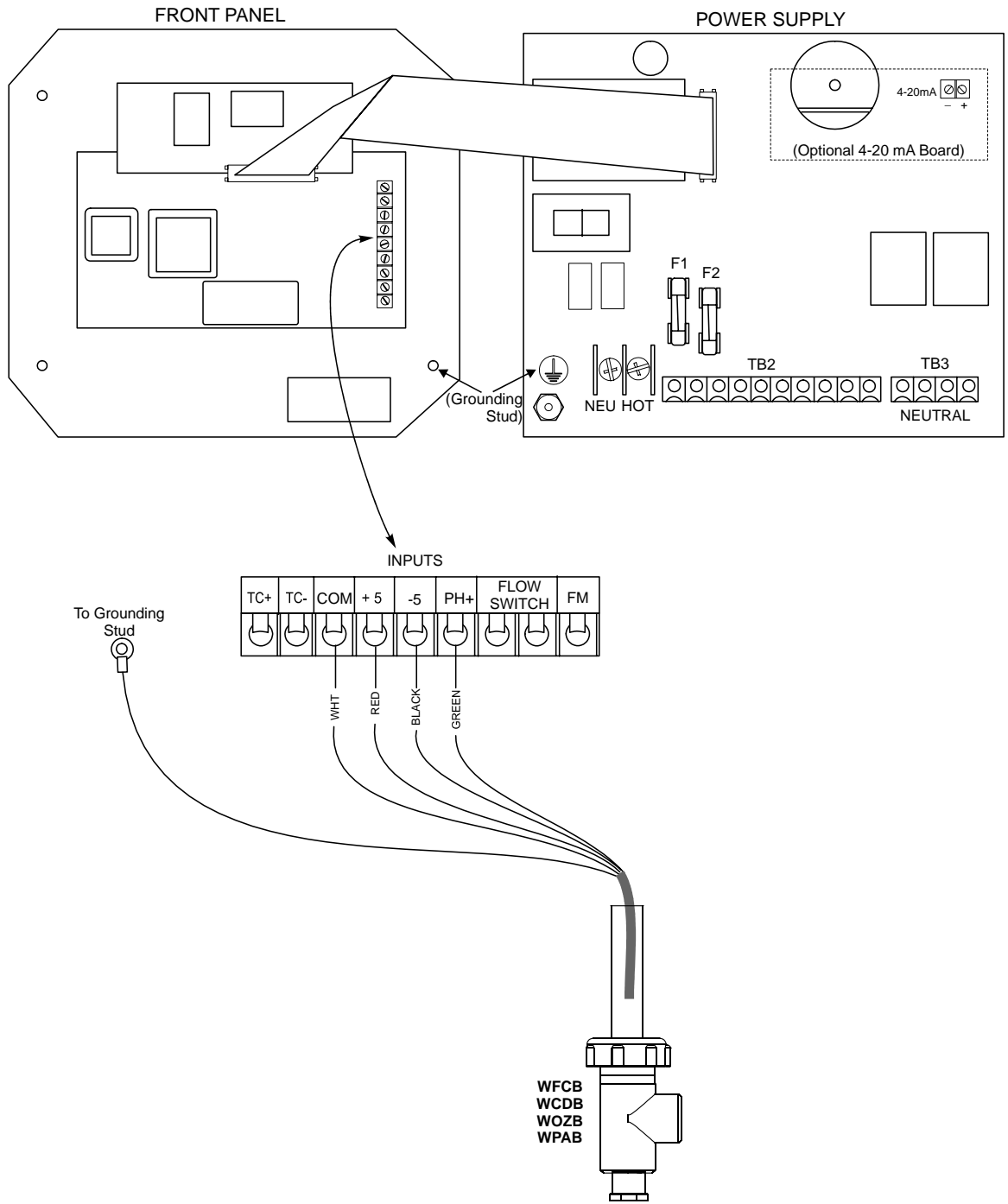

Figure 3 Wiring to Sensor

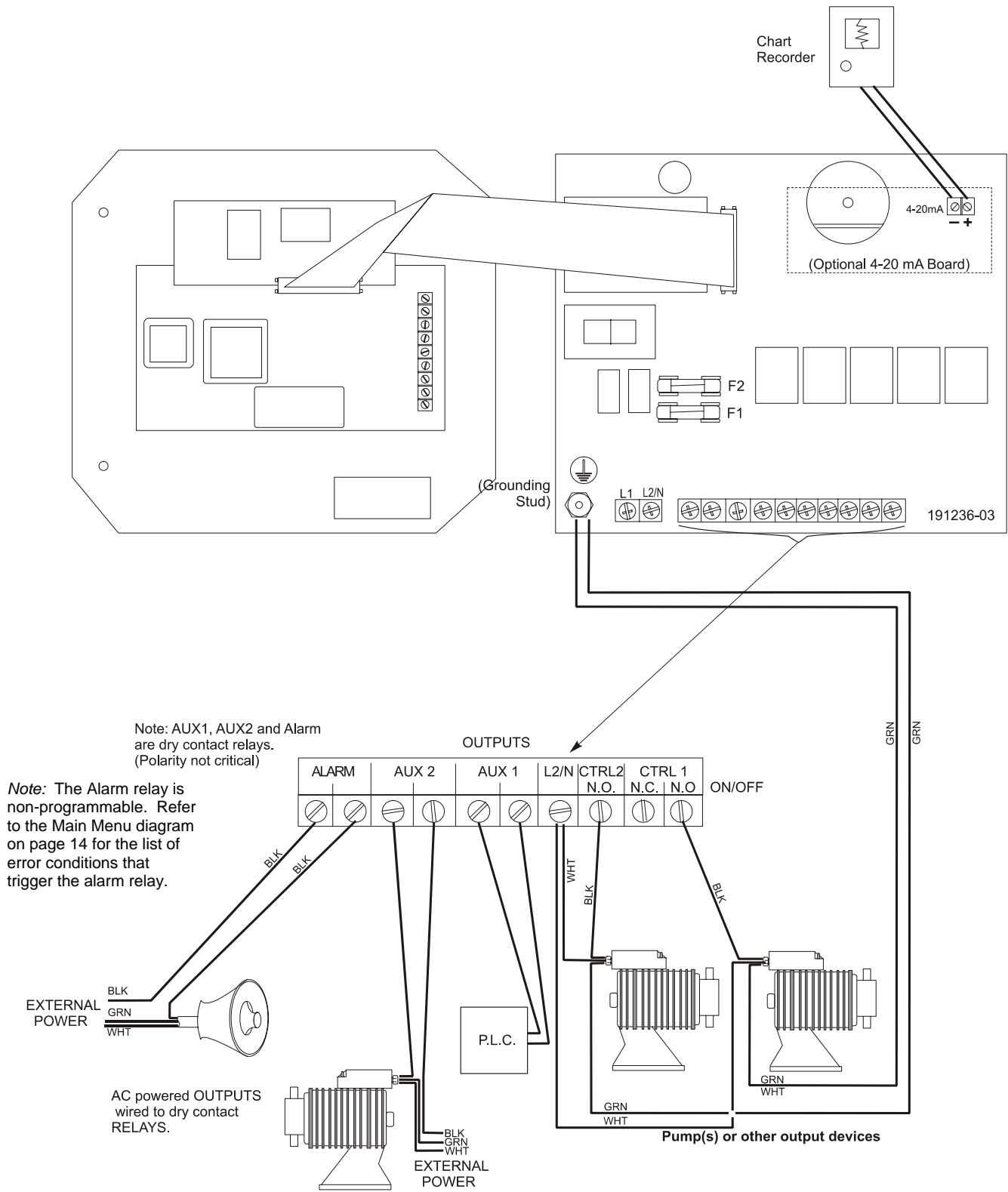
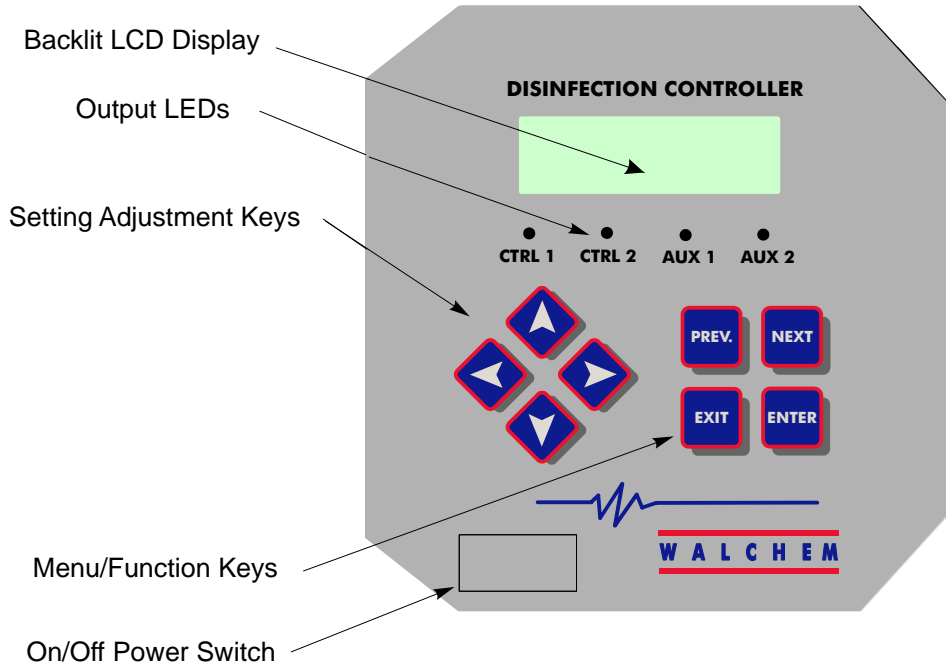

Figure 4 WDIS310 Output Wiring

4.0 Function Overview

4.1 Front Panel



4.2 Display

A summary screen is displayed while the WDIS controller is on. This display shows a bar graph of the oxidizer process value relative to the set points, a digital display of the process value, and the current operating conditions.

Towards the center of the bar graph are the (S)'s, which represent the set points. The bar graph grows from the left hand side, and the point furthest to the right indicates where the process value is relative to the set points.

The bottom line of the summary screen displays the following potential status messages: Probe Error, Calibration Time, Output Timeout, High/Low Alarm, Range Alarm, In Range Output, Output1 On, Output2 On, Probe Wash, Probe Wash Hold, Normal and Interlock.

Summary Screen



4.3 Keypad

The keypad consists of 4 directional arrows and 4 function keys. The arrow keys are used to move the adjustment cursor and change settings, while the function keys are used to enter values, and navigate the various menu screens. The function keys are **ENTER**, **EXIT**, **NEXT** and **PREV** (previous). Use the **NEXT** and **PREV** keys to scroll through the various menu choices. **ENTER** is used to enter a submenu and to enter a value. **EXIT** is used to back up one menu level. If you are at the main menu level, **EXIT** will return you to the summary screen.

To change a value in a submenu, the left/right arrow keys move the cursor left and right to each digit or option that can be changed. The up/down arrows will change numeric values up or down, or scroll through option choices. Press **ENTER** only when you have finished making ALL of the changes for that menu screen.

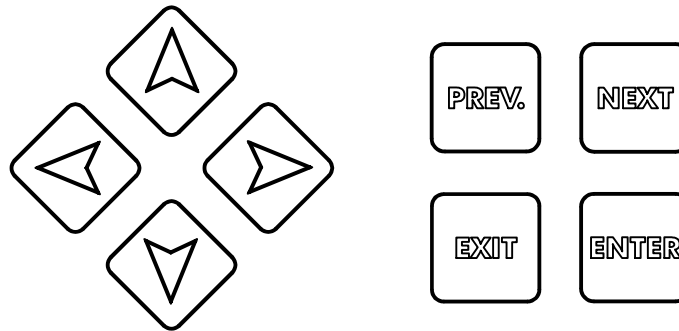

4.4 Access Code

The WDIS series controller is shipped with the access code disabled. If you wish to enable it, see Section 5.10 for operation. With the access code enabled, any user can view parameter settings, but not change them. Note that this provides protection only against casual tampering. Use a lock on the cover latch if you need more protection.

4.5 Startup

Initial Startup

After having mounted the enclosure and wired the unit, the controller is ready to be started.

Plug in the controller and turn "ON" the power switch to supply power to the unit. The display will briefly show the WDIS model number and then revert to the normal summary screen. Scroll through the menus and calibrate the sensor, and set the control parameters as detailed in Section 5, Operation.

To return to the summary screen, press the **EXIT** key until you return to this screen. The controller will automatically return to this screen after 10 minutes.

Normal Startup

Startup is a simple process once your set points are in memory. Simply check your supply of chemicals, turn on the controller, calibrate the sensor if necessary and it will start controlling.

4.6 Shutdown

To shut the WDIS controller down, simply turn off the power switch. Programming remains in memory.

The sensor must be stored with the measuring surfaces wet. If an extended shutdown will result in the sensor dehydrating, it must be removed from its position in the process and stored in a clean, dry place, without electrolyte in the cap. To reinstall, follow the directions in section 3.3.

5.0 Operation ---

These units control continuously while power is applied. Programming is accomplished via the local keypad and display.

To view the top level menu, press any key. The menu structure is grouped by inputs and outputs. Each input has its own setup menu for calibration and unit of measure selection as needed. Each output has its own setup menu including set points, timer values, direction of control, etc. as needed. After 10 minutes of inactivity in the menu, the display will return to the summary screen. Keep in mind that even while browsing through the menus, the unit is still controlling.

5.1 Main Menu

The exact configuration of your WDIS controller determines which menus are available as you scroll through the settings. Certain menus are only available if you select certain options. All settings are grouped under the following main menu items:

- Sensor
- Control 1
- Control 2
- Auxiliary 1
- Auxiliary 2
- 4-20 mA (Only if 4-20 mA option circuit board is installed)
- Time
- Access Code

The **NEXT** key travels forward through this list while the **PREV** key travels backwards through the list. Pressing **ENTER** will enter the lower level menu that is currently displayed.

Main Menu

Possible Status Screens

- * Probe Error
- Probe Wash
- Probe Wash Hold
- * Interlock
- * Output Timeout
- * Calibration Time
- Range Alarm
- In Range Output
- High/Low Alarm
- Output 1 On
- Output 2 On
- Normal

* These status screens indicate that the diagnostic alarm relay is activated.

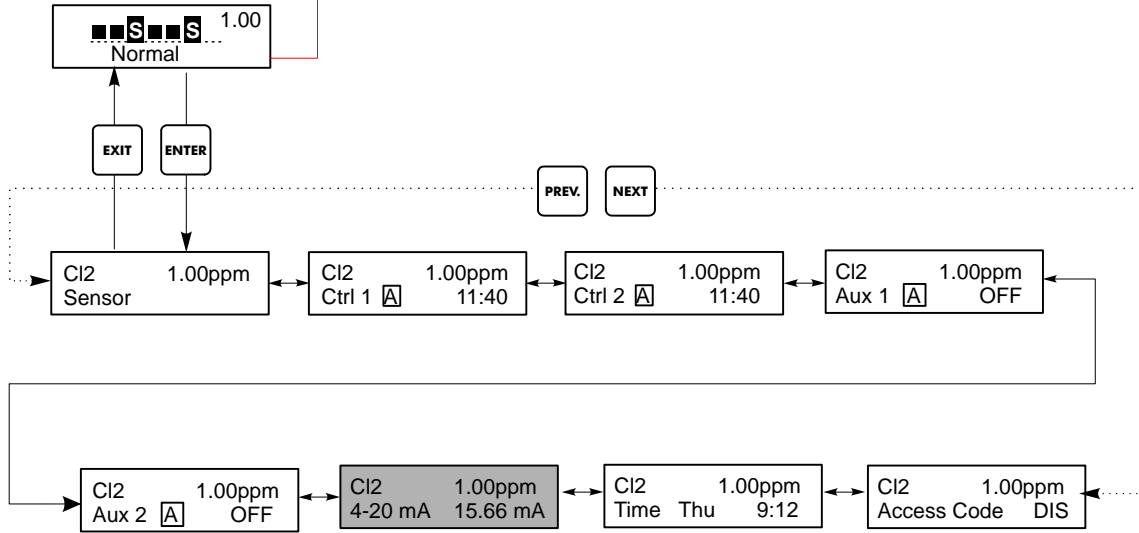

Legend

4-20mA menu is only present if 4-20mA option is installed.

Operation

Press Enter key to enter menu or submenu.
 Press Exit key to exit menu.
 After 10 minutes of inactivity the controller will automatically return to the summary screen.

Main Menu

5.2 Sensor Menu

The sensor menu provides the following settings: Calibration history (informational only), 1 point calibration, zero calibration, sensor type selection, and other sensor setup menus. Each is discussed in detail below. Refer to the Sensor Menu chart on the next page.

Note: If you are programming the unit for the first time you must set the Sensor Type first, selecting between Chlorine (CL2), Chlorine Dioxide (ClO2), Ozone, or Peracetic Acid. See below.

Cal'd

Displays the date of the last sensor calibration.

Calibration

Press **ENTER** to perform a 1 point process calibration of the sensor.

With the sensor installed in the flow cell, and a sample circulating at the normal flow rate, and the oxidizer concentration at the normal level, press **ENTER** at the Calibration screen. The display will show a ppm reading. If this does not match the known ppm as measured by a test kit or titration, use the arrow keys to change the displayed value and press **ENTER**.

Cal Successful/Cal Failed

If the sensor response is good, then the display will read "Cal Successful". If the controller cannot calculate an acceptable slope from that mV reading, it will read "Cal Failed". A failure usually means that the sensor needs to be cleaned or replaced.

Zero Calibration

This menu is used to calibrate the sensor to read precisely zero in pure water. It should be set at installation with the sensor in air or pure water. This zero procedure should be repeated if a new sensor is installed.

Press **ENTER** to start the zero adjust procedure. When asked "SnsrInPureWater?", remove the sensor from the flow cell and dry it off. Alternatively, supply the flow cell with a sample of water without any oxidizer in it. Use the arrow key to change the "N" to "Y" and press **ENTER**. You will be asked to press **ENTER** when the mV reading on the top line is stable. If the sensor offset was less than ± 100 mV, the display will flash "SensorCalSuccess" and return to the Zero Calibration display. You may now press **EXIT**.

If the message "BadZero: CalFail" appears, the offset was too large for the software to compensate. Check to see that the sensor is out of the bath and is dry and that all wiring connections are correct. If none of these corrects the problem, install a new sensor.

Days Btwn Cal

Use the arrow keys to set the number of days that you would like to go by before recalibrating the sensor. The controller will prompt you to recalibrate when that time has expired. Setting the number of days to zero will disable this feature.

Sensor Menu

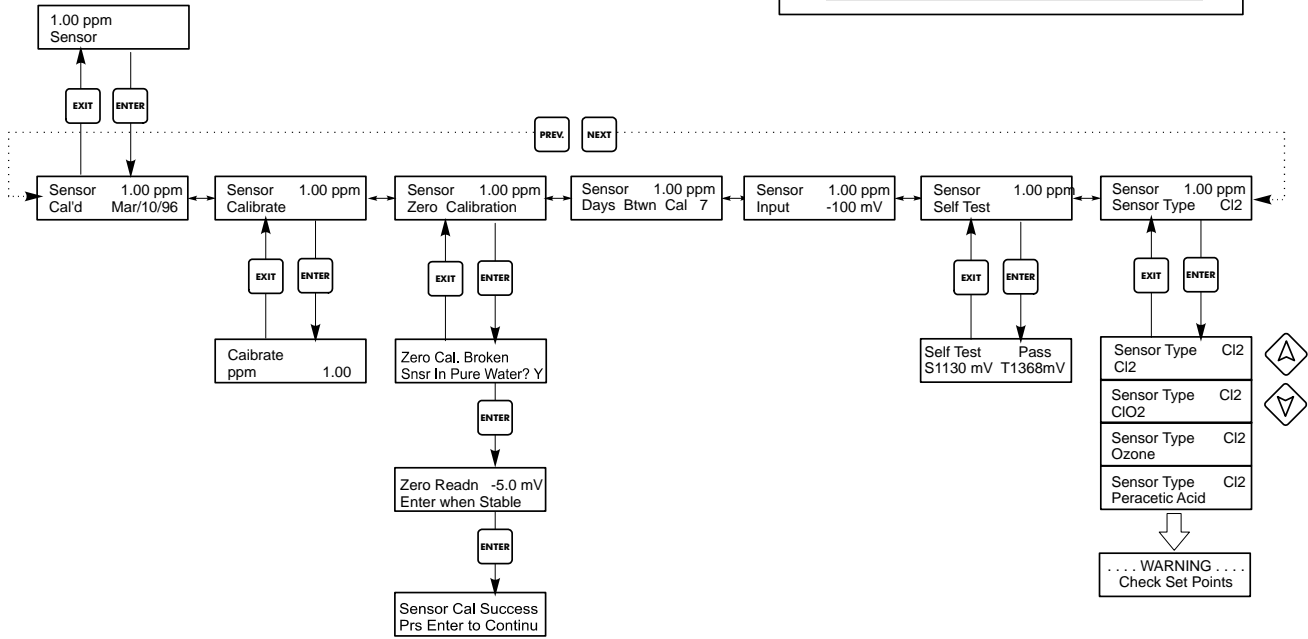

Legend

- Menu choices that appear when Buffer Recognition is selected.
- Menu choices that appear only when Auto Temperature Compensation is not recognized.

Operation

- Press Enter key to enter menu.
- Press Exit key to exit menu.
- Blinking fields may be edited with the adjust arrows.
- Press Enter when modification is complete to return to Main Menu Level.

Sensor Menu

Input

This menu displays the mV from the sensor. It is useful for troubleshooting. The sensor should be around 0 mV at 0 ppm and -100 mV per ppm (if chlorine, chlorine dioxide or ozone) or -10 mV per ppm (if Peracetic Acid).

Self Test

Press **ENTER** to perform a self-test. If it says "FAIL" in the upper right hand corner, try again with the sensor wires disconnected. If it still says "FAIL", this indicates a problem with the controller which should be returned for repair. If it passes, and you have a problem calibrating, it is sensor problem.

Sensor Type

Press **ENTER** to set up the controller to match the type of sensor to be used. Use the Up and Down arrows to toggle between Cl2 (chlorine), ClO2 (chlorine dioxide), Ozone and Peracetic Acid, then press **ENTER** to make your selection. The controller will warn you to check your set points because the acceptable range of set points may have changed.

Press any key to clear the warning message.

5.3 Control 1 and Control 2 Menus

The Control 1 and Control 2 menus are separate from each other but operate in exactly the same way. Each menu provides the following independent settings: Set Point, Dead Band, Time Limit, Interlock, Control Direction, HOA, Set Point, Dead Band, and Time Limit.

The top level menu status line may display the following messages: Off, Intrlck, Timeout, or a time. "Off" indicates that the output is off. "Intrlck" indicates that a signal from a flow switch or level switch is stopping control and has disabled the control outputs. "Timeout" indicates that the output has been on for longer than the maximum time programmed by the user. The time shows that the output is on, and has been for that amount of time. Refer to the Control 1 & 2 menus on the following pages.

Hi/Lo Set Point

Use the arrow keys to adjust the display to read the desired set point value. Press **ENTER** to accept the change. To feed an oxidizer, select Low Set Point. To feed a reducing agent, select High Set Point. This selection is made in the Control Direction menu described below.

Dead Band

Use the arrow keys to set the desired dead band, then press **ENTER**. If the low set point is 1.00 ppm, and the dead band is 0.05 ppm, then the relay will close at 1.00 ppm and open at 1.05 ppm.

Time Limit

Use the arrow keys to set the time limit in min:sec for the output to be active, then press **ENTER**. If it is set for "0:00", no limit will be imposed, and the output could stay on forever.

Interlock

Use the Up and Down arrows to toggle between Y(Yes) and N(No). Choosing Y means that the output will deactivate if the device attached to the controller is open. For example, if the sensor is installed in a recirculating pipe line, a flow switch that is closed if flow is sufficient and open if flow

is insufficient may be installed in the line, so that if flow past the sensor stops, the controller will not pump in chemicals based on a stagnant sample. Similarly, a level switch may be attached to prevent control of an empty batch tank.

Control Dir

Press **ENTER** to change the direction of control, then use the Up and Down arrows to toggle between High Set Point and Low Set Point, and press **ENTER** to make your choice. A low set point will turn on the relay when the process value goes below the set point value (to add an oxidizer, or as a low alarm). A high set point will turn on the relay when the process value goes over the set point value (to add a reducing agent, or as a high alarm).

HOA

Use the Left and Right arrows to move between Hand, Off and Auto. In Hand (Manual) mode, the output will be turned on immediately for a maximum of 10 minutes. In the Off mode, the output will be turned off indefinitely. In the Auto mode, the output turns on and off in response to changes in the process value relative to the set point. The letter inside the block on the status screen indicates which mode the output is in.

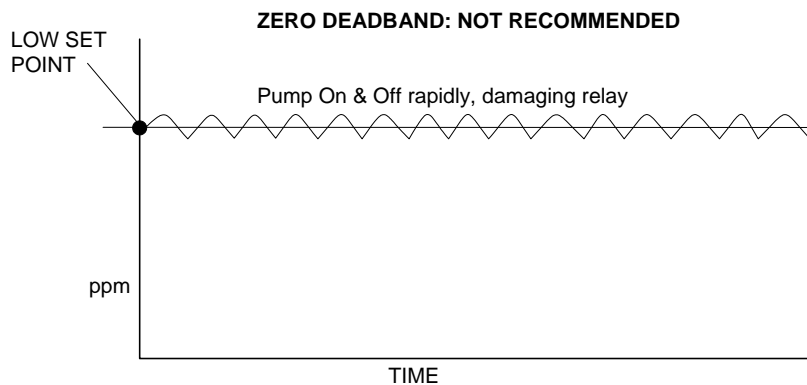
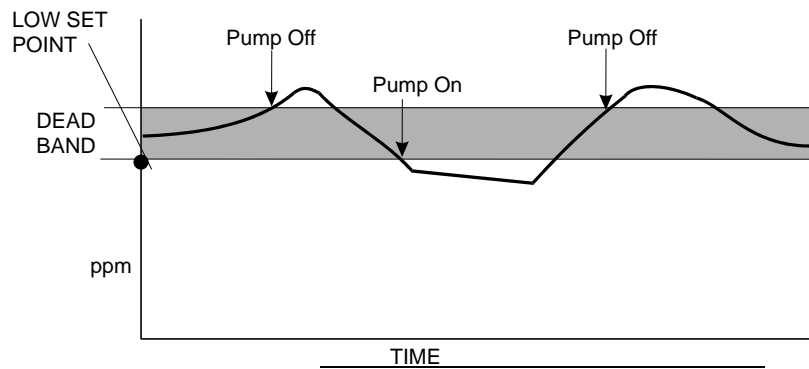

Ctrl 1 & 2 Menu

Possible status screens

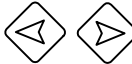
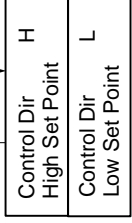
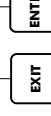
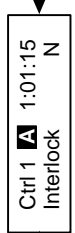
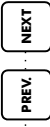
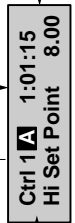
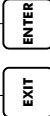

Legend

- Menu choice that appears when Control Direction High is selected.
- Menu choice that appears when Control Direction Low is selected.
- Only appears if time limit has expired.

Operation

Press Enter key to enter menu.
 Press Exit key to exit menu.
 Blinking fields may be edited with the adjust arrows.
 Press Enter when modification is complete to return to Main Menu Level.

5.4 Auxiliary 1 and 2 Menu

The Aux 1 and 2 relays may be configured to operate in a number of ways. They may be a low alarm, high alarm, an out-of-range alarm, an in-range output, or a probe wash.

The Aux 1 and 2 menus provides the following settings, which only appear if the appropriate output mode is selected: Low Alarm Pt, High Alarm Pt, Probe Wash Sched, Hold Time, Mode. Refer to the Auxiliary 1 and 2 Menu chart.

Note: When programming the controller for the first time, set the Output Control Mode first in order to display the correct menus for that mode. Press **ENTER** to get into the Aux 1 or Aux 2 submenus, then press **PREV** twice to get to the Mode menu.

Mode

Press **ENTER** then use the Up and Down arrows to toggle between the various choices:

Low Alarm

Press **ENTER** if you want the Aux relay to close if the process value goes below a certain value.

High Alarm

Press **ENTER** when this is displayed if you want the Aux relay to close if the process value goes above a certain value.

Out Range Alarm

Press **ENTER** if you want the Aux relay to close if the process value goes either above or below certain values.

In Range Output

Press **ENTER** if you want the Aux relay to close if the process value is between two values. This is useful to open a solenoid valve if the oxidizer concentration has been corrected and you want to empty a batch tank.

Probe Wash

Press **ENTER** if you want to use the Aux relay to interrupt control and activate a pump or valve to clean the sensor membrane.

Lo Alarm Pt

Only appears if either the low alarm, in range output, or out range alarm mode has been selected.

Use the arrow keys to adjust the process value below which the relay will close. (In the in-range mode, it is the process value ABOVE which the relay will close).

Hi Alarm Pt

Only appears if either the high alarm or in/out range mode has been selected.

Use the arrow keys to adjust the process value above which the relay will close. (In the in-range mode, it is the process value BELOW which the relay will close).

Dead Band

Use the arrow keys to set the desired dead band, then press **ENTER**.

Probe Wash Sched

Only appears if the probe wash mode has been selected.

Press **ENTER** to program the probe wash schedule. The display may read "Event A 12:00 20" which indicates that the probe wash will start at noon and the pump will run for 20 seconds. Use the arrow keys to change the time of day or the pump on-time. The maximum wash time is 99 seconds. If the sensor needs to be cleaned more than once a day, as many as nine additional events may be accessed by pressing **NEXT**. The time is Military time (1:00 PM = 13:00).

Press **EXIT** to go back to the Aux 1 menu level

Hold Time

Only appears if the probe wash mode has been selected.

Use the arrow keys to select the time delay in seconds between the probe wash ending and control beginning again. The hold time can be programmed for a maximum of 99 seconds.

HOA

Use the Left and Right arrows to move between Hand, Off and Auto. In Hand (Manual) mode, the output will be turned on immediately for a maximum of 10 minutes. In the Off mode, the output will be turned off indefinitely. In the Auto mode, the output turns on and off in response to changes in the process value relative to the set point. The letter inside the block on the status screen indicates which mode the output is in.

Possible Status Screens

- Aux 1 A 1:05
- Aux 1 A OFF
- Aux 1 A PW

Auxiliary 1 and 2 Menu

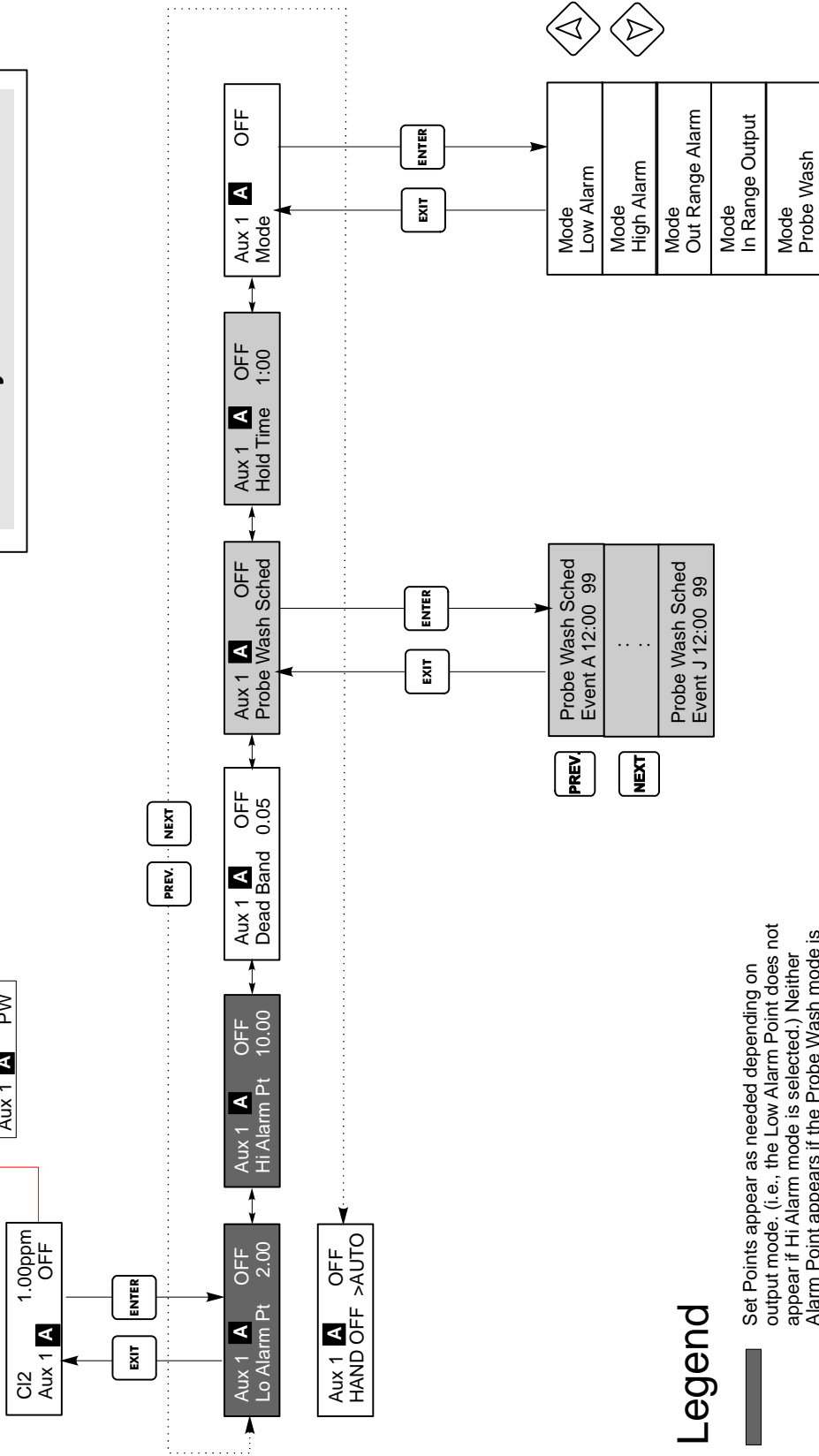

Legend

- Set Points appear as needed depending on output mode. (i.e., the Low Alarm Point does not appear if Hi Alarm mode is selected.) Neither Alarm Point appears if the Probe Wash mode is selected.
- Menu choices that appear when Probe Wash mode is selected.

Auxiliary 1 and 2 Menu

5.5 4-20 mA Menu (Optional)

This menu will only appear if the optional 4-20 mA output board is installed. It is used to set the scale of the 4-20 mA output. It contains the following menu selections: 4 mA Point, 20 mA Point, and Calibrate.

4 mA Pt

Use the arrow keys to enter the process value, in ppm, that you want to correspond to a 4 mA output from the controller.

20 mA Pt

Use the arrow keys to enter the process value, in ppm that you want to correspond to a 20 mA output from the controller.

Calibrate

This menu is used to calibrate instruments connected to the mA output. The 4-20 mA output is extremely accurate and stable and therefore will never need calibration. This feature allows other devices to be calibrated at the 4 and 20 mA points. Press **ENTER** to start the calibration.

Fixed 4 mA Out

The controller will output 4.00 mA. Adjust the chart recorder or data logger per its instruction so that the process value displayed is what is expected for a 4.00 mA input.

Fixed 20 mA Out

As above, except that the controller will output 20.00 mA.

The design of the 4-20 mA output is such that it should never need calibration. If the mA signal is not what it should be, call the factory for service.

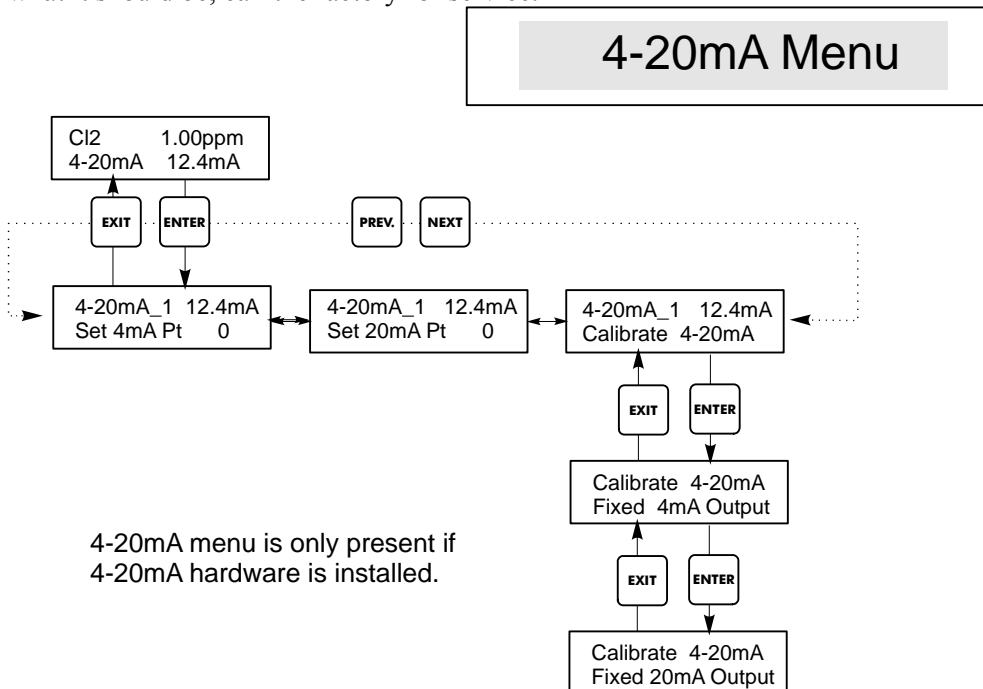

4-20 mA Menu

5.6 Clock Menu

The clock menu is used to set the date and time that the controller uses to schedule probe washing and calibration prompts. There is only one menu selection: Set Clock.

Set Clock

Press **ENTER** to set the clock. Use the arrow keys to change the year, date, and month, then press **ENTER**. Use the arrow keys again to set the day of the week and the time. Use military time (for example, 1:00 PM is 13:00). Press **ENTER** to return to the top level clock menu.

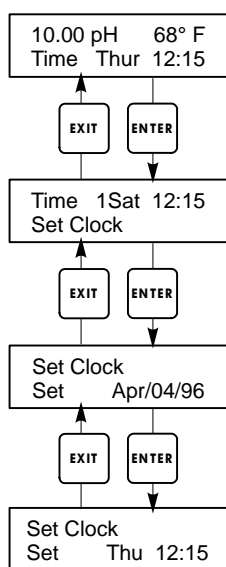

Set Clock Menu

5.7 Access Code Menu

This menu determines whether the access code feature of the controller is enabled or disabled and allows you to customize the access code to your own value. The access code controls whether or not you are allowed to change the parameters in the controller. With the access code disabled, any user may change any parameter. With the access code enabled, any user can view any parameter, but cannot change them.

Once an attempt is made to change a parameter, the display will prompt the user to enter the access code. If the correct code is entered, the parameter can be changed. (If the cursor is blinking, a change will be allowed; if the number or words are not blinking, they can't be changed). Once the correct access code has been entered, it will remain valid until there is a period of 10 minutes without a key being pressed.

Possible status screens are: Access Code REQ, Access Code OK, and Access Code DIS.

The first indicates that the access code is required to alter settings. The second indicates that the access code is required and has been entered correctly, and the last indicates that the access code has been disabled.

Enable Y/N

Use the arrow keys to select Y(Yes) or N(No) and press **ENTER** to enable or disable the access code. If the code was enabled, you must enter the access code in order to disable it.

New Access Code

Press **ENTER** to display the current access code value and use the arrow keys to change it to any value between 0 and 9999. If the access code has been enabled, you will be prompted to enter the current access code before being allowed to change it.

The factory default access code is 1995.

If you change the access code and can't remember it, follow this procedure:

1. Turn off the power to the controller.
2. Wait 10 seconds.
3. Press and hold the Up and Down arrow keys while turning on the power.
4. Read the access code on the display.
5. Release the arrow keys and the code will disappear.

Access Code Menu

Any Top Display
Access Code 0000

The Access Code prompt may appear at any screen in the entire menu structure if the current access code has not been entered by the user. Access code entries will be valid for 10 minutes from the most recent key press.

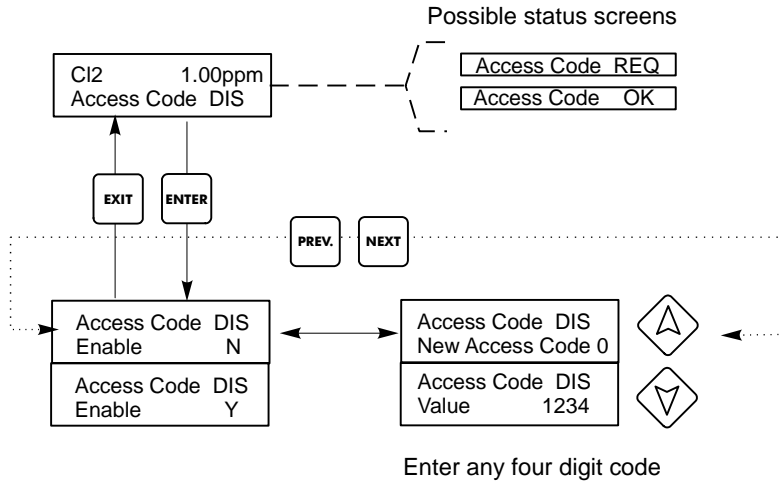

Access Code Menu

6.0 Maintenance ---

The WDIS control module itself needs very little maintenance. Clean the outside of the controller enclosure with a damp cloth. Do not spray down the controller unless the enclosure door is closed and latched. "Pigtails" should be protected from spray or wash-down. Check the cords and cables for damage.

6.1 Sensor Maintenance

Cleaning the Membrane

Instructions for cleaning the membrane vary depending upon the type of contamination. Follow the directions for replacing the membrane shown below, replacing step 3 with one of these cleaning methods:

For general deposits:
Rinse in clear cold water.

For calcium scale:
Soak in dilute (1% by volume) hydrochloric acid, then rinse in clear cold water.

For oils:
Rinse in isopropyl alcohol.
DO NOT use cleaners or detergents containing surfactants, as these will reduce the life of the membrane.

If the sensor still cannot be calibrated after cleaning, replace the membrane cap as described below.

Replacing the Membrane



CAUTION: Wear gloves and safety glasses during assembly of the sensor since the electrolyte is a **STRONG ACID**. It is recommended to perform this operation over a sink with running water available. After using, re-cap any remaining electrolyte until the next use.

1. Hold the sensor vertically with the membrane facing down and carefully unscrew the membrane cap. Always move the gray bands to uncover the vent hole before removing the cap!
2. Rinse the electrolyte fill solution off the cap and electrodes with cold water.
3. Discard the old membrane cap.
4. Unpack the new membrane cap, taking care not to touch the membrane or get it dirty.
5. Fill the membrane cap to the top with the electrolyte fill solution.
6. Hold the sensor body vertically with the tip pointing down and **SLOWLY** screw on the membrane cap until it is hand tight. **Be prepared for some electrolyte solution to squeeze out from the cap**
7. Rinse your hands, the sensor, and all surfaces contaminated with electrolyte solution with running water.
8. Check the sensor for leaks, especially at the membrane and the membrane cap threads. If any leaks are detected, tighten the membrane cap or replace it.

6.2 Replacing the Fuses

CAUTION: Disconnect power to the controller before opening front panel!

Locate the fuses on the circuit board at the back of the controller enclosure. (See figure 3.) Gently remove the old fuse from its retaining clip and discard. Press the new fuse into the clip, secure the front panel of the controller and return power to the unit.

Warning: Use of non-approved fuses can affect product safety approvals. Fuse ratings depend on controller power rating. Specifications are shown below. To insure product safety certifications are maintained, it is recommended that a Walchem fuse be used.

Controller Rating	F1	Walchem P/N	F2	Walchem P/N
120VAC	5x20mm,0.125A,250V	102369	5x20mm,10A,125V	102432
240VAC	5x20mm,0.063A,250V	103363	5x20mm,5A,250V	102370

7.0 Troubleshooting

CAUTION: Disconnect power to the controller before opening front panel!

Troubleshooting and repair of a malfunctioning controller should only be attempted by qualified personnel using caution to ensure safety and limit unnecessary further damage. Contact the factory.

7.1 Error Messages

Calibration Time

This message appears to prompt you to perform the routine maintenance of cleaning and calibrating the sensor. It does not appear based upon any analysis of the condition of the sensor. The frequency of calibration is set by the user in the "Days Between Cal" menu found in the "Sensor" menu. If you do not want to be prompted to perform a calibration, set this menu to "0".

Cal Failed

The expected response is -100 mV/ppm for Cl₂, ClO₂, and Ozone, or -10 mV/ppm for Peracetic Acid. The acceptable range is for -100 mV (or -10 mV for PAA) to equal 0.5 to 2.0 ppm. If the sensor response is outside the acceptable range, refer the sensor's instruction manual for troubleshooting.

Sens Low No Cal

The Calibrate menu will not allow a calibration if the concentration is too close to zero ppm. If the sensor input is above -5 mV (approximately 0.05 ppm), this message will appear. If the actual concentration is actually higher, refer to the sensor's instruction manual for troubleshooting.

Probe Error No Cal

The Calibration menus will reject the calibration if the sensor is in a Probe Error condition. Refer to the troubleshooting for Probe Error below.

Bad Zero Cal Fail

The Zero Calibration will fail if the mV reading from the sensor is outside of the range –100 to 100 mV. If the actual concentration is actually zero, refer to the sensor’s instruction manual for troubleshooting.

Output Timeout

This error message appears if one of the control outputs has been on longer than the maximum amount of time programmed in the "Time Limit" menu found in the "Control 1" or "Control 2" menus. It is reset by answering "Yes" to the "Reset Timer" prompt that will appear. There are a number of possible reasons that the output could go on for longer than normal:

Possible Causes	Corrective Action
1. The process went further out of control than normal.	Increase time limit or reset timer.
2. The chemical supply has run out.	Replenish the chemical supply.
3. The pump or valve or supply line is faulty.	Repair or replace the control device.
4. Wrong chemical is being controlled.	Replace with correct chemical.
5. The sensor is not responding to changes.	Repair or replace sensor or cable. Refer to sensor instructions. Evaluate mixing or recirculation.

High Alarm

This error message appears if the reading exceeds the set point for one of the AUX outputs that has been configured as a high alarm output. There are a number of possible causes for this condition:

Possible Causes	Corrective Action
1. The process went further out of control than normal.	May have to increase chemical flow rate.
2. The chemical supply has run out.	Replenish the chemical supply.
3. The pump or valve or supply line is faulty.	Repair or replace the control device.
4. Wrong chemical is being controlled.	Replace with correct chemical.
5. The electrode is not responding to changes.	Repair or replace sensor or cable. Refer to sensor instructions. Evaluate mixing or recirculation.
6. The pump is siphoning, valve leaking.	Repair or replace the control device or re-route tubing.
7. Control output has been left in "HAND" mode.	Switch back to "AUTO".
8. It may be a normal part of the process.	None required.

Low Alarm

As above for "High Alarm", except that the reading is below the set point of one of the AUX outputs that has been set up as a low alarm output. Refer to the possible causes and corrective actions listed above for the "High Alarm" error message.

Out Range Alarm

This error message appears if the reading is outside of the range selected for one of the AUX outputs that has been programmed as an "Out of Range Alarm". Refer to the possible causes and corrective actions listed above for the "High Alarm" error message.

In Range Output

This error message appears if the reading is inside of the range selected for one of the AUX outputs that has been programmed as an "In Range Alarm". Refer to the possible causes and corrective actions listed above for the "High Alarm" error message.

Probe Error

This error message appears if the sensor input signal is outside of the normal range. This usually indicates that the sensor has been disconnected or is faulty. It could appear under normal conditions if the Cl₂, ClO₂ or Ozone is outside of the operating range of 0 to 10 ppm, or if the Peracetic Acid is outside of the normal range of 0 to 100 ppm.

Possible Causes

1. Controller is faulty; fails self test
(see section 5.2)

2. Sensor has no power to it.

3. Sensor is faulty.

4. Sensor is faulty

Corrective Action

Re-check sensor self test with the sensor cable disconnected. If it still fails, send controller back for repair. If it passes, sensor is faulty.

Check +5V, -5V terminals vs COM terminal.
Should read +5VDC $\pm 5\%$ and -4.6 VDC $\pm 5\%$.

Indicated if ± 5 VDC power out of spec w/sensor attached, but in spec without sensor attached.
Repair or replace sensor.

Repair or replace sensor or cable.
Refer to sensor instructions.

Interlock

This error message indicates that control has been stopped because the dry contact signal from a flow switch or level switch is now open and one or more control outputs have been programmed to interlock.

Possible Causes

1. Flow has stopped, level too low.

2. Flow, level switch disconnected.

3. Flow, level switch faulty.

Corrective Action

May be a normal condition, otherwise restore flow or level.

Reconnect.

Verify that switch closes using an ohmmeter. If not, repair or replace.

4. Controller faulty.

Check the flow switch input by removing the switch wires and manually shorting the input using a short piece of wire. If the Interlock condition persists, repair the controller. If it goes away, problem is in the switch or cable.

Check Set Points

This is a normal display if you have changed the type of sensor from one type of sensor to another. The default set points for each choice is different, and will not match what you need for your application. Always select the sensor type before setting the control or auxiliary output set points.

8.0 Service Policy

The WDIS Series Disinfection Controller has a 2-year warranty on electronic components and a 1-year warranty on mechanical parts (keypad, terminal strip and relays).

We stock circuit boards for immediate exchange after we have isolated the cause of the problem.

Factory authorized repairs that are received by next-day-air will be repaired within 24 hours. Normal priority for returns is two weeks.

Out of warranty repairs or circuit board exchanges are done on a flat fee basis after the warranty is expired.