

OVERVIEW

Walchem's WDIS Series controller will reliably and economically control your water treatment disinfection process. There are no reagents, and the user may select from four sensor inputs: free chlorine, chlorine dioxide, ozone and peracetic acid.

The WDIS Series controller takes the guesswork out of your disinfection process. The chemical concentration is continuously monitored and controlled to the precise range required for proper system control and regulatory compliance.

Designed to be flexible and versatile, the WDIS Series controller is the ideal solution for disinfection applications in cooling towers, food & beverage, drinking water, wastewater and swimming pools.

Integrated datalogging is available to validate system performance. A USB memory stick is all that's needed to extract data and event logs that include disinfection sensor measurements and relay status. Download log files from the USB stick to a PC at your convenience. It couldn't be easier!



SUMMARY OF KEY BENEFITS



Versatility for a Broad Range of Applications

Choose from four industrial grade sensors in one controller - chlorine, chlorine dioxide, ozone, or peracetic acid. Relays can be configured for Hi Alarm, Low Alarm, Out-of-Range Alarm, In-Range Output or Probe Wash, providing unmatched flexibility.



Economical and Simple to Use

WDIS controllers are economically priced and do not require any costly reagents. The rugged NEMA 4X enclosure and panel mounted flow assembly has only two process connections for quick and easy installation.



Built-in Safety Features

Programmable output limit timers prevent run-away chemical addition. Digital Interlock Input may be used from a flow switch or level input to prevent chemical addition based on a stagnant sample, or control of an empty batch tank. The alarm relay notifies plant personnel of alarm conditions as soon as they occur.



Simple, Integrated Data Collection

Download stored data from the controller to a USB stick. Use the data to simply and easily validate system performance, document compliance and reduce liability. The data and event logs show disinfection levels, as well as accumulated chemical feed and relay activation times.



WDIS410 Series | Disinfection Controllers

» Versatile relay configuration

- Control outputs can be set as high or low set points via keypad. Auxiliary outputs can be set as:
 - High alarm
 - In-range output
 - Out of range alarm
 - Low alarm
 - Probe wash

» Probe wash feature

- For applications that require frequent electrode cleaning, automatic probe wash extends the time between maintenance interruptions

» Programmable access code

- Secures set point parameters and prevents unauthorized use. Program any four digit access number or disable the code requirement.

» Display status as a glance

- Look any set point without interrupting control or needing access code. Top level view:
 - Analog graph relative to set point
 - Free chlorine, chlorine dioxide, peracetic acid or ozone values
 - Status of alarms, outputs

» Self diagnostics

- Software and electronics are constantly monitored without having to take the controller off-line. Any error messages are clearly displayed. A fifth relay is activated by any diagnostics failures.

» USB Flashstick Support

- Optional for data logs, event/relay and reset logs, and user configuration file import/export

Disinfection Sensors | Free Chlorine • Chlorine Dioxide • Peracetic Acid • Ozone

» Long-lasting amperometric electrode with rugged membrane

» Integrated temperature compensation

» Relatively insensitive to changes in sample flow rate

» Large openings in flow cell prevent clogging

» Excellent long-term stability

Free Chlorine

Chlorine is the most common disinfectant used in water treatment. It's readily available, inexpensive, and typically used in drinking water, swimming pools, cooling towers and process water applications.

Chlorine Dioxide

Chlorine dioxide is a very strong oxidant that is often used for disinfection in drinking water, food & beverage, and cooling tower applications. It's preferred for some uses since it doesn't affect the taste and odor of the water being treated.

Peracetic Acid

Peracetic acid has been used for decades as a disinfectant in the food & beverage industry. Its use has grown to many other applications including bottling, CIP (Clean In place), laundry, pulp & paper, and agriculture.

Ozone

Ozone is the strongest oxidant used in water treatment. It is commonly used in drinking water (disinfection, oxidation, taste and odor control), food & beverage, swimming pools (therapy pools), zoos and aquariums.

Optional USB Features

- » Integrated datalogging collects analytical measurements at 10 minute intervals and captures all relay activations.

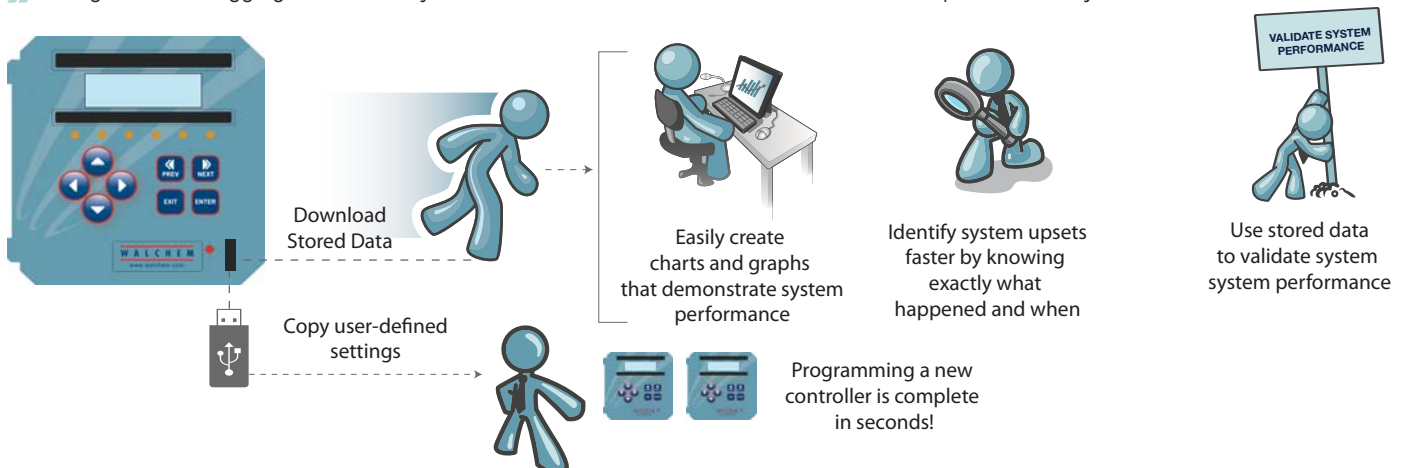

Dimensions

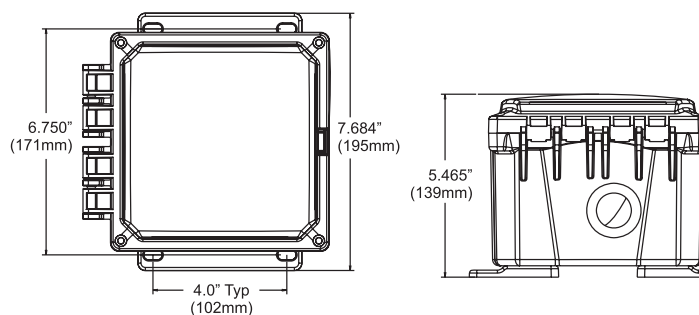

Inputs

Input Power 100-240 VAC, 50/60 Hz, 8A
Fuse: 1.0 ampere, 5 x 20 mm

Input Signals

Sensor ±2000 mV
Interlock (Optional) Isolated, dry contact closure required (i.e. flow, level)

Mechanical (controller)

Enclosure Polycarbonate
NEMA Rating NEMA 4X (IP65)
Display 2 x 16 character backlit liquid crystal
Ambient Temperature 32 to 122°F (0 to 50°C)
Shipping weight 7 lbs (3 kg) (approximately)

Sensor Specifications

Mechanical

Operating Temperature Chlorine Dioxide, Peracetic Acid, Ozone: 0 to 50°C (41 to 122°F)
Chlorine: 0 to 45°C (32 to 113°F)
Operating pressure 0 to 1 atm (0 to 14.7 psi)
Storage temperature 0 to 50°C (32 to 122°F)
Shelf life 1 year
Flow cell inlet 1/4" NPTF
Flow cell outlet 1/4" NPTF

Electrical

Power requirements ±5 VDC, 5 mA maximum
Signal 0 to -1000 mVDC
Max cable length 305 m (1000 ft)
Cable required 2 twisted pair, 24 AWG shielded,

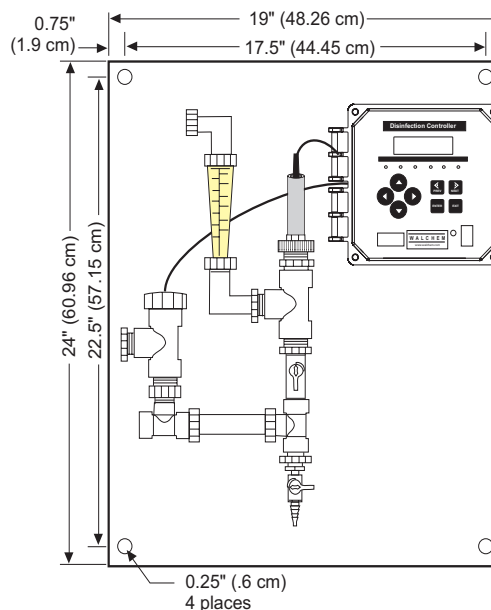

Outputs

Control 1, Control 2 (On/Off)

Two internally powered relays
6A (resistive), 1/8 HP
All relays are fused together as one group, total current for this group must not exceed 6A

Control 3, Control 4, Alarm

Dry contact relays
6A (resistive), 1/8 HP

4-20 mA 1 or 2 (optional)

Internally powered, Fully isolated
600 Ohm max resistive load
Resolution .001% of span
Accuracy ± 1% of reading

Sensor Power ±5VDC, 5 mA

Materials of Construction (Sensor)

Sensor Body PVC, Polycarbonate
Membrane Chlorine Dioxide, Peracetic Acid, Ozone: Silicone
Chlorine: PTFE
Flow cell body Isoplast
O-ring FKM

| | Chlorine Dioxide | Peracetic Acid | Ozone | Chlorine |
|------------------------------|--|----------------|--------------------|---|
| Range | 0-20 mg/l | 0-2000 mg/l | 0-20 mg/l | 0-20 mg/l |
| Resolution | 0.01 mg/l | 1 mg/l | 0.01 mg/l | 0.01 mg/l |
| Cross sensitivity | Free chlorine (5%), Ozone | | Free chlorine (5%) | Bromine, Ozone, Iodine, ClO ₂ , Di-/Tri-chloramine, or Bromamine |
| Flow rate of sample | 30 to 100 liters/hr (7.9 to 26.4 gallons/hr) | | | |
| pH range of sample | 1.0 to 14.0 | | | 6.8 to 8.0 |
| Conductivity range of sample | 50 to 10,000 μS/cm | | | |
| Response time | 30 seconds | 3 minutes | 30 seconds | 30 seconds |

ORDER INFORMATION

WDIS410 — voltage output sensor USB

VOLTAGE

1 = 120 VAC, prewired w/ USA power cord & 6" pigtails
5 = Hardwired, cable glands

OUTPUT

N = No data output
4 = One (1) Isolated 4-20 mA output
2 = Two (2) Isolated 4-20 mA outputs

SENSOR

N = No sensor
1 = Free chlorine sensor with flow cell & 20 ft. cable
2 = Chlorine dioxide sensor with flow cell & 20 ft. cable
3 = Ozone sensor with flow cell & 20 ft. cable
4 = Peracetic acid sensor with flow cell & 20 ft. cable
5 = Free chlorine sensor with flow manifold & 5 ft. cable on panel
6 = Chlorine dioxide sensor with flow manifold & 5 ft. cable on panel
7 = Ozone sensor with flow manifold & 5 ft. cable on panel
8 = Peracetic acid sensor with flow manifold & 5 ft. cable on panel

USB FEATURES

N = Software upgrade capability only
U = Integrated datalogging, event/reset logging, and configuration file import/export

AGENCY CERTIFICATIONS

| | |
|-----------|------------------------------------|
| UL | ANSI/UL 61010-1:2004, 2nd Edition* |
| CAN/CSA | C22,2 No.61010-1:2004 2nd Edition* |
| CE Safety | EN 61010-1 2nd Edition (2001)* |
| CE EMC | EN 61326 :1998 Annex A* |

Note: For EN61000-4-6,-3 the controller met performance criteria B.

*Class A equipment: Equipment suitable for use in establishments other than domestic, and those directly connected to a low voltage (100-240 VAC) power supply network which supplies buildings used for domestic purposes.



WebmasterONE®

WebMasterONE is the most powerful online cooling tower/boiler controllers in the water treatment industry. WebMasterONE couples a multi-I/O platform with Walchem's analytical sensors and extensive communications technologies. The result is the ability to remotely monitor and control your process from any computer, anywhere in the world, with just a standard web browser.



Metering Pumps

Walchem and Iwaki combined their talents to design the most innovative and comprehensive metering pump product line in the world. With over 50 years of combined pump experience, in an array of different markets, the Iwaki-Walchem partnership leverages our strengths to exceed even our toughest customer expectations. Committed to new product development, our pumps are innovative and revolutionary.



WIND WebMaster Industrial Water Controllers

Walchem's WebMaster® Industrial (WIND) Controller sets a new standard for Industrial Water Treatment Controllers. WIND has a flexible multi-I/O platform, a wide range of analytical sensor measurement capabilities, and an extensive assortment of integrated communications and data handling features.



WebAlert Remote Monitor

Walchem's WebAlert is the first stand alone remote monitoring device that can web enable your installed equipment without having to replace or upgrade it.

ABOUT US

Walchem integrates its advanced sensing, instrumentation, fluid pumping and communications technologies to deliver reliable and innovative solutions to the global water treatment market

Our in-house engineering is driven by quality, technology and innovation. For more information on the entire Walchem product line, visit: www.walchem.com

WALCHEM
An Iwaki America Company

Walchem, An Iwaki America Incorporated Company
Five Boynton Road Hopping Brook Park
Holliston, MA 01746 USA
Phone: 508-429-1110
Fax: 508-429-7433
www.walchem.com