

OVERVIEW

Walchem's WCU410 Copper Controller and WNI Nickel Controller are opto-electronic on-line analyzers that measure the actual concentration of copper or nickel in solution. They are used in a variety of applications including electroless plating baths and microetch baths (including oxide-replacement types).

The WCU410 may be switched from electroless copper to microetch via the menu, eliminating the need for a second controller. It reduces the need for manual titration, improves yield, and in microetch applications improves productivity by reducing the frequency of bath change-outs.

The WNI410 is available as nickel-only, or with a pH control option which may be added in the field. Two separate pump outputs for nickel and reducer and another for pH are used, each of which is capable of totalizing either pump on-time, volume pumped, or metal turnovers.

Integrated datalogging is available to validate system performance. A USB memory stick is all that's needed to extract data and event logs that include copper or nickel measurements, and relay status. Download logs from the USB stick to a PC at your convenience. It couldn't be easier!



SUMMARY OF KEY BENEFITS



Concentration Read in Units

Selectable between grams per liter (g/L) or ounces per gallon (oz/gal). Backlit digital display also acts as a bar graph for a continuous "visual summary" of measurement versus set point.



Operator Adjustable

Concentration set point, alarm set points (high and low), dead band and pump on time are all easily adjustable. An interlock feature allows external devices (such as a flow switch) to interlock control relays.



Simple, Integrated Data Collection

Download stored data from the controller to a USB stick. Use the data to simply and easily validate system performance. The data and event logs show copper or nickel values, as well as accumulated chemical feed and relay activation times.



Four Separate Control Relays & Outputs (WCU)

May be used to add copper, caustic, formaldehyde or chelator/stabilizer chemistries. Each output has a replenishment totalizer which may be set in units of time or volume.



Optional pH Input Board (WNI)

May be used to add pH adjustment chemistry. Output has a replenishment totalizer which may be set in units of time or volume.

WCU/WNI410 Series | Electroless Copper & Nickel Controllers

Typical Electroless Copper Application

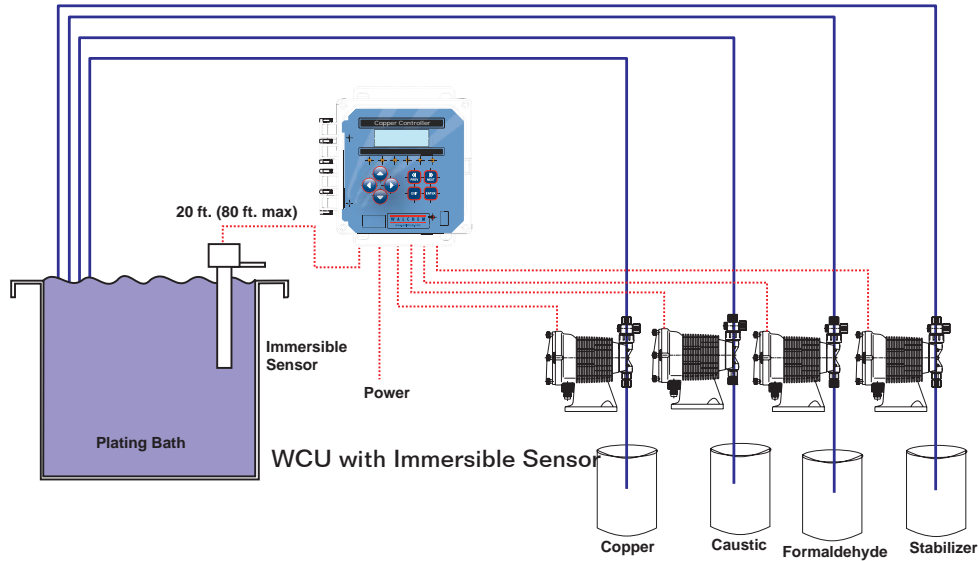

Typical Electroless Nickel Application without Degasser

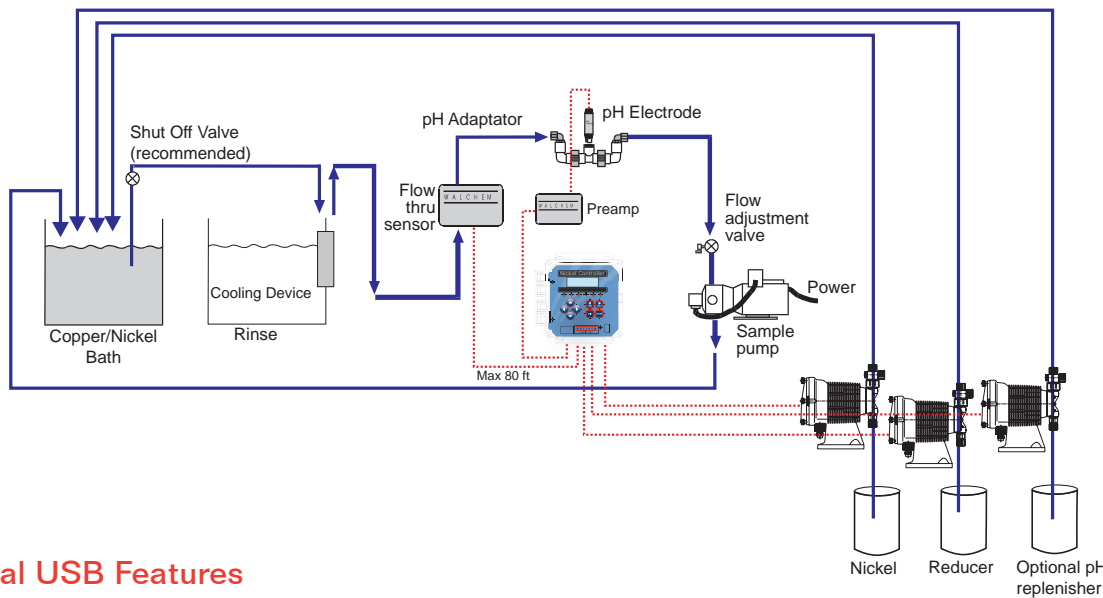

Optional USB Features

» Integrated datalogging collects analytical measurements at 10 minute intervals and captures all relay activations.

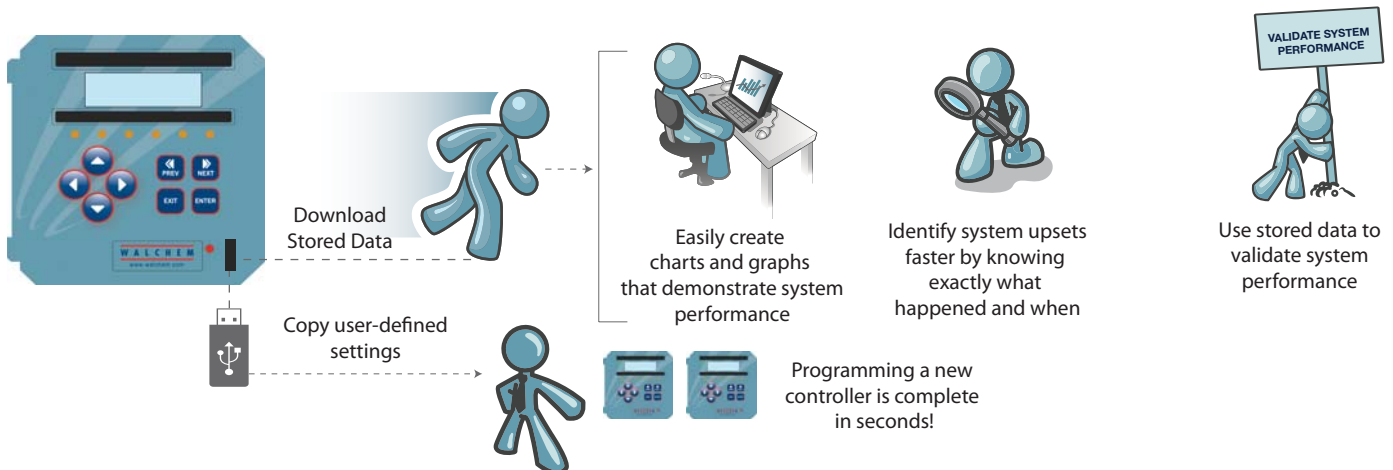

DIMENSIONS

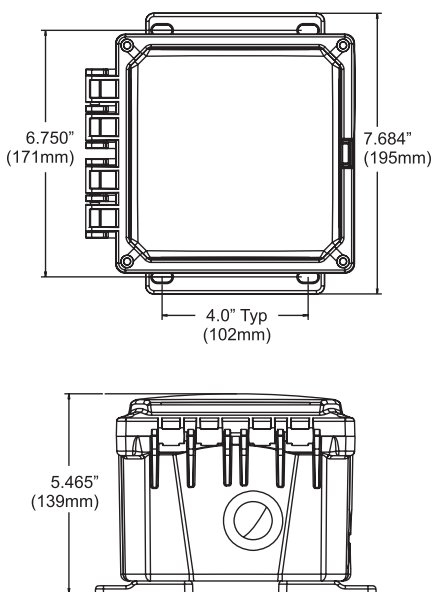

Flow through sensor

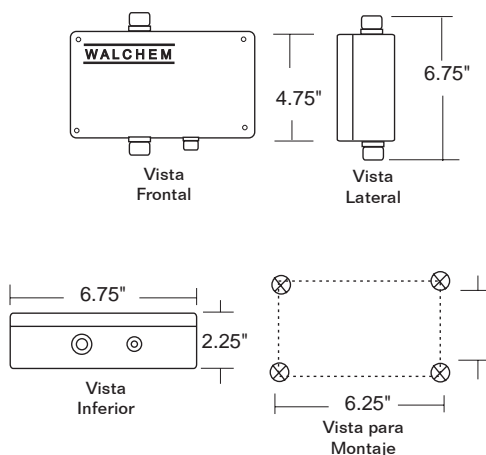

Immersible sensor

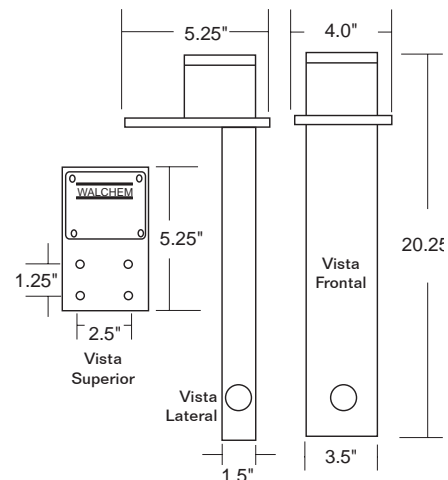

Inputs

Power

100-240 VAC, 50/60 Hz, 8A
Fuse: 1.0 ampere, 5 x 20 mm

Signals (optional)

WCU: Isolated, dry contact closure required (i.e. flow, level)
WNI: pH - accepts preamplified pH signal and a Pt100 or Pt1000 RTD for temperature compensation

Measurement Performance

WCU

Concentration Range	0.01 to 5.5 g/L (0.001 to 0.73 oz/gal) (Electroless copper)
Range	0.01 to 99 g/L (0.001 to 13.2 oz/gal) (Microetch copper)
Resolution	0.001 g/L (0.0001 oz/gal)
Accuracy	0.01 g/L (0.001 oz/gal)

WNI

Nickel Concentration Range	0.01 to 10 g/L (0.001 to 1.33 oz/gal)
Accuracy	0.01 g/L (0.001 oz/gal)

pH Range	0 to 14 pH
pH Resolution	0.001 pH
pH Accuracy	±0.01 pH

Temperature Range	0 to 100°C (32 to 212°F)
Temperature Resolution	0.05°
Temperature Accuracy	±0.1°

Outputs

Mechanical Relays (5)

Internally powered relays switching line voltage
6 A (resistive), 1/8 HP
All relays are fused together in one group, total current for this group must not exceed 6A

4 - 20 mA 1 or 2 (optional)

Internally powered
Fully isolated
600 Ohm max resistive load
Resolution .001% of span
Accuracy ± 1% of reading

Mechanical

Enclosure	Polycarbonate
NEMA Rating	NEMA 4X (IP65)
Display	2 x 16 character backlit liquid crystal
Ambient Temperature	32 to 122°F (0 to 50°C)
Storage Temperature	-20 to 180°F (-29 to 80°C)
Solution Temperature	WCU: 200°F (93°C) maximum WNI: 212°F (100°C) maximum
Sensor cable	80 ft. maximum, 20 ft. standard
Shipping weight	7 lbs (3 kg) (approximately)

AGENCY CERTIFICATIONS

UL	ANSI/UL 61010-1:2004, 2nd Edition*
CAN/CSA	C22,2 No.61010-1:2004 2nd Edition*
CE Safety	EN 61010-1 2nd Edition (2001)*
CE EMC	EN 61326 :1998 Annex A*

Note: For EN61000-4-6,-3 the controller met performance criteria B.

*Class A equipment: Equipment suitable for use in establishments other than domestic, and those directly connected to a low voltage (100-240 VAC) power supply network which supplies buildings used for domestic purposes.

ORDER INFORMATION

WCU410 — voltage output sensor USB

WNI41 — Dual Input voltage output sensor USB

DUAL INPUT

0 = None

1 = pH input*

VOLTAGE

1 = 120 VAC, prewired

5 = Hardwired, cable glands

OUTPUT

N = No 4-20 mA data output

4 = Single Isolated 4-20 mA output

SENSOR

N = No sensor

1 = Flow through sensor

2 = Immersible sensor (WCU only)

USB FEATURES

N = Software upgrade capability only

U = Integrated datalogging, event/reset logging, and configuration file import/export

*WNI: For easy installation, order sensor option "N" plus a 190921 (120VAC) or 190922 (240VAC) sample system when ordering the pH option.



Webmaster® ONE

WebMasterONE is the most advanced online cooling tower and boiler controller in the water treatment industry. The flexible multi-I/O platform allows you to control multiple cooling towers, boilers, closed loops, and condensate lines with just one controller. An extensive assortment of integrated communications and data handling features are included that enable water treatment professional to provide more effective water management services to their customers.



Metering Pumps

The E-Class is the most innovative and comprehensive metering pump product line in the world. Over 50 years of pump experience and a commitment to superior mechanical design has led to development of many industry firsts, including 360 stroke-per-minute technology, IP67 waterproof construction, and the world's highest capacity solenoid metering pumps.



WIND WebMaster® Industrial Water Controllers

Walchem's WebMaster Industrial (WIND) Controller sets a new standard for Industrial Water Treatment Controllers. WIND has a flexible multi-I/O platform, a wide range of analytical sensor measurement capabilities, and an extensive assortment of integrated communications and data handling features.



WebAlert® Remote Monitor

Walchem's WebAlert is the first stand alone remote monitoring device that can web enable your installed equipment without having to replace or upgrade it.

ABOUT US

Walchem integrates its advanced sensing, instrumentation, fluid pumping and communications technologies to deliver reliable and innovative solutions to the global water treatment market

Our in-house engineering is driven by quality, technology and innovation. For more information on the entire Walchem product line, visit: www.walchem.com



Walchem, An Iwaki America Incorporated Company
Five Boynton Road Hopping Brook Park
Holliston, MA 01746 USA
Phone: 508-429-1110
Fax: 508-429-7433
www.walchem.com