

OVERVIEW

WebAlert was developed to meet the increasing demands for improved operational efficiencies and enhancements to service programs that can be gained by continuous monitoring of remote equipment and systems.

WebAlert seamlessly web-enables your installed equipment, providing local and remote access to vital system information, without the need to physically visit remote sites. WebAlert monitors and datalogs analog and digital inputs from virtually any installed device, and notifies on-site and remote personnel of any system abnormalities.

The data handling and communications options in WebAlert are truly innovative. Ethernet and USB are standard features, therefore local or plant networked PC's can be connected and communicating with WebAlert in true Plug & Play fashion. Authorized operators and quality control personnel can view LIVE system parameters and historical graphs, as well as receive emailed alarms, reports or datalog files.



SUMMARY OF KEY BENEFITS



WebAlert integrates the functions of a monitor, data logger and auto-dialer in one low cost package. It is easily customized to your application without the need for a programmer.



No subscription service, monthly fees, or proprietary software is required. View data and program settings with just a standard web browser.



Monitor up to six (6) 4-20mA signals and six (6) discrete inputs.



Access live or stored data remotely within the facility (LAN) or from anywhere in the world.



System status reports and datalog files can be emailed automatically on a regular basis. Instant alarm notification via cell phone text message, email, or local alarm relay.

WebAlert® Series | Web-Based Remote Monitoring and Datalogging

» Convenience

- WebAlert has been designed with convenience and ease-of use in mind. It has extensive built-in datalogging capability so there's no need for a separate datalogging device. The data can be retrieved automatically (email Excel file attachment) or manually, through the convenience of a standard USB flash disk.



Simple data extraction to USB stick

» Simplicity

- Unlike PLC's or similar devices, WebAlert does not require a software programmer for customization to your application. This reduces upfront costs and eliminates recurring expenses for software maintenance. Commissioning is as simple as connecting with a laptop and following the intuitive menus to configure the WebAlert to meet your needs.



Receive spreadsheet datalogs as an attachment to an email at user-defined time periods.



Receive alarms via cell phone text messaging.

- A variety of reporting options can be utilized to meet your needs. A system summary report provides a snapshot of current conditions and alarms. A datalog report can be sent on a regular basis for historical trending. In addition, email and cell phone text alarm messages can be sent.

» Remote System Monitoring

- WebAlert will monitor up to six (6) 4-20mA signals and six (6) discrete inputs, giving you instant access (from anywhere in the world) to vital system parameters, including level, flow, pressure, temperature, or any other device with a standard 4-20mA or discrete output.

WebAlert Alarm Status: 1) ORP(AI_2) Low Alarm Controller Restart
Thu May 24 08:19:27 2007

4-20mA Inputs	Measure	Last 24 Hrs			Status	Total
		AVG	MIN	MAX		
pH(AI_1)	pH	7.65	7.65	7.65	Normal	N/A
ORP(AI_2)	ORP	-43.37	-43.35	-43.37	Low Alarm	N/A
FlowMeter2(AI_4)	Gal/min.	84.79	84.72	84.65	Normal	1323313.00 Gal
Bleach Tank(AI_5)	gal.	434.95	434.63	433.54	High Alarm	N/A
Acid Tank(AI_6)	gal.	40.55	40.55	40.55	Normal	N/A

Digital Inputs	Input Type	Status	Total	Rate
Flowmeter2(DI_1)	Contact Flow Meter	Normal	2251.29 gal	N/A
Flow_Switch(DI_2)	Generic Input	Flow 1 days,15:40:00	N/A	N/A
Switch1(DI_3)	Generic Input	Open1 1 days,15:40:00	N/A	N/A
FlowMeter1(DI_4)	Paddlewheel Flow Meter	Low Alarm	93903.92 gal	0.00 GPM
Switch2(DI_5)	Generic Input	Open2 1 days,15:40:00	N/A	N/A
Switch3(DI_6)	Generic Input	Open4 00:15:23	N/A	N/A

Output Status
Alarm Off

Online Device Management Service

- Critical Process Values
- Summary View of Devices
- One Click Live Connect
- Alarm Status
- Monthly Reports

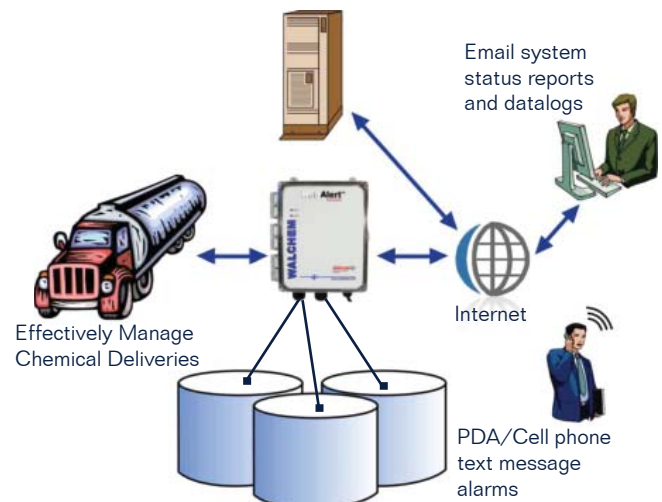

» Remote Chemical Inventory Management

- WebAlert is perfect for remote chemical inventory management. Level sensors and switches from a variety of sensing devices may be connected directly to the WebAlert, providing live information about chemical inventories, which makes management of chemical deliveries efficient, prevents down-time in critical processes, and provides immediate notification of alarm conditions. An online device management service from Walchem will be available to enable the user to view all of their locations on a single web page.

WebAlert's embedded web-server and TCP/IP Internet communications make it possible to establish local or remote communications with a standard web browser from a laptop or PC. USB and Ethernet are standard features, allowing easy on-site access for plant personnel and system operators. Remote communications can be accomplished via the Internet or over a phone line with the PSTN (landline) or Cellular modem option. WebAlert supports simultaneous multi-user access, which makes it possible for personnel from local and remote locations to view live data, troubleshoot, and configure the system more efficiently than ever before. A graduated password protection system allows users varied degrees of access from "view only" to "full configuration".

» **USB Plug and Play**

For local monitoring and reconfiguration of your WebAlert via Laptop or dedicated on-site PC.

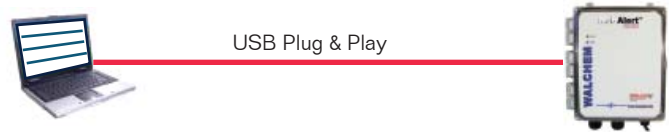

» **ShoulderTap® Internet Communications**

For monitoring and reconfiguration of your WebAlert remotely via the Internet (requires landline or cellular modem card option).

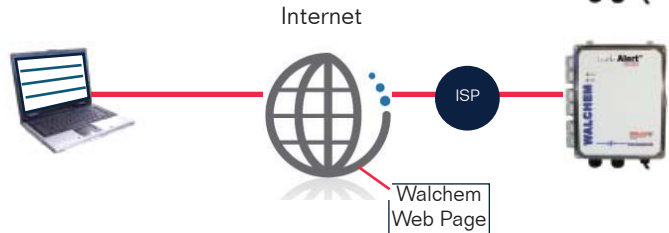

» **DirectTap Modem-to-Modem**

For remote monitoring and reconfiguration of your WebAlert using traditional modem-to-modem communications (requires landline modem card option).

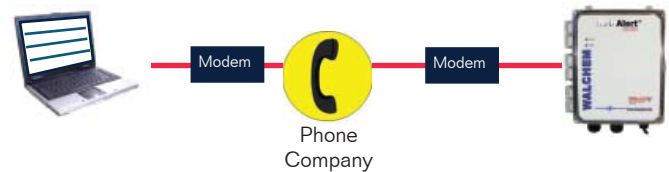

» **Ethernet**

For monitoring and reconfiguration of your WebAlert via Local Area Network or remotely via the Internet.

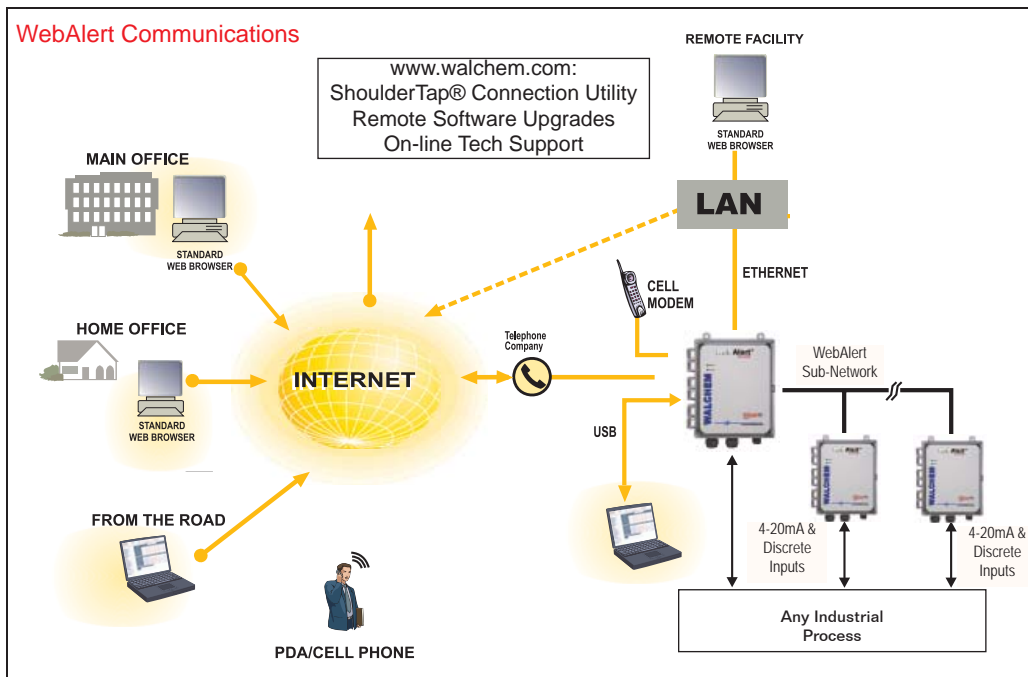
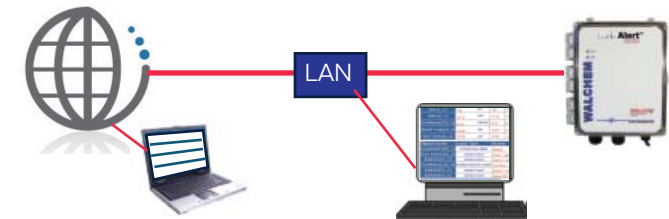

Ethernet Networking Option

By using the on-site Local Area Network (LAN) or by connecting the WebAlerts™ together via Ethernet, you can access all of the WebAlerts™ on a network from a single phone line or IP address. The "Master" WebAlert automatically detects the other WebAlerts™ and serves as a window to the "slaves" on the network, greatly reducing the cost and time associated with device configuration and running phone lines to each device. DHCP is supported to enable WebAlert to automatically obtain an IP address from the LAN.

ORDER INFORMATION

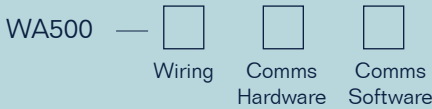

WIRING

H = Hardwired, cable glands
P = USA power cord w/cable glands

COMMUNICATIONS (USB & ETHERNET STANDARD)

N = No additional communications
M = Modem card
G* = Cellular modem card (GPRS North America)
F* = Cellular modem card (GPRS rest of world)
* Pending

COMMUNICATIONS SOFTWARE

N = None
1 = Ethernet Networking Master Capability

MECHANICAL SPECIFICATIONS

Enclosure Polycarbonate
NEMA Rating NEMA 4X (IP65)
Ambient Temperature 32 to 140°F (0 to 60°C)
Storage Temperature -20 to 176°F (-29 to 80°C)
Shipping weight 4.5 lbs (2 kg) (approximately)

DIMENSIONS

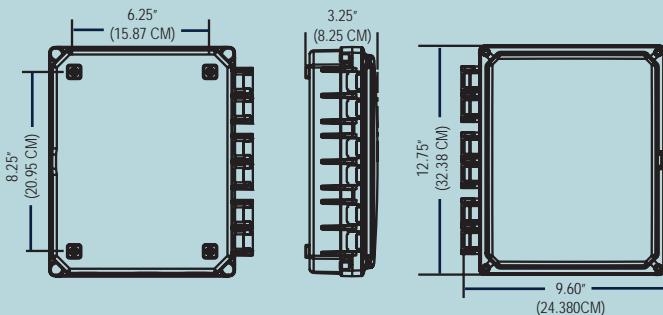

AGENCY CERTIFICATIONS

UL ANSI/UL 61010-1:2004, 2nd Edition*
CAN/CSA C22,2 No.61010-1:2004 2nd Edition*
CE Safety EN 61010-1 2nd Edition (2001)*
CE EMC EN 61326 :1998 Annex A*

Note: For EN61000-4-6,-3 the controller met performance criteria B.

*Class A equipment: Equipment suitable for use in establishments other than domestic, and those directly connected to a low voltage (100-240 VAC) power supply network which supplies buildings used for domestic purposes.



Measurement Performance (4-20mA Inputs)

Range: 3.75-20.25 mA
Resolution: 0.03 mA
Calibration: ±1 mA

Electrical

Input Power: 100-240VAC ±10%
1.0A, 50/60 Hz
Fuse 1.0A 5 x 20mm
Analog Input Signals (6): 4-20mA, 2 or 3 wire
Internally powered by 24 VDC
110 ohm input resistance
1000 ohm maximum load

Digital Input Signals (6)
Flow meter (D1-4 only): Isolated dry contact, 0-400 Hz (relay, reed switch, Hall effect)
1.5 msec minimum width

Switch (D1-6): Isolated dry contact, 0-400 Hz (relay, reed switch, Hall effect)
50 msec minimum width

Outputs
Solid State Relay: Dry contact 0-40 VDC
No AC voltage, 150 mA max load
USB, Ethernet, 10 Base T

Digital:



Webmaster®ONE

WebMasterONE is the most advanced online cooling tower and boiler controller in the water treatment industry. The flexible multi-I/O platform allows you to control multiple cooling towers, boilers, closed loops, and condensate lines with just one controller. An extensive assortment of integrated communications and data handling features are included that enable water treatment professionals to provide more effective water management services to their customers.



Metering Pumps

The E-Class is the most innovative and comprehensive metering pump product line in the world. Over 50 years of pump experience and a commitment to superior mechanical design has led to the development of many industry firsts, including 360 stroke-per-minute technology, IP67 waterproof construction, and the world's highest capacity solenoid metering pumps.

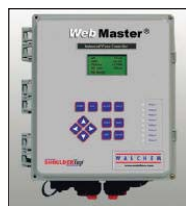

WIND WebMaster Industrial Water Controllers

Walchem's WebMaster® Industrial (WIND) Controller sets a new standard for Industrial Water Treatment Controllers. WIND has a flexible multi-I/O platform, a wide range of analytical sensor measurement capabilities, and an extensive assortment of integrated communications and data handling features.

ABOUT US

Walchem integrates its advanced sensing, instrumentation, fluid pumping and communications technologies to deliver reliable and innovative solutions to the global water treatment market

Our in-house engineering is driven by quality, technology and innovation. For more information on the entire Walchem product line, visit: www.walchem.com



Walchem, An Iwaki America Incorporated Company
Five Boynton Road Hopping Brook Park
Holliston, MA 01746 USA
Phone: 508-429-1110
Fax: 508-429-7433
www.walchem.com