

WebMaster® *ONE*
Water Treatment Controller
Instruction Manual

Notice

© 2008 WALCHEM Corporation
Five Boynton Road, Holliston, MA 01746 USA
(508) 429-1110
All Rights Reserved
Printed in USA

Proprietary Material

The information and descriptions contained herein are the property of WALCHEM Corporation. Such information and descriptions may not be copied or reproduced by any means, or disseminated or distributed without the express prior written permission of WALCHEM Corporation, Five Boynton Road, Holliston, MA 01746.

Statement of Limited Warranty

WALCHEM Corporation warrants equipment of its manufacture, and bearing its identification to be free from defects in workmanship and material for a period of 24 months for electronics and 12 months for mechanical parts and electrodes from date of delivery from the factory or authorized distributor under normal use and service and otherwise when such equipment is used in accordance with instructions furnished by WALCHEM Corporation and for the purposes disclosed in writing at the time of purchase, if any. WALCHEM Corporation's liability under this warranty shall be limited to replacement or repair, F.O.B. Holliston, MA U.S.A. of any defective equipment or part which, having been returned to WALCHEM Corporation, transportation charges prepaid, has been inspected and determined by WALCHEM Corporation to be defective. Replacement elastomeric parts and glass components are expendable and are not covered by any warranty.

THIS WARRANTY IS IN LIEU OF ANY OTHER WARRANTY, EITHER EXPRESS OR IMPLIED, AS TO DESCRIPTION, QUALITY, MERCHANTABILITY, and FITNESS FOR ANY PARTICULAR PURPOSE OR USE, OR ANY OTHER MATTER.

180272 Rev N
Jun 2008

TABLE OF CONTENTS



1.0	INTRODUCTION	1
2.0	SPECIFICATIONS	1
2.1	MEASUREMENT PERFORMANCE.....	1
2.2	ELECTRICAL	2
2.3	MECHANICAL	3
2.4	VARIABLES AND THEIR LIMITS	4
3.0	UNPACKING & INSTALLATION.....	8
3.1	UNPACKING THE UNIT	8
3.2	MOUNTING THE ELECTRONIC ENCLOSURE	8
3.3	INSTALLATION.....	8
3.4	ICON DEFINITIONS	12
3.5	ELECTRICAL INSTALLATION	16
4.0	FUNCTION OVERVIEW	23
4.1	FRONT PANEL.....	23
4.2	DISPLAY	23
4.3	KEYPAD.....	24
4.4	ACCESS CODES.....	24
4.5	INITIAL STARTUP.....	24
4.6	COMMUNICATING WITH THE WEBMASTERONE	26
4.7	STARTUP.....	32
4.8	SHUT DOWN	32
5.0	OPERATION – USING LOCAL DISPLAY AND KEYPAD.....	32
5.1	INPUT SUMMARY.....	32
5.2	INDICES	33
5.3	OUTPUT SUMMARY	33
5.4	ALARMS	33
5.5	CALIBRATION	33
5.6	RELAY CONTROL (HOA).....	38
5.7	SET POINTS.....	39
5.8	COMMUNICATION.....	42
5.9	ACCESS CODES.....	44
5.10	SOFTWARE UPGRADE	44
5.11	COPY TO USB DISK.....	45
5.12	FEATURE ACTIVATIONS.....	45
6.0	OPERATION – USING PC	45
6.1	MENU SELECTION LINKS	46
6.2	START UP MENU	46
6.3	SYSTEM SUMMARY MENU.....	51
6.4	SENSOR MENU - CONDUCTIVITY INPUT.....	51
6.5	SENSOR MENU - pH INPUT	54
6.6	SENSOR MENU - ORP INPUT	57
6.7	LEVEL (4-20 mA) INPUT MENU.....	60
6.8	FLOW METER (4-20 mA) INPUT MENU.....	60
6.9	GENERIC (4-20 mA) INPUT MENU	61

6.10	4-20 MA INPUT MENU.....	62
6.11	FLOW METER (DIGITAL) INPUT MENU.....	63
6.12	INTERLOCK MENU.....	64
6.13	POSIFLOW INPUT MENU.....	64
6.14	LEVEL SWITCHES (DIGITAL) INPUT MENU.....	65
6.15	GENERIC (DIGITAL) INPUTS MENU.....	66
6.16	COUNTER INPUTS MENU.....	66
6.17	DIGITAL INPUTS MENU.....	67
6.18	RELAY (1 – 8) OUTPUT MENUS – ON/OFF SET POINT TYPES.....	67
6.19	RELAY (1-8) OUTPUT MENUS – TIME PROPORTIONAL TYPES.....	70
6.20	RELAY (1 – 8) OUTPUT MENUS – CYCLES OF CONCENTRATION TYPES.....	72
6.21	RELAY (1 – 8) OUTPUT MENUS – INTERMITTENT (FIXED BLOWDOWN TIME) TYPES.....	74
6.22	RELAY (1 – 8) OUTPUT MENUS – INTERMITTENT (PROPORTIONAL BLOWDOWN TIME) TYPES.....	76
6.23	RELAY (1 - 8) OUTPUT MENUS – FLOW BASED FEED TYPE.....	79
6.24	RELAY (1-8) OUTPUT MENUS – FEED WITH ANOTHER RELAY TYPES.....	81
6.25	RELAY (1 – 8) OUTPUT MENUS – FEED AFTER ANOTHER RELAY (%) TYPES.....	83
6.26	RELAY (1-8) OUTPUT MENUS – FEED AFTER ANOTHER RELAY (FIXED TIME).....	85
6.27	RELAY (1 – 8) OUTPUT MENUS – FEED AS % OF TIME TYPES.....	86
6.28	RELAY (1 – 8) OUTPUT MENUS – BIOCIDES TIMER BASED TYPES.....	88
6.29	RELAY (1 – 8) OUTPUT MENUS – SPIKE SET POINT TYPES.....	91
6.30	RELAY (1 – 8) OUTPUT MENUS – DISPERSANT TYPES.....	94
6.31	RELAY (1-8) OUTPUT MENUS - BLEED VOLUME BASED ON MAKEUP VOLUME.....	95
6.32	RELAY 8 OUTPUT MENU – ALARM TYPE.....	97
6.33	ANALOG OUTPUT (1-4) MENU.....	99
6.34	LSI/RSI.....	100
6.35	DATA LOGGING.....	101
6.36	AUTO REPORTING.....	102
6.37	GRAPHING/TRENDING.....	103
6.38	COMMUNICATIONS MENU.....	103
6.39	ADVANCED COMMS.....	107
6.40	CONFIGURATION FILE MENU.....	109
6.41	NOTEPAD.....	110
6.42	ACCESS CODES.....	110
6.43	SOFTWARE UPGRADES (ONLY APPEARS IF A NEWER REVISION OF SOFTWARE IS AVAILABLE).....	111
6.44	SUB-NETWORK.....	111
7.0	MAINTENANCE.....	112
7.1	FLOW SWITCH CLEANING.....	112
7.2	CONDUCTIVITY SENSOR CLEANING AND CALIBRATION.....	114
7.3	pH ELECTRODE CLEANING AND CALIBRATION.....	115
7.4	ORP ELECTRODE CLEANING AND CALIBRATION.....	115
7.5	REPLACING THE FUSES.....	116
8.0	TROUBLESHOOTING.....	117
8.1	ERROR MESSAGES.....	117
8.2	PROBLEMS THAT DON'T GENERATE AN ERROR MESSAGE.....	132
8.3	CONNECTION PROBLEMS.....	134
9.0	SERVICE POLICY.....	135

1.0 INTRODUCTION

The WebMasterONE series controller is multi-functional, but not all of the features mentioned are necessarily present in the controller you have received. All features can be added in the field. The controller may be configured to control a cooling tower, or a boiler, or both.

Standard features include a direct sensor measurement of either conductivity, pH, or ORP; three digital inputs (for flow switch, metering pump flow feedback, counter, or other use), eight relay outputs, and both Ethernet and USB connections to a computer.

Optional features include:

Up to three additional pH, ORP and/or conductivity measurements.

Up to six digital inputs (for level switch, metering pump flow feedback, counter, or other use).

Up to eight 4-20 mA inputs (for drum level, flow meters, or practically any other parameter).

Up to four 4-20 mA outputs (for retransmission of the conductivity, pH, ORP, temperature or any 4-20 mA input signals).

A modem card (for remote communications)

The controller can log data and events, automatically generate reports on a periodic basis at a programmable frequency, and if equipped with a modem card, dial out in the event of an alarm condition. The alarm notification may be via phone to a pager, or email.

Our revolutionary digital communications package allows you to change set points, manually activate or deactivate pumps and valves, upgrade software, receive reports and alarms, *from any PC that has Internet access. No proprietary software needs to be installed on the PC, only a web browser.*

2.0 SPECIFICATIONS

2.1 Measurement Performance

Contacting Conductivity

Range 0-10,000 μ S/cm
Resolution 1 μ S/cm
Calibration \pm 50% of raw reading;
scalable to read in ppm

pH

Range -2 to 16 pH units
Resolution 0.01 pH units
Calibration single or dual point

mV

Range \pm 1400 mV
Resolution 1 mV
Calibration single or dual point

Temperature

Range 32 to 392 $^{\circ}$ F (0 to 200 $^{\circ}$ C)
Resolution 1 $^{\circ}$ F (1 $^{\circ}$ C)
Calibration single point; degrees C or F

Electrodeless Conductivity

Ranges 50 to 10,000 μ S/cm
Resolution 1 μ S/cm
Calibration single or dual point; scalable to read in ppm or % concentration

2.2 Electrical

Inputs

Input power 100 – 120/220-240 VAC \pm 10%, 12A, 50/60 Hz **Fuse** 1.6A, 5 x 20mm

Input signals **STANDARD**

Digital Inputs (A-C): Isolated dry contact (relay, reed switch or Hall Effect)
0-300 Hz, 1.5 msec minimum width

Input signals **OPTIONAL**

Digital Inputs (1-4) Isolated dry contact (relay, reed switch or Hall Effect)
0-10 Hz, 50 msec minimum width

Digital Inputs (5-6) Isolated dry contact (relay, reed switch or Hall Effect)
0-300 Hz, 1.5 msec minimum width

Point Level Switch: Isolated dry contact (relay, reed switch or Hall Effect)

Flow Feedback: Isolated dry contact (relay, reed switch or Hall Effect)

Analog Inputs (1-8) 4-20 mA, 2-wire or 3 -wire, internally powered by 24 VDC, 25 ohm input resistance,
1000 ohm maximum load.

Sensor **STANDARD (1)**

Signal (isolated) \pm 1.5V
Temp (isolated) 1K or 10K or 100K
ohm

Sensor **OPTIONAL (3)**

Signal (isolated) \pm 1.5V
Temp (isolated) 1K or 10K or 100K ohm

Outputs

STANDARD

Mechanical relays: At 115 VAC, 10 amp (resistive), 1/8 HP
At 230 VAC, 6 amp (resistive), 1/8 HP

R1, R2, R3, and R4 relays are fused together as one group, total current for this group must not exceed 5.5A

R5, R6, R7 and R8 relays are fused together as one group, total current for this group must not exceed 5.5A.

Relays 1-8 may be dry contact or may switch line (mains) voltage, depending upon model code; refer to Figure 4. Powered relays have both NO and NC terminals available. Only powered relays are fused.

Digital: USB
Ethernet, 10 Base T

OPTIONAL

4-20 mA (1-4): Isolated, 500 ohm max. resistive load, internally powered

Agency Approvals

UL ANSI/UL 61010-1:2004, 2nd Edition *

CAN/CSA C22,2 No.61010-1:2004, 2nd Edition *

CE Safety EN 61010-1 2nd Edition (2001) *

CE EMC EN 61326 :1998 Annex A *

Note: For EN61000-4-3,-6 the controller met performance criteria B.

* Equipment suitable for use in establishments other than domestic, and those directly connected to a low voltage (100-240 VAC) power supply network which supplies buildings used for domestic purposes.

2.3 Mechanical

Enclosure

Material:	Molded Fiberglass
NEMA Rating:	NEMA 4X
Dimensions:	10" x 12" x 5-5/8" (25.4cm x 30.5cm x 14.5cm)
Display:	64 x 128 Pixel Backlit LCD Graphics Module
Operating Ambient Temp:	0 to 49° C (32-120°F)
Storage Temp:	-29 to 80°C
Weight	11.5lb (5.2kg)

Flow switch manifold

Pressure:	150 psi up to 100° F, 50 psi @140° F
Temperature:	0 to 140°F
Process connections:	¾" NPTF
Wetted Materials of construction:	Glass-Filled Polypropylene, PVC, FKM, Isoplast

pH Electrode

Pressure:	0 to 100 psi
Temperature:	50 to 158°F
Process connections:	¾" NPTF
Wetted Materials of Construction:	Glass-Filled Polypropylene, CPVC, HDPE, FKM, Glass

ORP electrode

Pressure:	0 to 100 psi
Temperature:	32 to 158°F
Process connections:	¾" NPTF
Wetted Materials of Construction:	Glass-Filled Polypropylene, CPVC, HDPE, FKM, Platinum, Glass

Contacting conductivity electrode

Pressure:	0 to 150 psi
Temperature:	32 to 158°F
Process connections:	¾" NPTF
Wetted Materials of Construction:	Glass-Filled Polypropylene, Graphite, FKM

Electrodeless conductivity sensor

Pressure:	0 to 150 psi
Temperature:	32 to 158°F
Process connections:	¾" NPTF
Wetted Materials of Construction:	Glass-Filled Polypropylene, CPVC, FKM

Stainless steel contacting conductivity electrode

Pressure:	0-150 psi
Temperature:	32-158F
Process connections:	¾" NPTF
Wetted Materials of Construction:	Glass-Filled Polypropylene, 316 SS, FKM

High pressure tower contacting conductivity electrode

Pressure:	0-300 psi
Temperature:	32-158F
Process connections:	¾" NPTM
Wetted Materials of Construction:	316 SS, PEEK

High pressure boiler contacting conductivity electrode

Pressure:	0-250 psi
Temperature:	32-392F
Process connections:	¾" NPTM
Wetted Materials of Construction:	316 SS, PEEK

High pressure pH electrode

Pressure:	0-300 psi
Temperature:	32-275F
Process connections:	½" NPTM
Wetted Materials of Construction:	Glass, Polymer, PTFE, 316 SS, FKM

High Pressure ORP electrode

Pressure:	0-300 psi
Temperature:	32-275F
Process connections:	1/2" NPTM
Wetted Materials of Construction:	Platinum, Polymer, PTFE, 316 SS, FKM

High Pressure flow switch

Pressure:	0-300 psi
Temperature:	32-158F
Process connections:	¾" NPTF
Wetted Materials of Construction:	Carbon steel, Brass, 316SS, FKM"

2.4 Variables and their Limits

All menus shown may not be available. The menus that appear on your controller will vary with options installed and programmed.

Sensor Input Menu – if Contacting Conductivity

Calibration Reminder	0 – 365 days
ppm Conversion Factor	0.5 – 1.0
Low Alarm Limit	0 to 10,000 (units defined by user)
High Alarm Limit	0 to 30,000 (units defined by user)
Temperature Low Alarm Limit	0 – 158 degrees
Temperature High Alarm Limit	0 – 158 degrees

Sensor Input Menu – if High Temp Contacting Conductivity

Calibration Reminder	0 – 365 days
ppm Conversion Factor	0.5 – 1.0
Low Alarm Limit	0 to 10,000 (units defined by user)
High Alarm Limit	0 to 30,000 (units defined by user)
Temperature Low Alarm Limit	32 – 392 degrees F
Temperature High Alarm Limit	32 – 392 degrees F

Sensor Input Menu – if Electrodeless Conductivity

Calibration Reminder	0 – 365 days
ppm Conversion Factor	0.5 – 1.0
Low Alarm Limit	0 to full scale of range
High Alarm Limit	0 to full scale of range
Temperature Low Alarm Limit	0 – 158 degrees
Temperature High Alarm Limit	0 – 158 degrees

Sensor Input Menu – if pH

Calibration Reminder	0-365 days
High Alarm Limit	-2 to 16
Low Alarm Limit	-2 to 16
Temperature Low Alarm Limit	0 – 158 degrees
Temperature High Alarm Limit	0 – 158 degrees

Sensor Input Menu – if ORP

Calibration Reminder	0-365 days
High Alarm Limit	-1400 to 1400 mV
Low Alarm Limit	-1400 to 1400 mV

Flowmeter Input Menu – Analog Input Type

Flow Rate at 4 mA	0 to 1000 (units of measure defined by user)
Flow Rate at 20 mA	0 to 1000 (units of measure defined by user)

Level Input Menu – Analog Input Type

Empty mA	0 to 20 mA
Full mA	0 to 20 mA
Full volume	0 to 10,000 (units defined by user)
Low Level Alarm Limit	0.001 to 10,000 (units defined by user)

Generic 4-20 mA Input Menu

Parameter = 4 mA	-10,000 to 10,000 (units defined by user)
Parameter = 20 mA	-10,000 to 10,000 (units defined by user)
Low Alarm Limit	-100,000,000 to 100,000,000 (units defined by user)
High Alarm Limit	-100,000,000 to 100,000,000 (units defined by user)

Flowmeter Input Menu – Digital Input Type

Volume per Contact	0 to 1000 (units of measure defined by user)
K Factor	0.001 to 20,000 (Pulses per Gallon or Liter)
Total Alarm Limit	0 = no limit, otherwise >0
Rate High Alarm	>0
Rate Low Alarm	>0

PosiFlow Input Menu

Alarm Time	0.1 to 10 minutes
Pump Volume per Stroke	0.000 to 100 (units of measure defined by user)

Counter Input Menu

One Count =	>0
Total Alarm Limit	0 =no limit, otherwise >0
Rate High Alarm	>0
Rate Low Alarm	>0

Relay Output Menu – On/Off Set Point

Set Point	Full scale range of the input parameter
Dead Band	Full scale range of the input parameter
Output Time Limit	0 = ∞, 1 to 1440 minutes
Hand Time Limit	0 = ∞, 1 to 1440 minutes

Relay Output Menu – Time Proportional

Set Point	Full scale range of the input parameter
Sample Period	1 to 1440 minutes
Proportional Band	Full scale range of the input parameter
Output Time Limit	0 = ∞, 1 to 1440 minutes
Hand Time Limit	0 = ∞, 1 to 1440 minutes

Relay Output Menu – Feed with Another Relay

Output Time Limit	0 = ∞, 1 to 1440 minutes
Hand Time Limit	0 = ∞, 1 to 1440 minutes

Relay Output Menu – Feed after Another Relay (Fixed Time)

Fixed Time to Feed	0 to 1440 minutes
Hand Time Limit	0 = ∞, 1 to 1440 minutes

Relay Output Menu – Flow Based Feed

Volume to trigger Feed	1 to 99,999 (units defined by user)
Feed Time per unit Volume	1 second to 1440 minutes
Output Time Limit	0 = ∞, 1 to 1440 minutes
Hand Time Limit	0 = ∞, 1 to 1440 minutes

Relay Output Menu – Biocide Timer Based

Output On-Time	1 to 1440 min
Hand Time Limit	0 = ∞, 1 to 1440 minutes

Relay Output Menu – Feed After Another Relay (%)

% of Relay to Feed	0 to 100%
Output Time Limit	0 = ∞, 1 to 1440 minutes
Hand Time Limit	0 = ∞, 1 to 1440 minutes

Relay Output Menu – Feed as % Time

Time Period	1 – 1440 minutes
% of Period to Feed	0.1 to 100%
Output Time Limit	0 = ∞, 1 to 1440 minutes
Hand Time Limit	0 = ∞, 1 to 1440 minutes

Relay Output Menu – Cycles of Concentration

Cycles Set Point	1 – 50 cycles
Cycles Dead band	0.01 – 20 cycles
Cycles Low Alarm	0 – 50 cycles
Cycles High Alarm	0 – 50 cycles
Output Time Limit	0 = ∞, 1 to 1440 minutes
Hand Time Limit	0 = ∞, 1 to 1440 minutes

Relay Output Menu – Spike

Set Point	Full scale range of the parameter
Dead Band	Full scale range of the parameter
Relay On-Time	1 sec to 1440 minutes
Hand Time Limit	0 = ∞, 1 to 1440 minutes

Relay Output Menu – Intermittent, Fixed Blowdown Time

Set Point	Full scale range of the parameter
Interval Time	5 to 1440 minutes
Duration of Sample	10 seconds to 60 minutes
Hold Time	30 seconds to 10 minutes
Blowdown Time	1 to 1440 minutes
Hand Time Limit	0 = ∞, 1 to 1440 minutes

Relay Output Menu – Intermittent, Proportional Blowdown Time

Set Point	Full scale range of the parameter
Interval Time	5 to 1440 minutes
Duration of Sample	10 seconds to 60 minutes
Hold Time	30 seconds to 10 minutes
Blowdown Time	1 to 1440 minutes
Hand Time Limit	0 = ∞, 1 to 1440 minutes

Relay Output Menu - Diagnostic Alarm

Remote Alarm Delay Time	0 to 1440 minutes
Output Time Limit	0 = ∞, 1 to 1440 minutes
Hand Time Limit	0 = ∞, 1 to 1440 minutes

4-20 mA Output Menus

(parameter selected) = 4 mA	Full scale range of the parameter
(parameter selected) = 20 mA	Full scale range of the parameter

Full Scale Ranges are:

Contacting Conductivity:	0 to 10,000 $\mu\text{S}/\text{cm}$
Electrodeless Conductivity:	50 to 10,000 $\mu\text{S}/\text{cm}$
Or	10 mS/cm to 100 mS/cm
Or	100 mS/cm to 1000 mS/cm
Temperature:	-18 to 200 degrees C
pH:	-2 to 16 standard units
ORP:	-1400 to 1400 mV

Data Logging Menu

Logging Interval

10 to 1440 minutes

3.0 UNPACKING & INSTALLATION

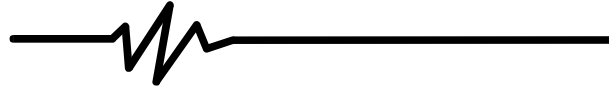

3.1 Unpacking the Unit

Inspect the contents of the carton. Please notify the carrier immediately if there are any signs of damage to the controller or its parts. Contact your distributor if any of the parts are missing. The carton should contain a WebMasterONE and technical support package (contains instruction manual, Quick Start Guide, CD and USB cable). Any options or accessories will be incorporated as ordered.

3.2 Mounting the Electronic Enclosure

The WebMasterONE is supplied with mounting holes on the enclosure. It should be wall mounted with the display at eye level on a vibration-free surface, utilizing all mounting holes for maximum stability.

The enclosure is NEMA 4X rated, suitable for outdoor installation. The maximum ambient operating temperature is 120 degrees F (49 degrees C); this should be considered if installation is in a high temperature location.

The installation site should be in close proximity to grounded AC power, the chemistry to be controlled, and phone line or Ethernet hub (if applicable).

Avoid locations that are in close proximity to sources of electrical noise (motor starters, power transformers, variable speed motor drives, radio transmitters, etc.), corrosive fumes or excessive moisture.

The enclosure requires the following clearances:

Top:	2"
Left:	10"
Right:	4"
Bottom:	8"

3.3 Installation

Plumbing

The WebMasterONE series controllers are supplied with a flow switch manifold designed to provide a continuously flowing sample of cooling water to the sensors. Please refer to Figures 1 (a-d) below for some typical installation drawings.

Cooling Towers:

Tap off the discharge side of the recirculation pump to provide a minimum flow of 1 gallon per minute through the flow switch manifold. The sample must flow into the bottom of the manifold in order to close the flow switch, and return to a point of lower pressure in order to ensure flow. Install an isolation valve on both sides of the manifold to stop flow for sensor maintenance.

IMPORTANT: To avoid damaging the female pipe threads on the supplied plumbing parts, use no more than 3 wraps of PTFE tape and thread into the pipe **FINGER** tight only! **DO NOT** use any pipe dope, plumber's putty or other sealing products that contain diacetone alcohol, as these attack the flow switch plastic! Use PTFE tape **ONLY!**

Boilers:

The conductivity probe should be placed as close to the controller as possible, to a maximum distance of 250 ft. The cable **MUST** be shielded from background electrical noise. Use 24 AWG, 3 twisted pair, shielded, low capacitance (15 pF/ft) cable such as Walchem P/N 102535 (Belden 9680) or equivalent.

Important Boiler Installation Notes: (see figure 1b and c)

- 1. Make sure the minimum water level in the boiler is at least 4-6 inches above the skimmer blowdown line. If the skimmer line is closer to the surface, it is likely that steam will be drawn into the line instead of boiler water. The skimmer line must also be installed above the highest tube.**
- 2. Maintain a 3/4 inch minimum pipe ID with no flow restrictions from the tap for the boiler skimmer blowdown line to the electrode. If the ID is reduced below 3/4 inch, then flashing will occur beyond that point and the conductivity reading will be low and erratic. Minimize the usage of tees, valves, elbows or unions between the boiler and the electrode.**
- 3. A manual shut off valve should be installed so that the electrode can be removed and cleaned. This valve must be a full port valve in order to avoid a flow restriction. Keep the distance between the tap for the boiler skimmer line to the electrode as short as possible, to a maximum of 10 feet.**
- 4. Mount the electrode in the side branch of a tee in a horizontal run of pipe. This will minimize entrapment of steam around the electrode and will allow any solids to pass through.**
- 5. There MUST be a flow restriction after the electrode and/or control valve in order to provide back pressure. This flow restriction will be either a flow control valve or an orifice union. The amount of the flow restriction will affect the blowdown rate as well, and should be sized accordingly.**
- 6. Install the motorized ball valve or solenoid valve per the manufacturer's instructions.**
- 7. For best results, align the hole in the conductivity electrode such that the direction of water flow is through the hole.**

Guide to Sizing Blowdown Valves and Orifice Plates

1. Determine the Rate of Steam Production in Pounds per Hour:

Either read off the boiler name plate (water-tube boilers) or Calculate from horsepower rating (fire-tube boilers):

HP x 34.5 = lbs/hr. Example: 100 HP = 3450 lbs/hr.

2. Determine the Concentration Ratio (BASED ON FEEDWATER)

A water treatment chemical specialist should determine the desired number of cycles of concentration.

This is the ratio of TDS in the boiler water to TDS in the feedwater. Note that feedwater means the water that is fed to the boiler from the deaerator and includes makeup water plus condensate return.

Example: 10 cycles of concentration has been recommended

3. Determine the Required Blowdown Rate in Pounds Per Hour

Blowdown Rate = Steam Production / (Concentration Ratio - 1)

Example: $3450 / (10 - 1) = 383.33$ lbs./hr

4. Determine if Continuous or Intermittent Sampling is Required

Use intermittent sampling when the boiler operation or loading is intermittent, or on boilers where the required blowdown rate is less than 25% of the smallest available flow control valve or less than the flow through the smallest orifice. See the graphs on the next page.

Use continuous sampling when the boiler is operating 24 hours per day and the required blowdown rate is more than 25% of the smallest applicable flow control valve or orifice. See the graphs on the next page.

Use of a flow control valve will give you the best control of the process, since the flow rate can be easily adjusted. The dial on the valve also gives you a visual indication if the flow rate has been changed. If the valve clogs, it can be opened to clear the obstruction, and closed to the previous position.

If an orifice plate is used, you must install a valve downstream from the orifice in order to fine tune the flow rate and provide additional back pressure in many applications.

Example: An 80 psi boiler has a Required Blowdown Rate of 383.33 lbs./hr. The maximum flow rate of the smallest flow control valve is 3250 lbs./hr. $3250 \times 0.25 = 812.5$ which is too high for continuous sampling. Using an orifice, the flow rate through the smallest diameter plate is 1275 lbs./hr. This is too high for continuous sampling.

5. Determine the Orifice or Flow Control Valve Size for this Blowdown Rate

Use the following graphs to select a flow control device:

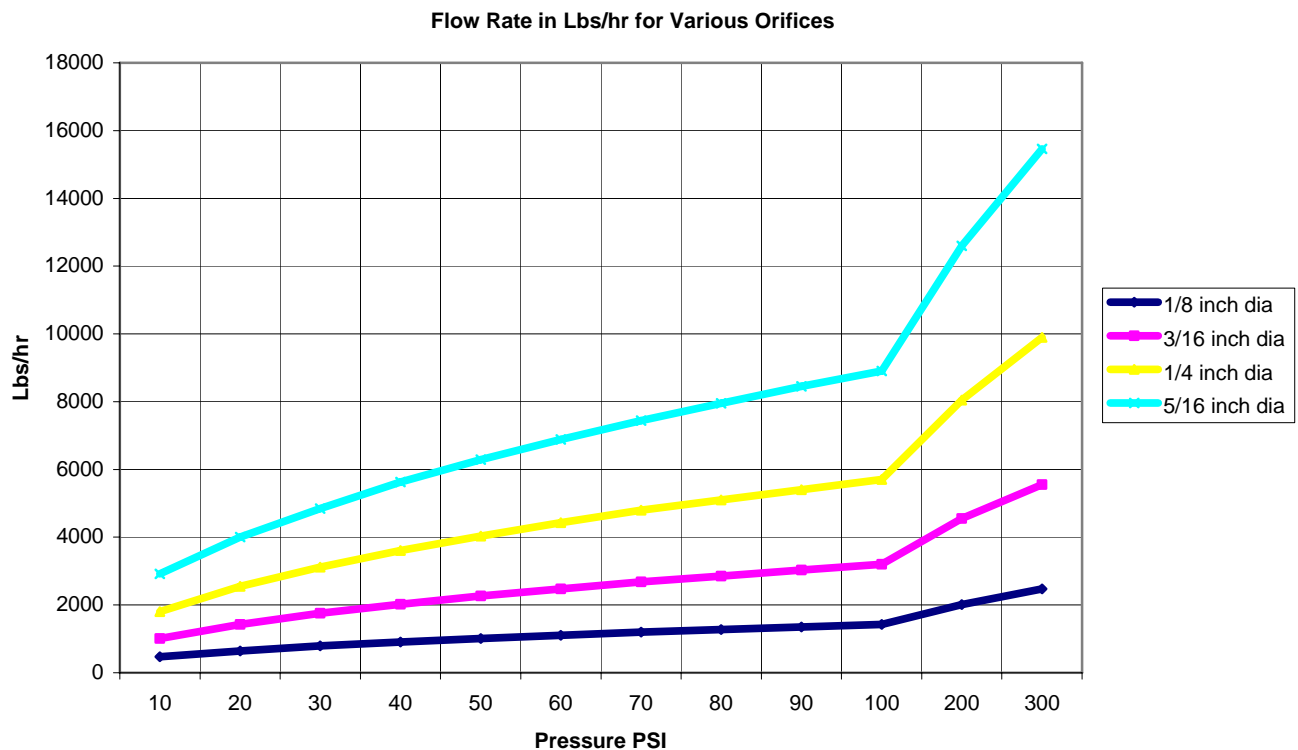

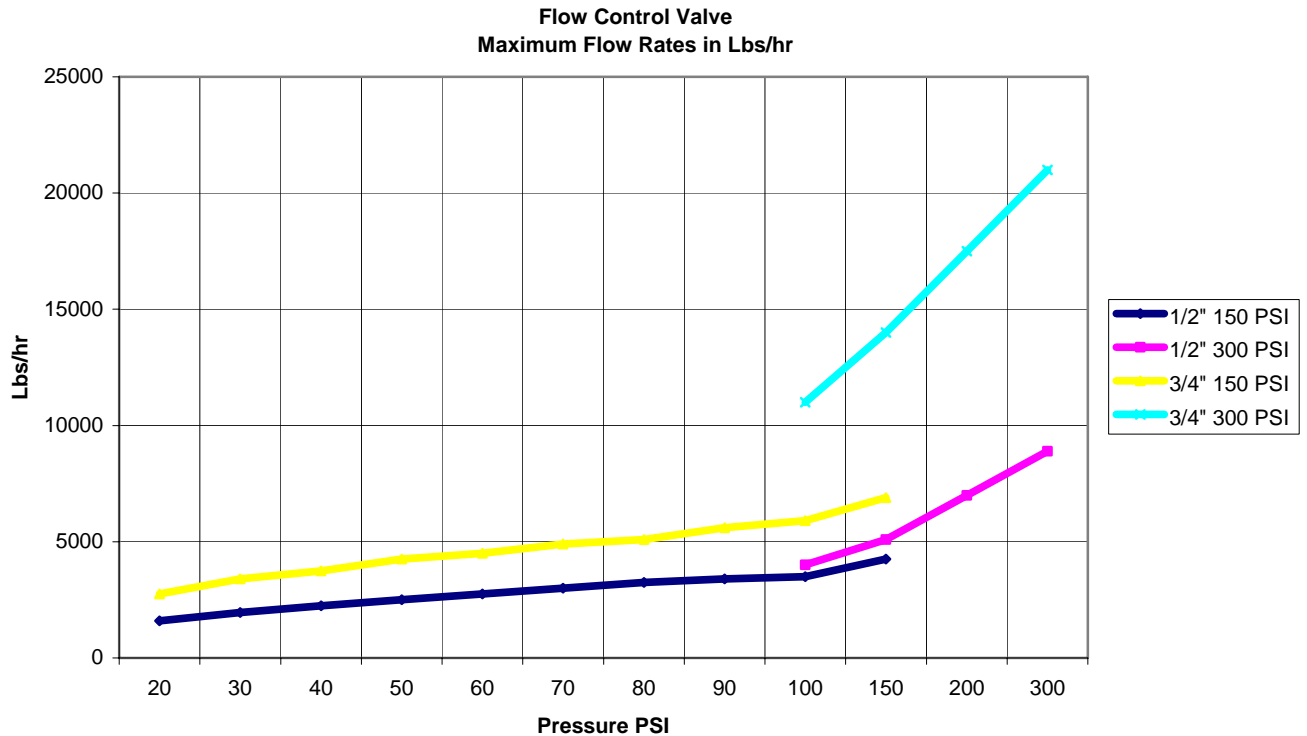

Sensor Installation

All sensors for the WebMasterONE series are provided with signal conditioning electronics, and conductivity sensors may be located up to 250 feet (75 meters) from the controller, and pH/ORP sensors may be located up to 1000 feet (303 meters) from the controller. It is highly recommended that the sensors be installed within 20 feet of the controller in order to make periodic calibration more convenient.







Sensors should be located such that they respond rapidly to a well-mixed sample of the process water and the treatment chemicals. If they are too close to the chemical injection point, they will see spikes in concentration and cycle on and off too frequently. If they are too far away from the chemical injection point, they will respond too slowly to the concentration changes, and you will overshoot the set point.

If the sensor cables need to be extended, then 24 AWG shielded low capacitance (15 pF/ft) twisted pair cable such as Walchem P/N 102535 (Belden 9680) or equivalent should be used. Pay attention to the integrity of the cable shield. Always route sensor cables (or any other low voltage wiring) in conduit that is separated from any AC voltage wiring by at least 6 inches.

pH and ORP electrodes must be installed such that the measuring surfaces will always remain wet. A U-trap provided in the manifold design should achieve this, even if the sample flow stops. These electrodes also must be installed with the measuring surfaces pointing down; that is 5 degrees above the horizontal, at a minimum.

If the sensors are to be submersed in the process, mount them firmly to the tank, and protect the cable with plastic pipe, sealed at the top with a cable gland, to prevent premature failure. Place the sensors in an area of good solution movement.

3.4 Icon Definitions

Symbol	Publication	Description
	IEC 417, No.5019	Protective Conductor Terminal
	IEC 417, No. 5007	On (Supply)
	IEC 417, No. 5008	Off (Supply)
	ISO 3864, No. B.3.6	Caution, risk of electric shock
	Pending	Caution, High temperature, risk of burn
	ISO 3864, No. B.3.1	Caution

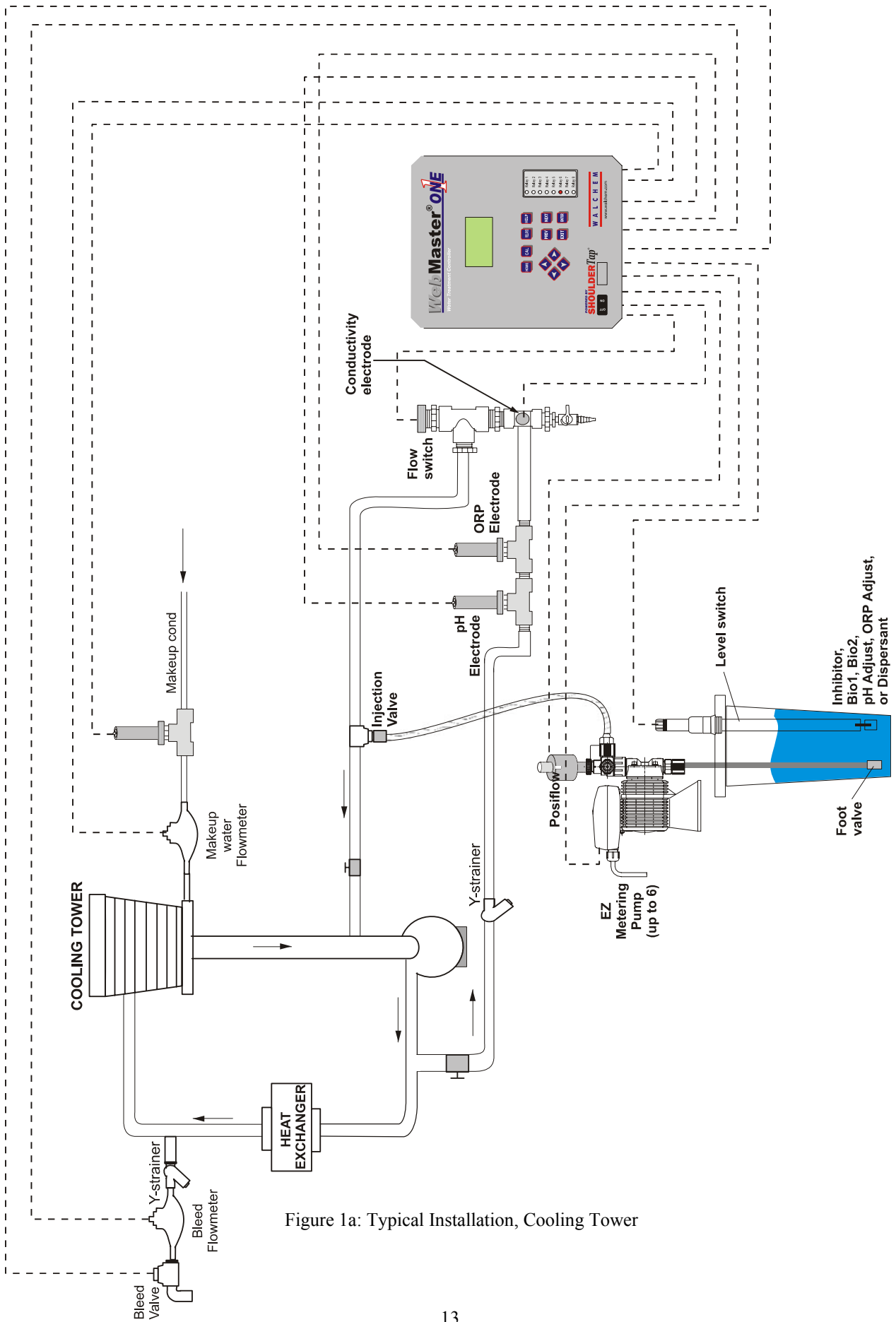

Figure 1a: Typical Installation, Cooling Tower

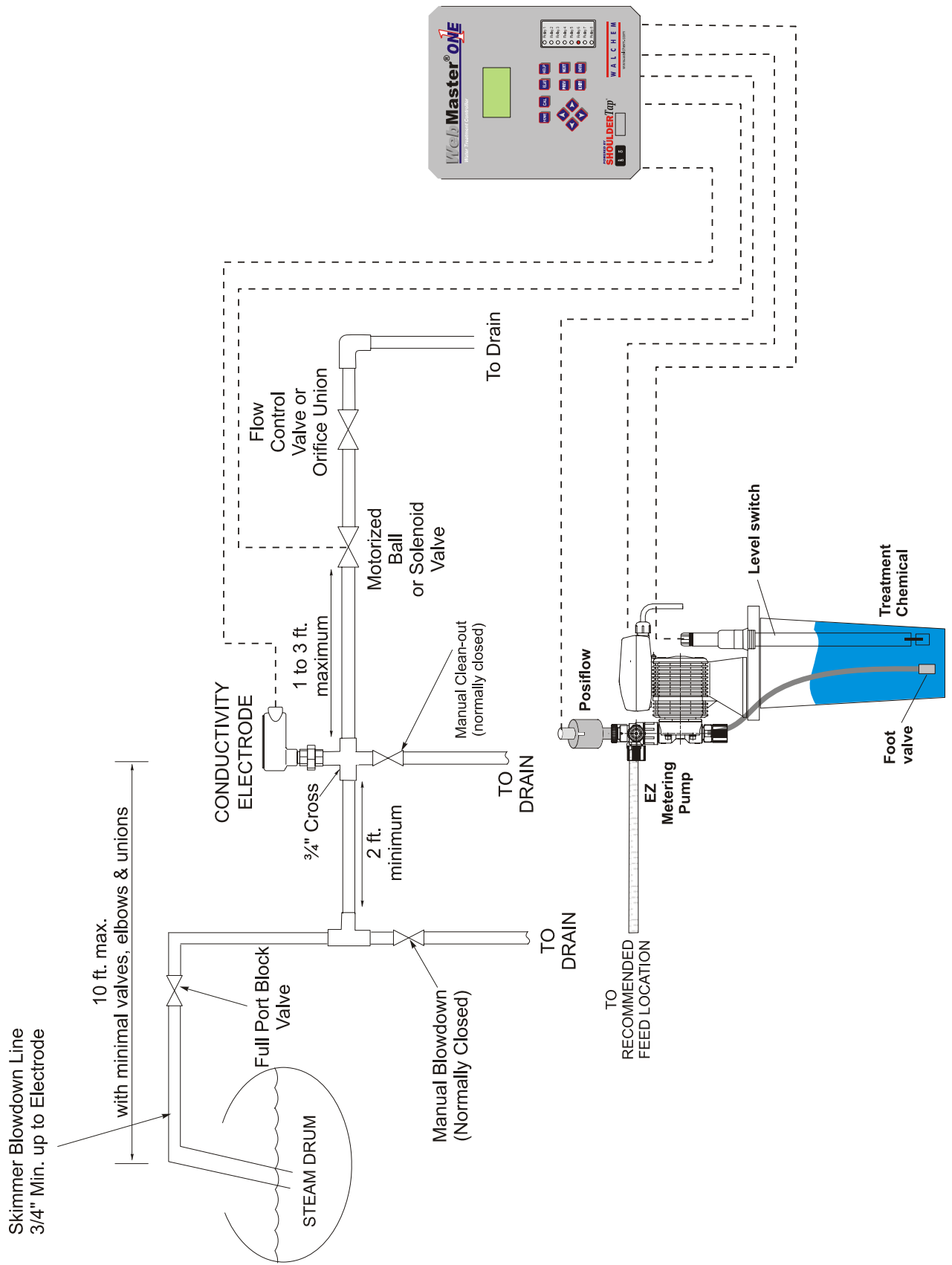

Figure 1b Typical Installation, Boiler Intermittent Sampling

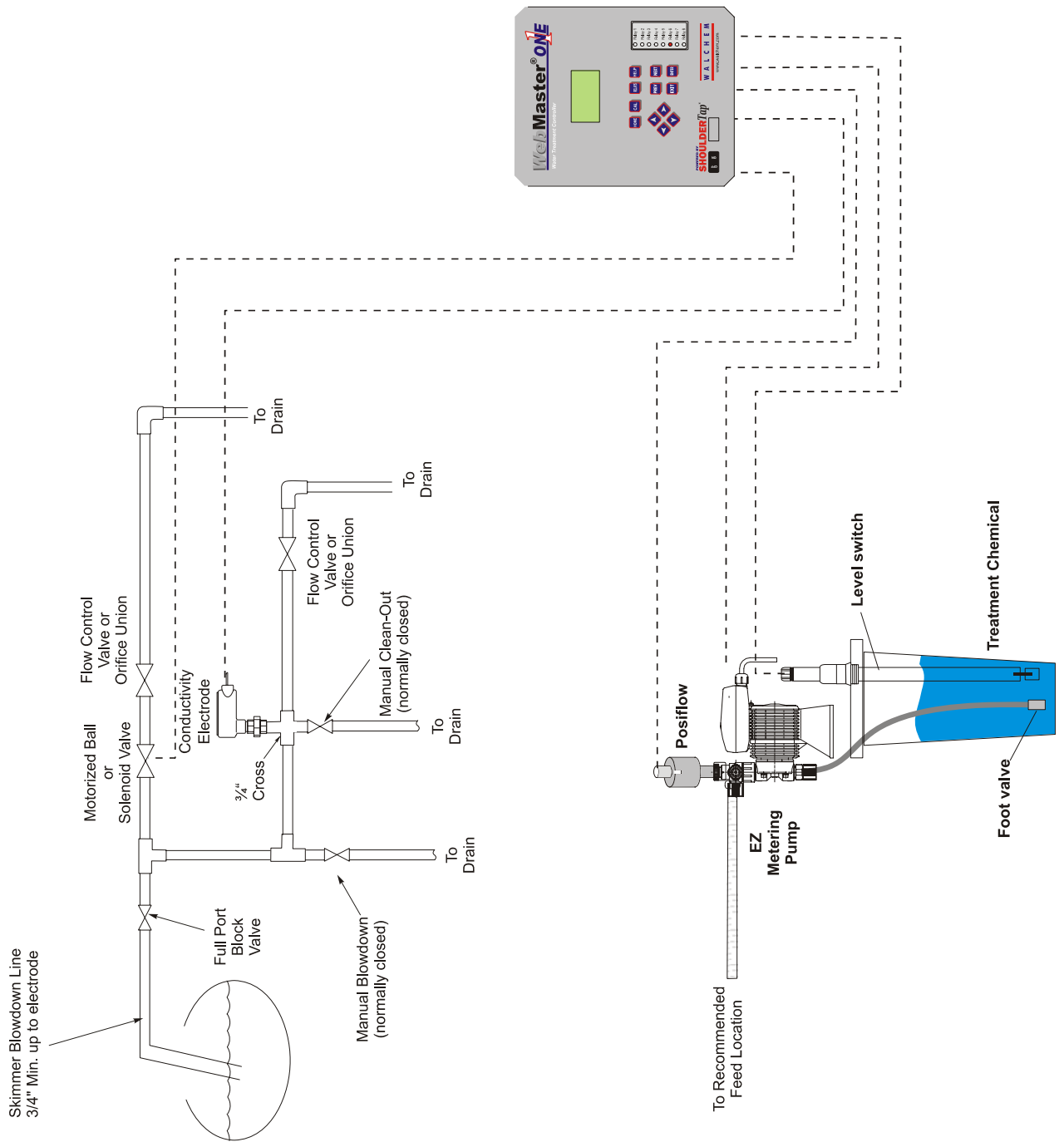

Figure 1c: Typical Installation, Boiler Continuous Sampling

3.5 Electrical Installation

The WebMasterONE series controllers require the following voltages:
100 –120/200-240 VAC± 10%, 50/60 Hz, 12 amperes maximum

The controller must be connected to its own 15 ampere breaker, close by, to act as an alternate power shutdown.

Your controller is supplied either factory prewired or ready to be hardwired. Depending upon your choice of options, you may be required to hardwire some or all of the input/output devices. Please refer to Figures 4 through 8 for wiring diagrams.

The output loads may be connected to pigtail (125V prewired) connections or terminal block (hardwired) connections. The total output current must not exceed 11 amps. The output relays are connected in two relay banks each fused at 6.3 amps. See figure on the right. Assess the steady state amps of all loads before connecting to controller. Depending upon your model code, some relays may be dry contact and not fused.

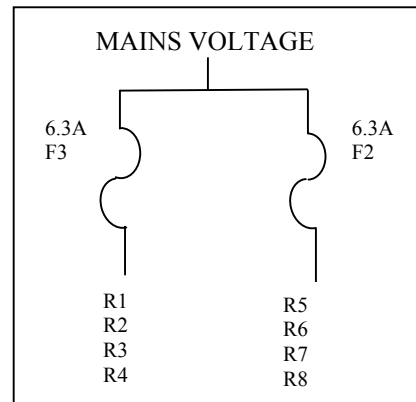

CAUTION! There are live circuits inside the controller even when the power switch on the front panel is in the OFF position! The front panel must never be opened before power to the controller is REMOVED!

If your controller is prewired, it is supplied with a 10 foot, 14 AWG power cord with USA style plug and 8 inch, 18 AWG USA style receptacle cords for the powered relay outputs. A tool (#1 Phillips driver) is required to open the front panel.



CAUTION! The electrical installation of the controller must be done by trained personnel only and conform to all applicable National, State and Local codes!

Note: Many of the inputs and outputs listed are optional and may not be present in your controller.

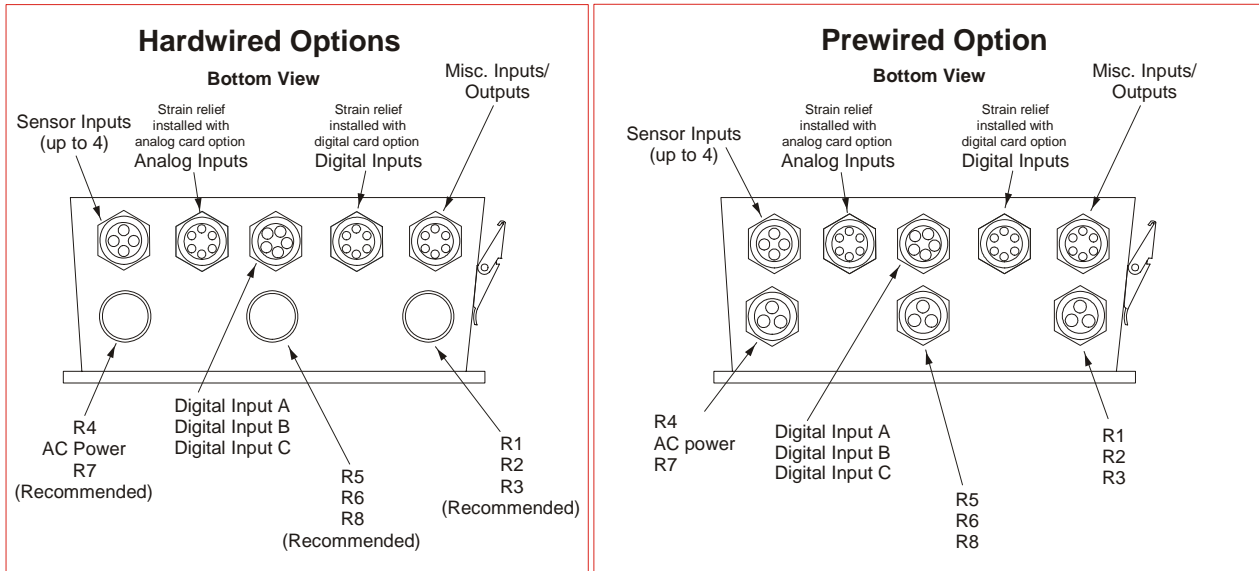

Figure 2: Conduit/Wiring Configuration

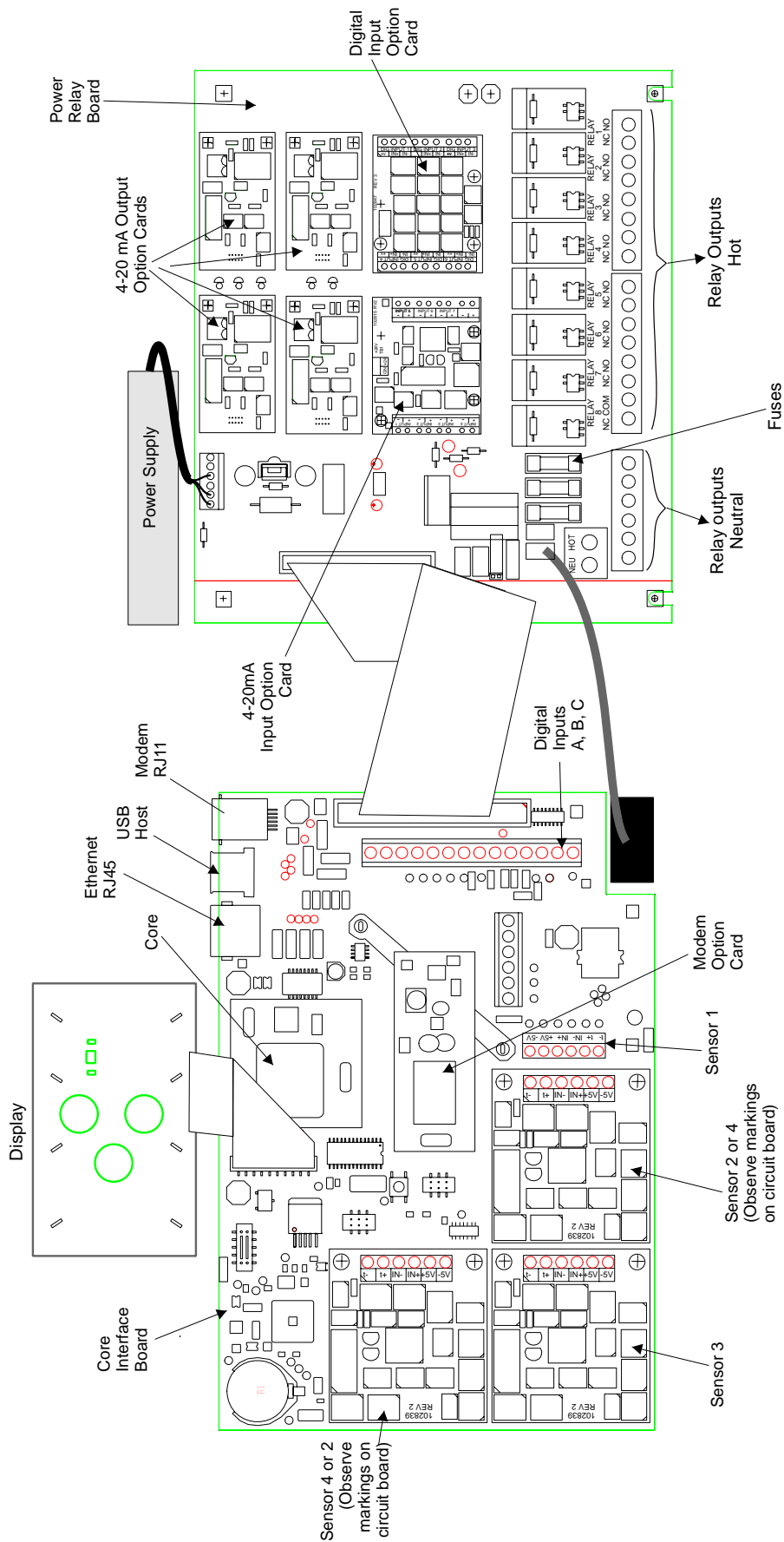

Figure 3 Identification of Parts

VoltageCode	R1	R2	R3	R4	R5	R6	R7	R8
0 or 4	DRY	DRY	DRY	DRY	DRY	DRY	DRY	DRY
1 or 6	POWERED	POWERED	POWERED	POWERED	POWERED	POWERED	POWERED	DRY
2 or 5	POWERED	POWERED	POWERED	POWERED	POWERED	POWERED	POWERED	POWERED
3 or 7	DRY	POWERED	DRY	POWERED	DRY	POWERED	DRY	POWERED

DRY CONTACTS WILL BE LABELED COM INSTEAD OF NC.

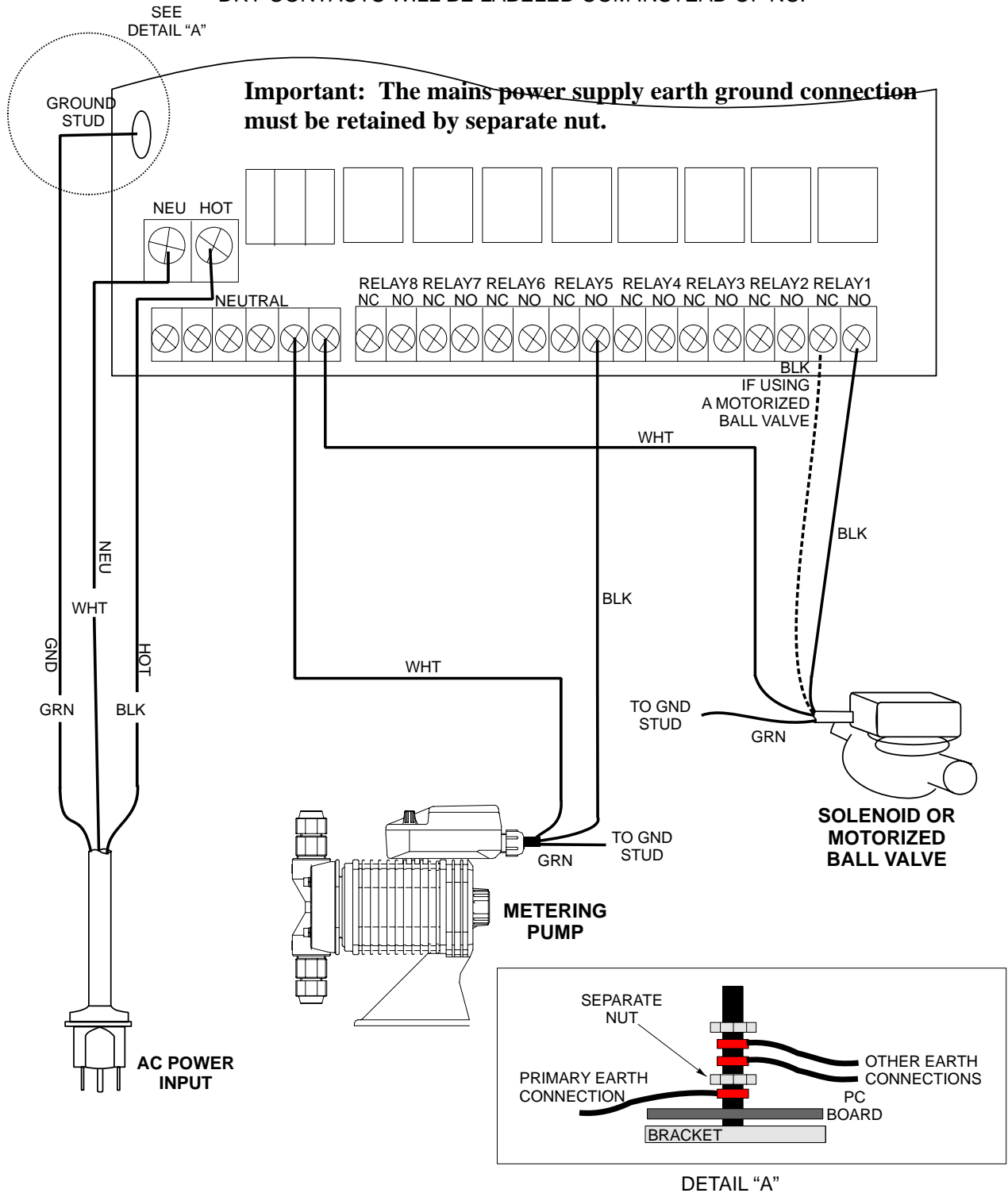

Figure 4: Wiring Diagram for AC Power Input and Relay Outputs

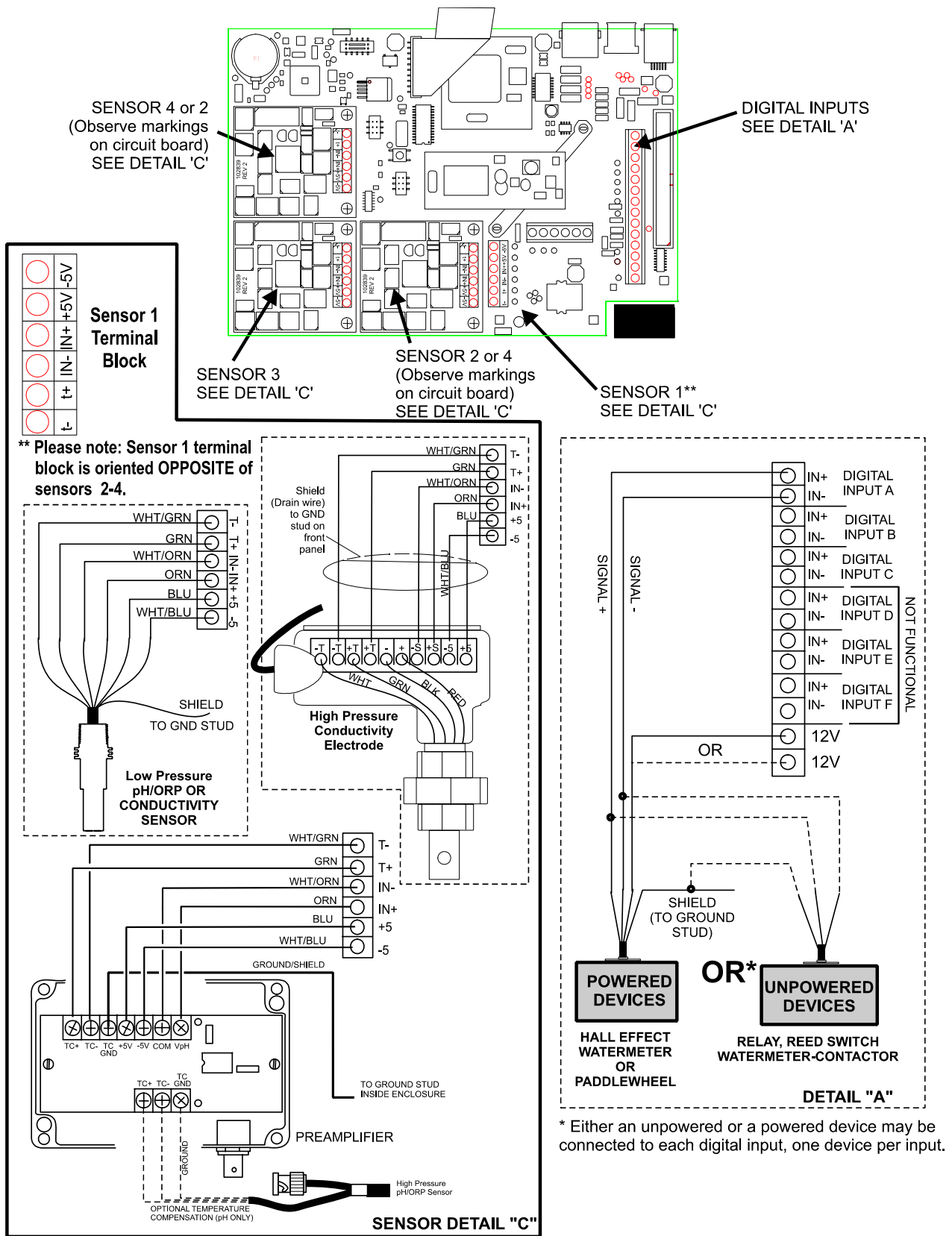
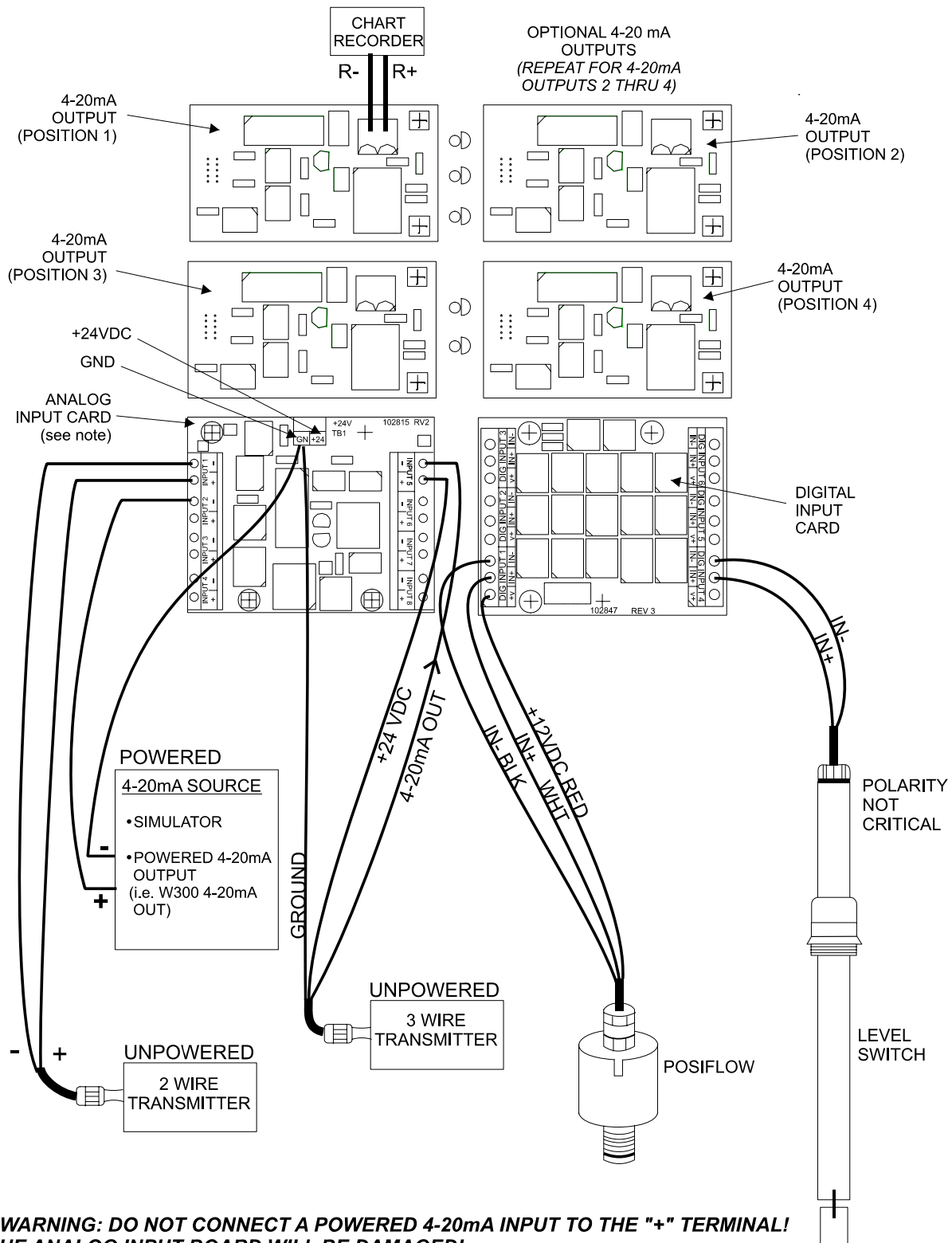

Figure 5: Wiring Diagram for Sensor Inputs and Digital Inputs A-C



Note: The analog input card is group isolated. Do not connect more than one non-isolated transmitter without installing a signal isolator!

Figure 6: Wiring Diagram for Optional Digital Inputs, 4-20 mA Inputs and 4-20 mA Outputs

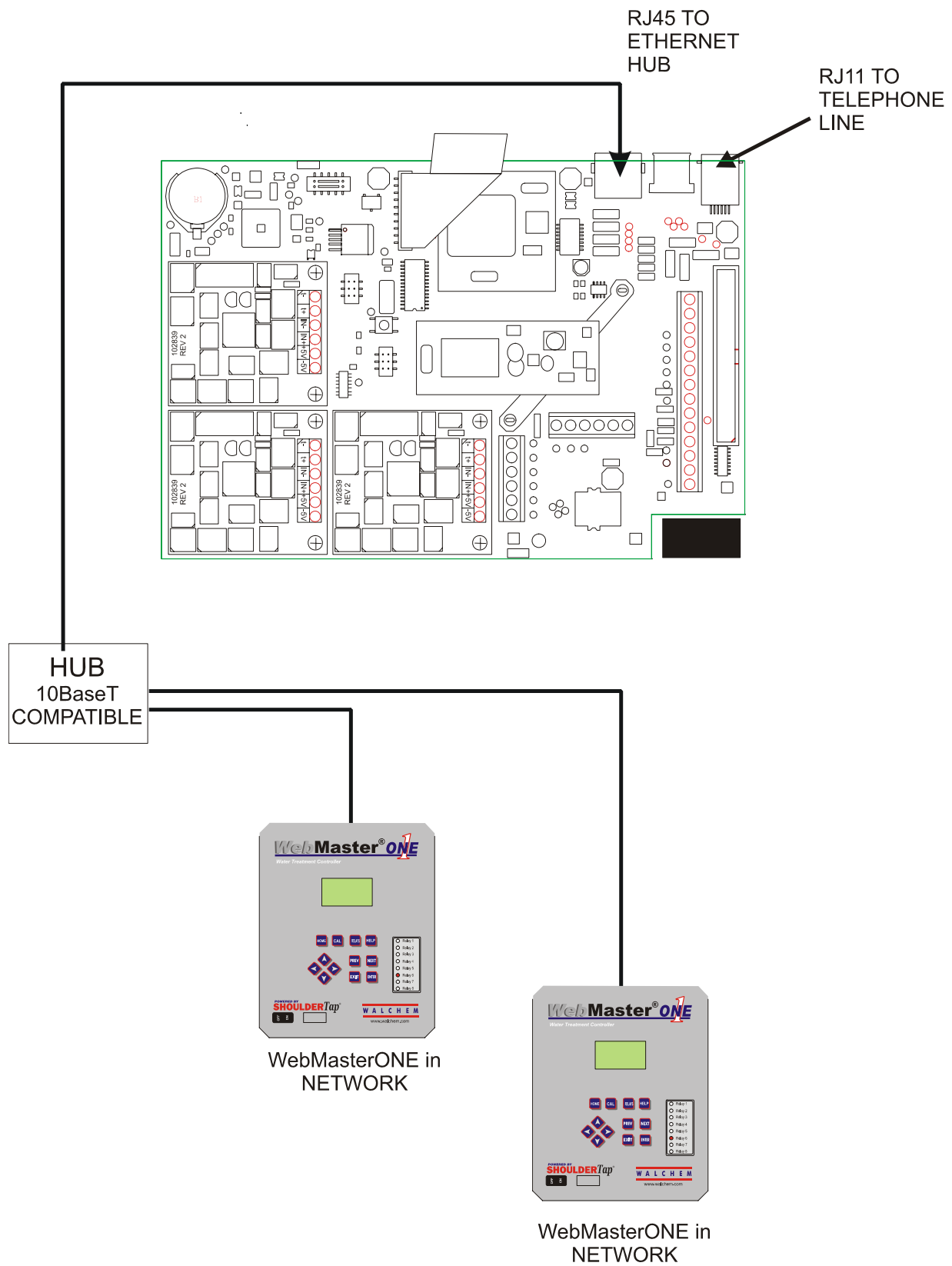
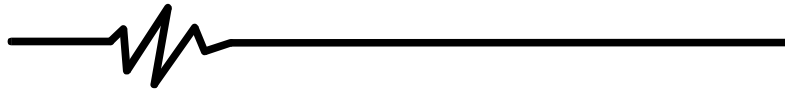

Figure 7: Wiring Diagram for Optional Digital Communications

4.0 FUNCTION OVERVIEW



4.1 Front Panel

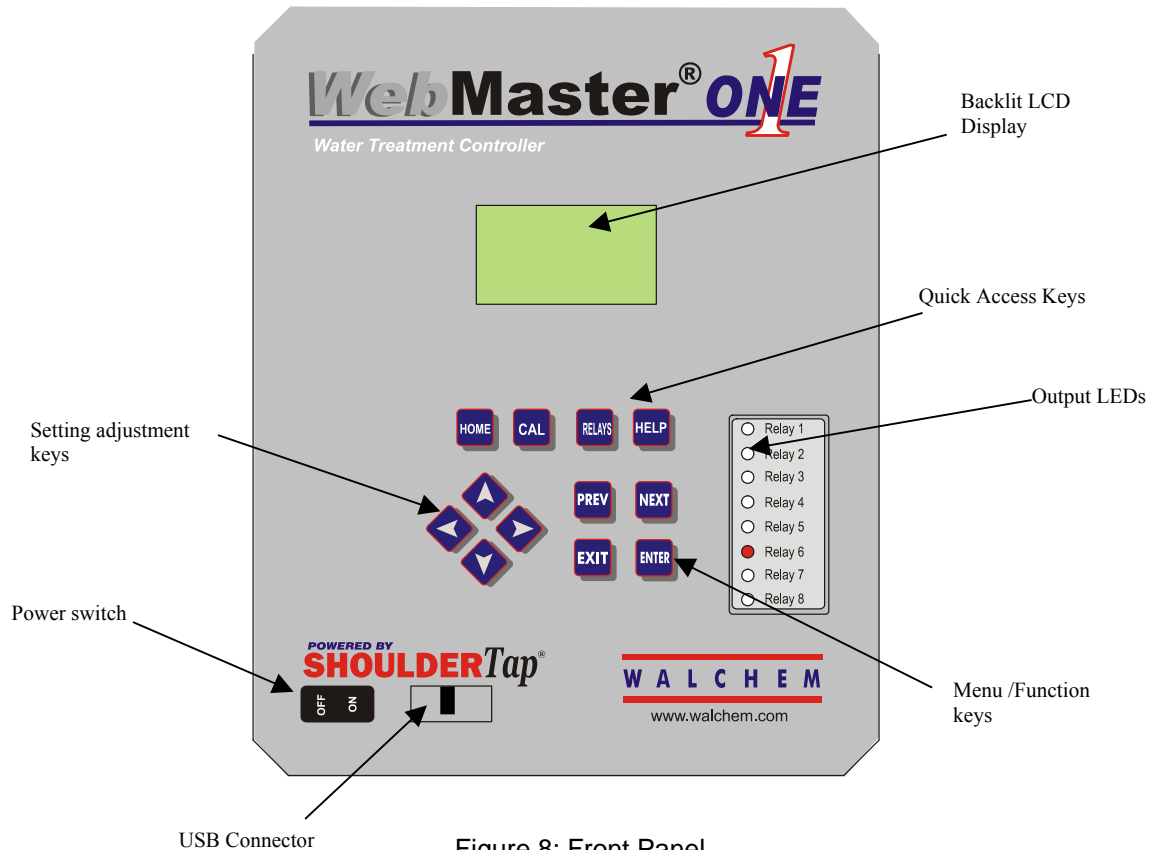

Figure 8: Front Panel

4.2 Display

Turn the power switch on. Be patient, the start up sequence will take about the same time as it takes a computer to boot up, approximately 2 minutes. At first the display backlight will blink and all output LEDs will light. Around 30 seconds later, the display backlight will come on, and the LEDs will shut off. Then the display will come up, and show you the % complete status of the start up process. After around 1 minute, the Summary Screen will appear. In 15 seconds, you will hear 3 beeps, and the controller is ready to go.

The Summary Screen will display the sensor inputs (Conductivity, pH, and/or ORP if applicable) and the most significant active alarm. Any additional alarms may be viewed by pressing the Down Arrow key.



Figure 9: Display

4.3 Keypad

The keypad consists of 4 directional arrow keys (up, down, left and right), 4 menu/function keys (previous, next, exit and enter), and 4 quick access keys (home, calibrate, relays, and help).

The arrow keys are used to change settings (up and down) and move the cursor to a different location within that menu in order to change that setting (left and right).

The function keys are used to navigate through the different menu selections. The Next and Prev keys move you from menu to menu. The Enter key is used to enter a submenu, and to accept a new setting. The Exit key is used to back up one menu level. No matter where you are in the menus, pressing Exit enough times will bring you to the Summary Screen (or press Home, see below).

To change a numeric value, move the cursor to the digit you want to change by pressing the left or right arrow keys, then use the up or down arrow keys to change the value. Press the Enter key after all digits have been changed to enter the new value into memory. Similarly, to change an alphanumeric value, use the up or down arrow keys to change that character, and the left and right arrow keys to move to the next character. Press the Enter key after all characters have been changed.

The quick access keys bring you directly to frequently used or critical functions. The Home key will bring you directly back to the Summary Screen. The CAL key will bring you directly to the sensor calibration menus. The Relays key will bring you directly to menus that allow you to force the relays off or on. The Help key is under construction. Refer to Section 5.0 for details on use of the keypad for sensor calibration, relay control, setting communications parameters, etc.

4.4 Access Codes

The WebMasterONE series controller is shipped with the access codes at default values. In order to prevent against unauthorized tampering, you will need to change the access codes to your own values. See section 6.42 for details.

There are three levels of protection. If the *Master* password is used in the WebMasterONE Authentication page, then any set point can be changed. The default Master password is 2001.

If the *Calibration* password is used in the Authentication page, then sensor calibrations will be allowed, but other changes will not. The default Calibration password is 2002.

If the *Read Only* password is used the user will be able to look at any page, but will not be allowed to make any changes. The default Read Only is 2003.

The default user name is "webmaster." This can and should be changed in the Access Code page. See section 6.42 for details.

4.5 Initial Startup

Turn the power switch on. Be patient, the start up sequence will take about the same time as it takes a computer to boot up, approximately 2 minutes. At first the display backlight will blink and all output LEDs will light. Around 30 seconds later, the display backlight will come on, and the LEDs will shut off. Then the display will come up, and show you the % complete status of the start up process. After around 1 minute, the Summary Screen will appear. In 15 seconds, you will hear 3 beeps, and the controller is ready to go.

The WebMasterONE Series controllers have a wide range of capabilities, so the steps required preparing the site for installation would be different depending upon the capability you will be using.

Currently the WebMasterONE has only limited functionality for the local display and keypad. ALL of the programming must be accomplished using a computer.

You will be able to calibrate all sensor inputs, change access codes, and enter the information necessary to communicate with the WebMasterONE via an Ethernet connection or via the modem over the Internet (if a modem card is installed in the controller). If neither of these communications options are installed, you must use an USB connection to a PC for programming. You may set most set points with the keypad, but you may not change operating modes (for example, you may change the pump on time for a time-based add, but not the time of day; nor can you change from a 1 week cycle to a 2 week cycle).

If you have a stand-alone controller with no communications, but you do have a computer to connect to the USB port on the front panel of the controller for programming, go to the section below called “Connection via the USB Port”.

If you have a controller that is equipped with a modem, then you can take full advantage of the WebMasterONE. The controller is like a web server. Once you set up an Internet Service Provider (ISP) account for the controller, you can “surf” to the controller from any web connected computer to access data or reconfigure the controller. The controller can also contact you, by email or pager, in case of trouble. In this case, a dedicated analog phone line that does not go through a company switchboard for the controller must be provided. For details, go to the section below called “Remote Modem Access: Shoulder Tap.” The ISP information must be entered into the controller via the USB port, or via the local keypad before attempting a Shoulder Tap connection.

If you have not yet set up an ISP account and wish to program the WebMasterONE from a remote location, or if you just prefer the “old fashioned method” of direct modem-to-modem communication, go to the section below called “Direct Modem Access: Direct Tap.”

If you have the Ethernet connected, then the controller can become another PC on the network. You can use your web browser software, enter the controller’s address (assigned by your network administrator) and access data or reconfigure the controller. You will need to have a network node nearby to connect your WebMasterONE. See the section below called “Ethernet Connection to LAN”.

You may also use the Ethernet card in your laptop to communicate with the Ethernet card in the WebMasterONE. This requires a special null (crossover) cable and the Ethernet parameters must be programmed into the WebMasterONE using either USB or the local keypad. Refer to the section below called “Direct Ethernet (for an WebMasterONE not connected to the LAN).”

Uploading Configuration Files

You can save all of the set points from a previously programmed controller, and then upload the same set points into another controller. If you have already downloaded a configuration file from a previously programmed controller, you can upload that file to this controller in order to make all the set points the same. If you want to save the set points of this controller for use in future controllers, or want to program this controller using a stored configuration file, refer to section 6.40 for specific instructions.

See the appropriate section above, depending upon how you plan on uploading the configuration file; via a laptop connected to the front panel, via modem, via Ethernet connection, or via local PC connected to the USB port.

4.6 Communicating with the WebMasterONE

4.6.1 Connection via the USB Port



A USB connection to the WebMasterONE can be made via a temporary cable between a laptop and the front panel of the controller.

Equipment Required

- An USB cable with the appropriate connectors to connect your computer to the WebMasterONE.
- An Internet-ready computer with the following capabilities: 100 MHz minimum processor speed, 40 MB minimum RAM, Windows 2000 or XP operating system, and Windows Internet Explorer version 5.0 or higher web browser software.

Features Required in the WebMasterONE

- Any WebMasterONE controller is capable of an USB connection.

Utilities you need to set up on your computer

- The first time you connect the controller to your computer, it will recognize that new hardware is present. You will be prompted to install the driver using the supplied CD. After this point, your computer will recognize the WebMasterONE automatically.

Parameters that need to programmed into the WebMasterONE

- The WebMasterONE is capable of this type of communication without any programming by the user prior to attempting the communication.

Steps Required to Establish a Connection

- Connect the supplied USB cable between the WebMasterONE and your computer.
- Install the driver on your PC by inserting the disc supplied and following the instructions. This needs to done only once for each PC that will be used to communicate with a WebMasterONE controller.
- Go to Control Panel, Network Connections, and locate the new Local Area Connection 2 that has been created. Click on the Properties button. Highlight Internet Protocol (TCP/IP) then click Properties. Click Use the following IP address and enter 199.199.199.1. Click OK to exit. This needs to done only once for each PC that will be used to communicate with a WebMasterONE controller.
- Open Internet Explorer and type in the address 199.199.199.2. The sign-on screen for the WebMasterONE will come up.
- The sign-on screen of the WebMasterONE will come up. Type the User Name and Password (Access Code) in the text boxes and click the Submit button. The default user name is "webmaster" and the default passwords are "2001" for full access, "2002" for calibration only, and "2003" for read only. These defaults can and should be changed in the Access Code page.

4.6.2 Remote Modem Access: Shoulder Tap

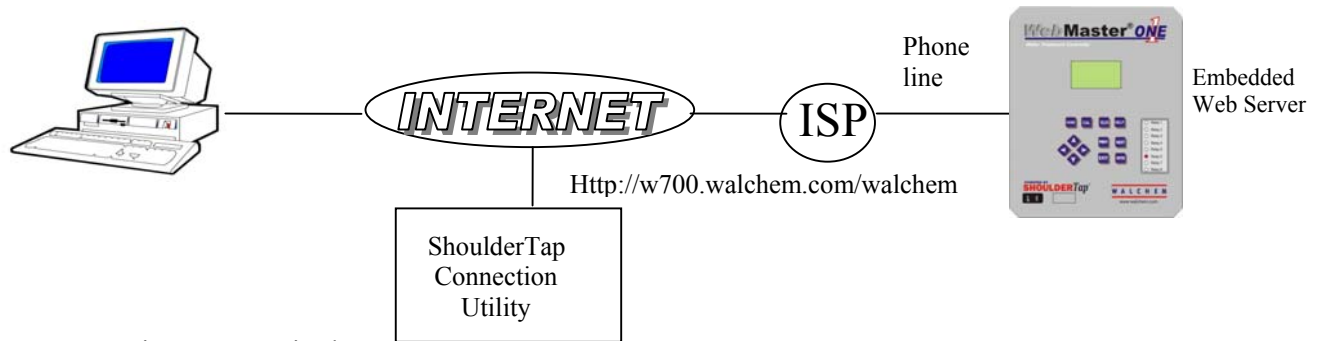

Equipment Required

- An Internet-ready computer with the following capabilities: 100 MHz minimum processor speed, 40 MB minimum RAM, Windows operating system, and Windows Internet Explorer version 5.0 or higher web browser software.
- An active analog phone line, direct to the controller (without a PBX system in between) must be connected to the modem of the WebMasterONE.
- A dialup account must be established for the WebMasterONE with an Internet Service Provider (ISP). The connection will only be as reliable as the ISP. You should avoid small mom-and-pop ISPs unless you know that they can provide reliable connection to the Internet. ISPs that require the installation of a CD (AOL, AT&T Worldnet, etc.) cannot be used. Contact the factory for recommendations.

Features Required in the WebMasterONE

- The WebMasterONE must have the modem option installed in order to communicate via Shoulder Tap.

Utilities you need to set up on your computer

- There are no special drivers, adapters or other software components required on the PC.

Parameters that need to be programmed into the WebMasterONE

- Prior to attempting a Shoulder Tap connection, the following information needs to be entered into the Communications page of the WebMasterONE, either via an USB connection, direct modem connection (Direct Tap) or via the local keypad. Some of this information needs to be provided to you by the Internet Service Provider (ISP) that the WebMasterONE will use to access the Internet.
- The controller's phone number.
- The local access phone number for the ISP. More than one access number may be entered.
- The ISP Username that the controller will use to connect to the ISP.
- The ISP Password that the controller will use to connect to the ISP.

Steps Required to Establish a Connection

- Connect your PC to the Internet.
- Enter the address <http://w700.walchem.com/walchem>.
- Click the link "Log onto WebMasterONE", which will bring you to the WebMasterONE Connection Utility Authentication Page.
- Enter the Connection Utility Username (WebMaster) and Password (2001) and click the Submit button.
- Enter the phone number of the controller and click the Connect button. After a few minutes, the sign-on screen for the WebMasterONE will come up.
- The sign-on screen of the WebMasterONE will come up. Type the User Name and Password (Access Code) in the text boxes and click the Submit button. The default user name is "webmaster" and the default passwords are "2001" for full access, "2002" for calibration only, and "2003" for read only. These defaults can and should be changed in the Access Code page.

4.6.3 Ethernet Connection to LAN

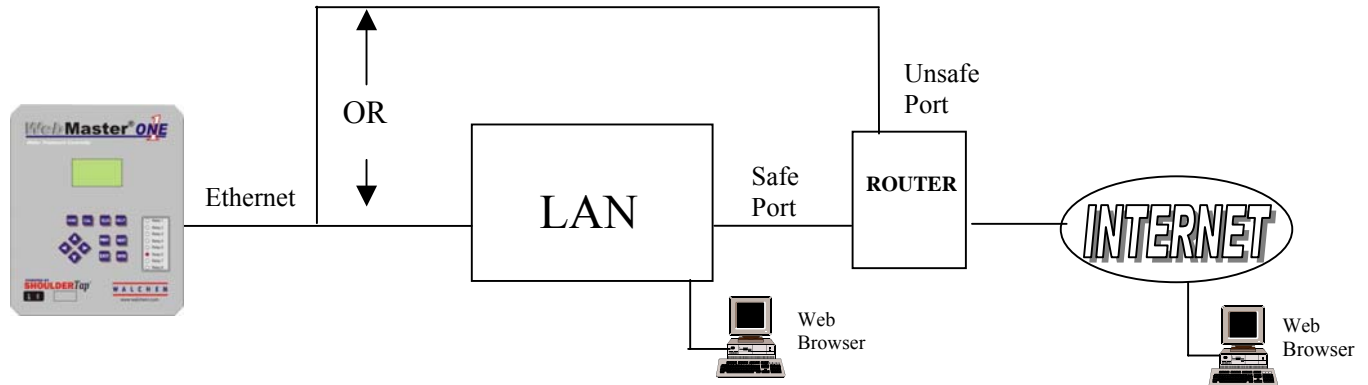

Equipment Required

- An Internet-ready computer with the following capabilities: 100 MHz minimum processor speed, 40 MB minimum RAM, Windows operating system, and Windows Internet Explorer version 5.0 or higher web browser software.
- A connection between the PC and the local area network (LAN).
- An Ethernet connection between the WebMasterONE and the LAN.

Features Required in the WebMasterONE

- The WebMasterONE must have the Ethernet option installed in order to communicate via an Ethernet connection.

Utilities you need to set up on your computer

- There are no special drivers, adapters or other software components required on the PC.

Parameters that need to be programmed into the WebMasterONE

- Prior to attempting an Ethernet connection, the following information needs to be entered into the Communication page of the WebMasterONE, either via an USB connection or via the local keypad. This information must be provided by the IT Administrator of the LAN.
- The Ethernet IP address of the WebMasterONE. If the controller will only be accessed by computers on the LAN then this may be a fake IP address. If the controller needs to be accessible by computers not on the LAN then this must be a real IP address.
- The Subnet Mask.
- The Gateway IP address.

Steps Required to Establish a Connection

- Open Internet Explorer.
- Type in the Ethernet IP address that has been assigned by the IT Administrator.
- The sign-on screen of the WebMasterONE will come up. Type the User Name and Password (Access Code) in the text boxes and click the Submit button. The default user name is "webmaster" and the default passwords are "2001" for full access, "2002" for calibration only, and "2003" for read only. These defaults can and should be changed in the Access Code page.

4.6.4 Direct Modem Access: Direct Tap

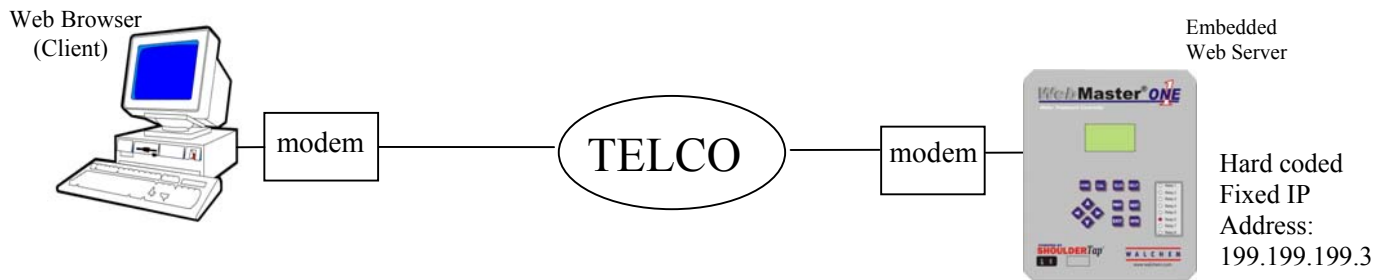

Equipment Required

- An Internet-ready computer with the following capabilities: 100 MHz minimum processor speed, 40 MB minimum RAM, Windows operating system, modem and Windows Internet Explorer version 5.0 or higher web browser software.
- An active analog phone line, direct to the controller (without a PBX system in between) must be connected to the modem of the WebMasterONE.

Features Required in the WebMasterONE

- The WebMasterONE must have the modem option installed in order to communicate via Direct Tap.

Utilities you need to set up on your computer

- A Windows dialup networking adapter must be created. Refer to the Quick Start Guide instructions for this procedure.

Parameters that need to be programmed into the WebMasterONE

- The WebMasterONE is capable of this type of communication without any programming by the user prior to attempting the communication.

Steps Required to Establish a Connection

- Create the dialup networking adapter on your PC. This needs to be done only once for each PC that will be used to communicate with a WebMasterONE controller.
- Use the dialup networking adapter to connect the PC to the WebMasterONE.
- Open Internet Explorer.
- Type in the address 199.199.199.3. The sign-on screen for the WebMasterONE will come up.
- The sign-on screen of the WebMasterONE will come up. Type the User Name and Password (Access Code) in the text boxes and click the Submit button. The default user name is "webmaster" and the default passwords are "2001" for full access, "2002" for calibration only, and "2003" for read only. These defaults can and should be changed in the Access Code page.

4.6.5 Direct Ethernet (for a WebMasterONE not connected to a LAN)

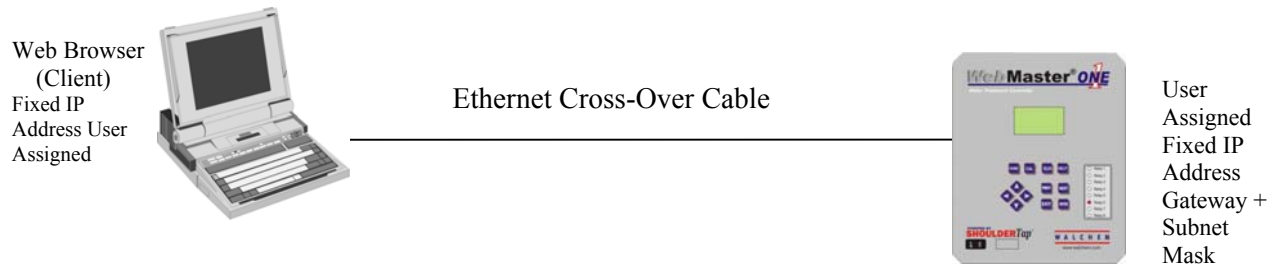

Equipment Required

- An Internet-ready computer with the following capabilities: 100 MHz minimum processor speed, 40 MB minimum RAM, Ethernet card, Windows operating system, and Windows Internet Explorer version 5.0 or higher web browser software.
- A null (cross-over) Ethernet cable connection between the PC and WebMasterONE.

Features Required in the WebMasterONE

- The WebMasterONE must have the Ethernet option installed in order to communicate via an Ethernet connection.

Utilities you need to set up on your computer

- There are no special drivers, adapters or other software components required on the PC. However if your laptop is used on a LAN it is likely that you will have to change your network TCP/IP properties to use a specific IP address for your PC instead of obtain an IP address automatically.
- You will have to specify the IP address and the Subnet Mask. Go to Control Panel, Network Connections, Local Area Connection. Click the Properties button. Highlight Internet Protocol (TCP/IP) then click Properties. Click Use the following IP address and enter 10.0.100.30. Set the Subnet Mask to 255.255.254.0 Click OK to exit.

Parameters that need to be programmed into the WebMasterONE

- The default settings will work with the LAN settings shown above. The default IP address for the controller is 10.0.100.29. The default subnet mask is 255.255.254.0.

Steps Required to Establish a Connection

- Open Internet Explorer.
- Type in the Ethernet IP address that has been assigned to the WebMasterONE (10.0.100.29).
- The sign-on screen of the WebMasterONE will come up. Type the User Name and Password (Access Code) in the text boxes and click the Submit button. The default user name is "webmaster" and the default passwords are "2001" for full access, "2002" for calibration only, and "2003" for read only. These defaults can and should be changed in the Access Code page.

4.6.6 Networking WebMasterONE Controllers via Ethernet

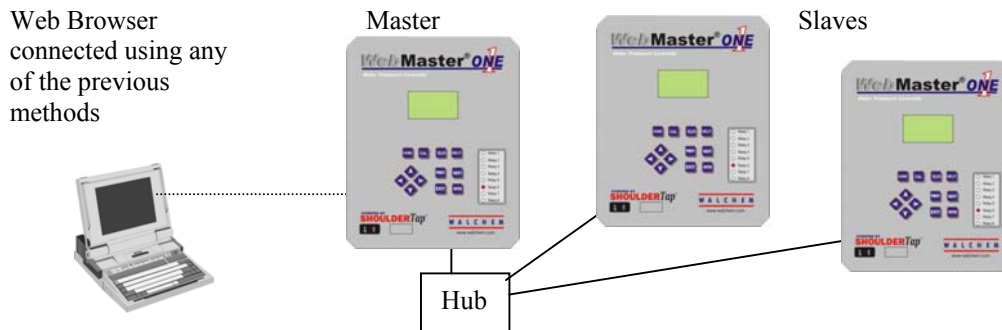

Equipment Required

- An Internet-ready computer with the following capabilities: 100 MHz minimum processor speed, 40 MB minimum RAM, Ethernet card, Windows operating system, and Windows Internet Explorer version 5.0 or higher web browser software.
- An Ethernet cable connection between each WebMasterONE using a hub or connection to LAN.

Features Required in the WebMasterONE

- Each WebMasterONE must have the Ethernet option installed. One must have the Master Capability software installed.

Utilities you need to set up on your computer

- There are no special drivers, adapters or other software components required on the PC to support networking. Refer to the previous sections for connecting to the master controller via USB, Ethernet, or modem.

Parameters that need to be programmed into the WebMasterONE

- Prior to attempting an Ethernet connection, the following information needs to be entered into the Communication page of each WebMasterONE on the network, either via an USB connection or via the local keypad.
- The Ethernet IP address of the WebMasterONE.
- The Subnet Mask.
- The Gateway IP address.
- The master must be selected as the master, and the slaves selected as slaves.

Steps Required to Establish a Connection

- Connect to the master controller using one of the methods described in sections 4.6.1 through 4.6.5.
- The sign-on screen of the WebMasterONE will come up. Type the User Name and Password (Access Code) in the text boxes and click the Submit button. The default user name is "webmaster" and the default passwords are "2001" for full access, "2002" for calibration only, and "2003" for read only. These defaults can and should be changed in the Access Code page.
- Once connected to the master, you may connect to the slaves by clicking on the link under the heading of "Sub-Network".
- You must log onto each slave using its user name and password.

4.7 Startup

Once the controller has been set up for your application, start up is a simple process. Check your supply of chemicals, turn on the controller power, calibrate all sensors as necessary, supply the sensors with a flow of sample water, and it will start controlling.

4.8 Shut Down

To shut down the controller, simply turn off the power. All set points will be retained in memory.

It is important that the optional pH and ORP electrodes remain wet. If it is possible for these electrodes to dry out, remove them from the flow assembly and place them in a cup or back in their original soaker bottles containing either pH 4 buffer solution or cooling tower water. Take care to avoid freezing temperatures when storing the electrodes to avoid breakage of the glass.

5.0 OPERATION – Using Local Display and Keypad



On power-up, the WebMasterONE display will show the process values from the sensors, and the most important alarm message. If there is more than one alarm, then pressing the Down Arrow key will display the additional alarm messages.

Pressing the Enter key will display the Main Menu. The menu selections are:

- Input Summary
- Indices
- Output Summary
- Alarms
- Calibration
- Relay Control (HOA)
- Set Points
- Communication
- Access Codes
- Software Upgrade
- Copy to USB Disk
- Feature Activations

Use the Next key to move the cursor down the list, or the Prev key to move the cursor up the list. Once the cursor is on the desired menu, press the Enter key to enter that menu.

5.1 Input Summary

The Input Summary menu displays the readings from all of the sensors, as well as any optional digital inputs, and analog inputs. Use the Next key to scroll down the list, or the Prev key to scroll up the list. There are no programmable parameters in this menu. No access code is required to enter this menu.

Press the Exit key to return to the Main Menu.

5.2 Indices

The Indices menu displays the calculated values of the Ryznar's Stability Index (RSI), Langliers Saturation Index (LSI), Use the Next key to scroll down the list, or Prev key to scroll up the list.

Below the displayed values are menus to change the wet test data used to calculate the various Indices: Calcium Hardness, and Total Alkalinity. Use the Next key to scroll down the list. When the cursor is next to the value that needs to be changed, use the Left and Right Arrow keys to move the cursor to the appropriate digit, then use the Up and Down Arrow keys to change the value of the digit.

Keep in mind that the cursor can move to blank spaces to the left of the numbers and change the blank to a number. Decimal points and minus signs may also be entered.

5.3 Output Summary

The Output Summary menu displays the state of the relays and the mA output of the optional 4-20 mA output cards. Use the Next key to scroll down the list, or the Prev key to scroll up the list. There are no programmable parameters in this menu. No access code is required to enter this menu.

Press the Exit key to return to the Main Menu.

5.4 Alarms

The Alarms menu displays all alarm messages. Use the Next key to scroll down the list, or the Prev key to scroll up the list. There are no programmable parameters in this menu. No access code is required to enter this menu.

Press the Exit key to return to the Main Menu.

5.5 Calibration

The Calibration menu is used to calibrate the sensor inputs, as well as any optional 4-20 mA inputs. The list of options displayed will depend upon what options are installed in your WebMasterONE. Not all of the menus described below will necessarily appear on your display. An access code will be required to enter this menu. Use the Arrow keys to enter the access code, then press the Enter key to continue.

The possible inputs to calibrate include the following. Which parameters are available depends on which sensor type has been selected as being used:

- Sensor 1 – 4 (Sensor Cal and Temperature if applicable)
- 4-20 mA Input #1 through #8 (only if the optional 4-20 mA input card is installed)
- Each input will be listed using its Custom Name and Input Number

The possible calibration choices will be displayed. Use the Next key to move the cursor down the list, or the Prev key to move the cursor up the list. Once the cursor is on the desired menu, press the Enter key to start the calibration procedure.

Conductivity Calibration – Standard Contacting Electrode

“1 pt Process Cal – Calibrate” will be displayed. Press the Enter key to start the calibration. The reading from the system conductivity sensor will be displayed. Measure the conductivity of the system water using a hand held conductivity meter, and use the Arrow keys to enter the actual value. Press the Enter key to highlight ‘CONTINUE’, then press Enter again to put the new value into memory.

If the calibration correction factor is within +/- 50% of the uncalibrated conductivity, the display will say “Cal Successful”. Press the Enter key to resume control of the conductivity.

If the calibration factor is outside of +/- 50% of the uncalibrated conductivity, the display will say “New value out of limits, Cal Fail”. The most likely cause of this is a dirty sensor. Refer to Section 6 for cleaning instructions. If cleaning fails to cure the problem, refer to Section 7 for troubleshooting help.

Conductivity Calibration – Electrodeless Sensor

“1 pt Process Cal” and “Air Cal (Zero) will be displayed.

Use the Next key to move the cursor to the word “Calibrate” under the desired calibration routine. Press the Enter key to start the calibration procedure.

Air Cal (Zero)

The Air Calibration is necessary on initial start up, or when installing a new sensor, in order to set the sensor to read zero conductivity in air. This step must be done prior to the process calibration.

Place the Sensor in Air. Remove the sensor from the water and make sure that it is dry, especially in the holes. Wait for **several minutes** while the conductivity reading stabilizes. Press the Enter key to continue. If the value is within the range of calibration, it will display “Cal Successful”. Press the Enter key after replacing the sensor in the water.

If not, it will display “New value out of limits, Cal Fail”. Refer to Section 7 for troubleshooting.

1 pt Process Cal

The reading from the system conductivity sensor will be displayed. Measure the conductivity of the system water using a hand held conductivity meter, and use the Arrow keys to enter the actual value. Press the Enter key to highlight ‘CONTINUE’, then press Enter again to put the new value into memory.

If the calibration correction factor is within +/- 50% of the uncalibrated conductivity, the display will say “Cal Successful”. Press the Enter key to resume control of the conductivity.

If the calibration factor is outside of +/- 50% of the uncalibrated conductivity, the display will say “New value out of limits, Cal Fail”. The most likely cause of this is a dirty sensor. Refer to Section 6 for cleaning instructions. If cleaning fails to cure the problem, refer to Section 7 for troubleshooting help.

Temperature Calibration

The current temperature reading will be displayed. Measure the actual temperature of the system water and use the Arrow keys to enter this value. Press the Enter key to highlight 'CONTINUE', then press Enter again to put the new value into memory.

If the calibration factor is within +/- 15 degrees C (27 degrees F) the display will be "Cal Successful", otherwise it will be "Cal Fail".

pH Calibration

There are three calibration options that will be displayed. Use the Next key to move the cursor to the word "Calibrate" beneath the option that you want to use, then press the Enter key to start the calibration.

Most commonly used is the "2 pt Buffer Cal" where two pH standard solutions are used to calibrate the electrode. This is the most accurate, since the slope of the electrode (mV output per pH unit) is measured directly.

The "1pt Buffer Cal" is not as accurate, since it assumes that the slope of the electrode is 59 mV/pH unit, which will only be true with a new electrode. This can be OK if the pH never varies far from the value of the standard solution used in the calibration.

The third is a "1 pt Process Cal", where the pH electrode is left in the process solution, and the pH value is entered to match that of a hand held pH meter, or litmus paper. It also assumes a perfect slope.

2 pt Buffer Cal

Step 1 will explain that control is suspended during the calibration procedure. Press the Enter key when the cursor is on "Continue" to start the calibration. To cancel the calibration, press the Next key to move the cursor to "Cancel", then press the Enter key.

Step 2 will ask you to enter the temperature of the buffer solutions. Use the Arrow keys to change the value of the temperature, then press the Enter key to highlight 'CONTINUE', then press Enter again to put the value into memory.

Step 3 will prompt you to rinse the electrode, and place it into the first buffer solution. Press the Enter key to continue.

Step 4 will ask you to enter the value of the first buffer solution. Use the Arrow keys to change the value, then press the Enter key to highlight 'CONTINUE', then press Enter again to put the value into memory.

Step 5 will display the mV output of the electrode in the first buffer. When this reading is stable, press the Enter key to continue.

Step 6 will prompt you to rinse the electrode and place it in the second buffer. Press the Enter key to continue.

Step 7 will ask you to enter the value of the second buffer. Use the Arrow keys to change the value, then press the Enter key to highlight 'CONTINUE', then press Enter again to put the value into memory.

Step 8 will display the mV output of the pH electrode in the second buffer. When the reading is stable, press the Enter key to continue.

At the end of the calibration, the display will tell you if the calibration was successful or if the calibration failed. If successful, press the Enter key after the electrode has been replaced into the sample stream to resume control. If failed, refer to Section 7 for troubleshooting help. The calculated slope being more than 80% different from theoretical causes a calibration failure, or by the pH 7 mV offset being more than 60 mV.

1 pt Buffer Cal

Step 1 will explain that control is suspended during the calibration procedure. Press the Enter key when the cursor is on “Continue” to start the calibration. To cancel the calibration, press the Next key to move the cursor to “Cancel”, then press the Enter key.

Step 2 will ask you to enter the temperature of the buffer solution. Use the Arrow keys to change the value of the temperature, then press the Enter key to continue.

Step 3 will prompt you to rinse the electrode, and place it into the buffer solution. Press the Enter key to continue.

Step 4 will ask you to enter the value of the buffer solution. Use the Arrow keys to change the value, then press the Enter key to continue.

Step 5 will display the mV output of the electrode in the buffer. When this reading is stable, press the Enter key to continue.

At the end of the calibration, the display will tell you if the calibration was successful or if the calibration failed. If successful, press the Enter key after the electrode has been replaced into the sample stream to resume control. If failed, refer to Section 7 for troubleshooting help. The calculated slope being more than 80% different from theoretical causes a calibration failure, or by the pH 7 mV offset being more than 60 mV.

1 pt Process Cal

Step 1 will display the current pH reading of the system water. Below that, use the Arrow keys to fill in the new value, then press the Enter key to continue.

At the end of the calibration, the display will tell you if the calibration was successful or if the calibration failed. If successful, press the Enter key after the electrode has been replaced into the sample stream to resume control. If failed, refer to Section 7 for troubleshooting help. The calculated slope being more than 80% different from theoretical causes a calibration failure, or by the pH 7 mV offset being more than 60 mV.

ORP Calibration

2 pt Buffer Cal

Step 1 will explain that control is suspended during the calibration procedure. Press the Enter key when the cursor is on “Continue” to start the calibration. To cancel the calibration, press the Next key to move the cursor to “Cancel”, then press the Enter key.

Step 2 will prompt you to rinse the electrode, and place it into the first buffer solution. Press the Enter key to continue.

Step 3 will ask you to enter the value of the first buffer solution. Use the Arrow keys to change the value, then press the Enter key to highlight ‘CONTINUE’, then press Enter again to put the value into memory.

Step 4 will display the mV output of the electrode in the first buffer. When this reading is stable, press the Enter key to continue.

Step 5 will prompt you to rinse the electrode and place it in the second buffer. Press the Enter key to continue.

Step 6 will ask you to enter the value of the second buffer. Use the Arrow keys to change the value, then press the Enter key to highlight 'CONTINUE', then press Enter again to put the value into memory.

Step 7 will display the mV output of the pH electrode in the second buffer. When the reading is stable, press the Enter key to continue.

At the end of the calibration, the display will tell you if the calibration was successful or if the calibration failed. If successful, press the Enter key after the electrode has been replaced into the sample stream to resume control. If failed, refer to Section 7 for troubleshooting help. A calibration will fail if the offset calculated is more than 200 mV, or if the slope calculated is outside of 0.5-1.5.

1 pt Buffer Cal

Step 1 will explain that control is suspended during the calibration procedure. Press the Enter key when the cursor is on "Continue" to start the calibration. To cancel the calibration, press the Next key to move the cursor to "Cancel", then press the Enter key.

Step 2 will prompt you to rinse the electrode, and place it into the buffer solution. Press the Enter key to continue.

Step 3 will ask you to enter the value of the buffer solution. Use the Arrow keys to change the value, then press the Enter key to highlight 'CONTINUE', then press Enter again to put the value into memory.

Step 4 will display the mV output of the electrode in the buffer. When this reading is stable, press the Enter key to continue.

At the end of the calibration, the display will tell you if the calibration was successful or if the calibration failed. If successful, press the Enter key after the electrode has been replaced into the sample stream to resume control. If failed, refer to Section 7 for troubleshooting help. A calibration will fail if the offset calculated is more than 200 mV, or if the slope calculated is outside of 0.5-1.5.

1 pt Process Cal

Step 1 will display the current pH reading of the system water. Below that, use the Arrow keys to fill in the new value, then press the Enter key to highlight 'CONTINUE', then press Enter again to put the value into memory.

At the end of the calibration, the display will tell you if the calibration was successful or if the calibration failed. If successful, press the Enter key after the electrode has been replaced into the sample stream to resume control. If failed, refer to Section 7 for troubleshooting help. A failed calibration is caused by an offset from the uncalibrated reading of more than 200 mV.

4-20 mA Input 1-8 Calibration

Calibrate 4 mA

Following the instructions for your 4-20 mA transmitter, supply the WebMasterONE controller with a 4 mA signal from the transmitter. You should verify that the transmitter is accurate by measuring the output with an ammeter. You can read the present value of the mA signal as measured by the controller on the top line of the display. If the value is not exactly 4 mA, press the Enter key when the cursor is on “Calibrate 4 mA”. Once this is done, the controller will read the transmitter signal as exactly 4 mA.

The transmitter signal must be +/- 2 mA of the expected 4 mA value, or else the calibration will fail.

Calibrate 20 mA

Repeat this process, supplying the controller with a 20 mA signal from the transmitter, and press the Enter key when the cursor is on the “Calibrate 20 mA” to make the present value exactly 20 mA.

The transmitter signal must be +/- 2 mA of the expected 20 mA value, or else the calibration will fail.

5.6 Relay Control (HOA)

This menu will present you with a list of each relay. To the right of the name of the relay will be an indication of the current state of the relay (OFF, or ON). To the right of this, the display will show either the time that the relay has been on, counting up (if the relay is responding to set point, and the time for the relay to shut off is unknown) or the time that has left to be on, counting down (if the relay has been activated by a timer, and the controller knows when it will shut off). Below the name of the relay will be the words “HAND” “OFF” and “AUTO”, each with a radio button to the left of the word. Use the Next key to move the cursor to the line containing the radio buttons. Use the Left Arrow and Right Arrow keys to move the cursor to the desired relay mode. Press the Enter key to change the mode of the relay.

If the relay is in the AUTO mode, then it will respond to the set points or other programmed parameters. This is the normal mode for the relay to be in.

If the relay is in the OFF mode, then the relay will be open regardless of whether the programming of the controller dictates that the relay should be ON or OFF. IF THE POWER TO THE CONTROLLER IS CYCLED OFF AND BACK ON, THE RELAY WILL REVERT BACK TO AUTO MODE.

If the relay is in the HAND mode, then the relay will be closed regardless of whether the programming of the controller dictates that the relay should be ON or OFF. If a Hand Time Limit has been programmed in the controller, the relay will shut off after this time has elapsed, and the mode will revert back to AUTO.

5.7 Set Points

This menu is used to adjust any of the control set points for the relays that are simple entries of numbers. Any configuration of feed control modes (for example, bleed and feed versus feed based on makeup volume) or biocide cycles (for example, changing from daily to weekly adds), etc. may NOT be changed using the keypad. These types of changes require a computer to accomplish. Refer to Section 6 for detailed descriptions of each control mode and set point menu.

Pressing the Enter key with Set Points highlighted will bring you to this display:

SET POINTS

Relay 1 (R1) Set Points

Relay 2 (R2) Set Points

Relay 3 (R3) Set Points

Relay 4 (R4) Set Points

Relay 5 (R5) Set Points

Relay 6 (R6) Set Points

Relay 7 (R7) Set Points

Relay 8 (R8) Set Points

If the relay has been given a custom name, this name will precede the relay number.

Pressing Next moves the highlight down the list, while Prev moves the opposite direction. Press Enter to go into the highlighted menu. Press Exit to return to the Main Menu.

Relay 1- 8 Set Points

The set points available for each relay will vary depending upon the control mode selected. A computer connection is required to change the control mode. The units of measure of some of the set points will vary depending upon sensor input that may be assigned to the relay.

Set Point xxxxx (if control mode is any on/off set point, time proportional)

Use the arrow keys to change the process value at which you want the relay to activate. The set point value is limited to the range of the sensor input. Press Enter to accept the changes.

Dead Band xxxxx (if control mode is on/off set point)

Use the arrow keys to change the process value away from the set point at which the relay will deactivate. For example, if you are forcing the conductivity lower, your set point is 2000 $\mu\text{S}/\text{cm}$, and your dead band is 100 $\mu\text{S}/\text{cm}$, then the relay will activate at 2001 and deactivate at 1900 $\mu\text{S}/\text{cm}$. The purpose of the dead band is to prevent rapid cycling of the relay open and closed, which can shorten its life. The dead band should be set for the lowest value that still prevents the relay from chattering. Press Enter to accept the new value.

Sample Period (minutes) xxxx (if control mode is time proportional feed)

Use the arrow keys to adjust the number of minutes used for the time proportional control sample period. Any value between 1 and 1440 is acceptable. Press Enter to accept the new value.

Proportional Band xxxx (if control mode is time proportional feed)

Use the arrow keys to adjust the distance from the set point where the maximum output activation time will occur. This parameter will be in the units of measure of the sensor input used to control the relay. The acceptable range for this set point varies with the input. Press Enter to accept the new value.

Duration (if control mode is intermittent sampling)

Use the arrow keys to set the minutes and press Enter to accept the new value. Then press Next to move the cursor to the seconds and adjust with the arrow keys and press Enter to accept. Any value between 10 sec and 60 minutes is acceptable. The duration is the time that the valve will be open in order to get a fresh water sample to the electrode.

Hold Time (if control mode is intermittent sampling)

Use the arrow keys to set the minutes and press Enter to accept the new value. Then press Next to move the cursor to the seconds and adjust with the arrow keys and press Enter to accept. Any value between 10 sec and 10 minutes is acceptable. The hold time is the time that the valve will be closed following a sample, but prior to the conductivity measurement. The hold time should ensure that the sample is water and not steam.

Blowdown Time (if control mode is intermittent sampling)

Use the arrow keys to set the fixed blowdown time (in minutes) and press Enter to accept the new value. Any value between 1 and 1440 minutes is acceptable. If the conductivity exceeds the set point, the blowdown valve will activate for this time.

Interval Time (if control mode is intermittent sampling)

Use the arrow keys to set the time between samples (in minutes) and press Enter to accept the new value. Any value between 5 and 1440 minutes is acceptable.

Prop Band (if control mode is intermittent sampling, proportional blowdown)

Use the arrow keys to adjust the distance from the set point where the maximum output activation time will occur. This parameter will be in the units of measure of the sensor input used to control the relay. The acceptable range for this set point varies with the input. Press Enter to accept the new value.

Fixed Time to Feed (if control mode is feed with another relay, feed after another relay (fixed))

Use the arrow keys to set the minutes and press Enter to accept the new value. Then press Next to move the cursor to the seconds and adjust with the arrow keys and press Enter to accept. Any value between 1 sec and 1440 minutes is acceptable.

% of Relay to Feed (if control mode is feed after another relay (%))

Use the arrow keys to change the % of the time that the lead relay runs that this relay should run and press Enter to accept the change. Any value between 0 and 100% is acceptable.

Time Period (if control mode is feed as % of time)

Use the arrow keys to change the length of the time cycle to be used, then press Enter to accept the changes. Any value between 1 and 1440 minutes is acceptable.

% of Period to Feed (if control mode is feed as % of time)

Use the arrow keys to change the percentage of the time period that will be used to activate the relay, then press Enter to accept the changes. Any value between 0 and 100% is acceptable.

Spike Point (if control mode is any spike set point)

Use the arrow keys to change the higher set point then press Enter to accept the changes. The set point value is limited to the range of the sensor input.

Vol to Init xxxxx (if control mode is flow-based feed)

Use the arrow keys to change the volume of solution that needs to flow through the flow meter in order to trigger the chemical feed. Any value between 1 and 10,000 is acceptable. Press Enter to accept the new value.

Output On-Time (min) xxxx (sec) xx (if control mode is flow-based or counter-based feed)

Use the arrow keys to change the amount of time for the relay to be activated, once the previously specified volume of solution has passed through the flow meter, or counts have been detected by the digital input. First change the minutes using the arrow keys, then Press Enter. Any value between 1 and 1440 minutes is acceptable. Press Next to move to the seconds, and use the arrow keys to adjust the seconds. Press Enter to accept the new value.

Counts Before Trigger xxxxx (if control mode is counter-based feed)

Use the arrow keys to change the number of counts on the digital input that will trigger the relay to activate. Any value between 0 and 99,999 is acceptable. Press the Enter key to accept the new value.

Output On Time (if control mode is Dispersant)

Use the arrow keys to change the pump on time (in minutes) then press Enter to accept the changes. Any value between 1 and 1440 is acceptable.

Output On Time Setup (if control mode is biocide timer or spike set point based feed)

This menu is used to change the amount of time that the output will activate for each programmed event. Again, it is not possible to reschedule events using the keypad. Press Enter with Output On Time highlighted to access the screens that show each event:

RLY1-8 TIMER ADDS
Event A . . . T
Time Of Day xx:xx
Output On Time
(min)xxxx (sec)xx
NEXT for next event
PREV f. previous evnt

Use the arrow keys to change the relay on time in minutes. Any value between 1 and 1440 is acceptable. Press Enter to accept the new value. Press Next to move to the seconds, use the arrow keys to adjust the seconds, and Press Enter to accept the new value. Press Next to advance to the next programmed event, or Prev for the previous scheduled event. Prev will also move you from sec to min within an event.

Output Time Limit xxxx

Use the arrow keys to change the maximum amount of time that the relay can be continuously activated before the controller deactivates the relay and activates a Output Time Limit alarm. Press the Enter key to accept the new value. The Output Time Limit is intended to prevent runaway control on a faulty sensor input.

Note that the relay will not activate again until someone resets the timer!

It will take some experience to find out what the normal output on-time will be. If the relay cycles open and closed under worst case conditions in 30 minutes, you may want to set the Output Time Limit at 60 minutes.

Hand Time Limit xxxx

Use the arrow keys to change the maximum number of minutes that the Bleed output can be activated in the Hand mode. Any value between 0 and 1440 is acceptable. A value of 0 means the output can be left on indefinitely. Press Enter to accept the new value.

5.8 Communication

This menu is used to enter the information required to communicate with the WebMasterONE using the modem option via the Internet, or using the Ethernet option. Once this information is entered, a remote PC may be used to configuring all or the set points that are unavailable with the keypad.

For Internet communications, it is also possible to do a manual test of the WebMasterONE's ability to use its modem to dial a local Internet Service Provider (ISP) and connect to the Internet.

The display will show a list of the various parameters. Use the Next key to move the cursor to the line below the parameter. Use the Up and Down Arrow keys to change each character to the correct number, letter, or symbol. Use the Left and Right Arrow keys to move the cursor to the next character. Press Enter once all characters have been changed to the desired values.

Dial-up ISP Username (only if modem is installed)

When the controller needs to dial out and connect to the Internet Service Provider, it needs to identify itself with a user name, so that the ISP knows that it has an account. Enter the user name here.

Dial-up ISP Password (only if modem is installed)

Similarly, the controller needs to identify itself with a password in order to connect with the ISP. Enter the password here.

Dial-up ISP Local Phone (only if modem is installed)

Enter the phone number for the controllers Internet Service Provider. This will be the phone number that it attempts to dial when getting on the Internet.

Controller Phone # (only if modem is installed)

When you need to communicate with the controller, you go to the web site, link to the WebMasterONE access page, and a call is made from our server to the controller to wake it up. Enter the phone number for the controller, exactly as it needs to be dialed by our server in the USA. If the WebMasterONE is installed within the USA or Canada, this may include the 1 prefix. If the WebMasterONE is installed in another country, it must include the 011 prefix, country code, and phone number.

When the cursor is on the pull down menu for the country code, use the UP or DOWN arrow keys to scroll through the list of countries. The correct prefix (1 or 011) will be selected automatically. Then press Next to move the cursor to the phone number and use the Arrow keys to change the number. Press Enter to accept the changes.

Dial ISP (only if modem is installed)

This menu is used to manually dial the WebMasterONE's ISP. Press the Enter key when the cursor is on this to start the process.

A new screen will appear. The first line will show the **Dial up Status**. This menu is informational only, and tells you what is happening with the dialup connection. Possible status messages include:

<u>Message</u>	<u>Explanation</u>
Off Line	The controller is not connected.
Dialing xxx-xxxx	The controller is dialing out to the ISP.
No Dial Tone	The controller can not dial out due to phone line or modem problems.
No phone number	There is nothing entered in the ISP Phone No. field.
Connecting to ISP	The controller is successfully negotiating a connection with the ISP.
On Line	The controller is now on the Internet.
Checking for Upgrade	The controller is communicating with our server to see if a software upgrade is available.
Connection Timeout in xxxxx sec	The Internet connection process is complete. The number of seconds displayed depends upon the value entered in the Dialup Connection Lifetime text box described below.

The second line is the **Dial up Dynamic IP** Address. This is informational, and tells you the last IP assigned to the WebMasterONE by its ISP the last time it connected. When the manual ISP Dial up process is successful, this number should change.

The third line is the date and time of the last successful connection with the ISP.

The bottom line will display “Dial ISP”, “Log Off” and “Cancel”.

Pressing the Enter key while the cursor is on “**Dial ISP**” will make another attempt to dial the ISP. Pressing the Enter key while the cursor is on “**Log Off**” will disconnect the WebMasterONE from the ISP. It is VERY IMPORTANT that you log off, or the controller will keep the connection on the Internet until the connection times out. It is possible that this programmable maximum connection time could be set for infinity, which could be expensive!

Pressing the Enter key while the cursor is on “**Cancel**” will stop the WebMasterONE from attempting the Dial up process.

Ethernet IP Address

When a controller is attached to a network, your IT Administrator needs to assign it an Ethernet IP address. When you want to communicate with the controller from your PC on the network, you go to your Browser and type in the controller’s address.

Ethernet Subnet Mask

When a controller is attached to a network, your IT Administrator must also assign the IP Subnet Mask. Enter this number here.

Ethernet Gateway

When a controller is attached to a network, your IT Administrator must also assign the Gateway. Enter this number here.

5.9 Access Codes

There are three levels of access code protection. If the *Master* password is used in the WebMasterONE, then any set point can be changed. If the *Calibration Level* password is used, then sensor calibrations will be allowed, but other changes will not. If the *Read Only* password is used the user will be able to look at any menu, but will not be allowed to make any changes.

In order to change the access code for each level of access, use the Next key to move the cursor to the space next to Present, and use the Arrow keys to make the characters match the present access code (you have to know the present code to change it). Press the Enter key to move the cursor next to New, then use the Arrow keys to make the characters match your new access code and press Enter.

The default user name is "webmaster" and the default passwords are "2001" for full access, "2002" for calibration only, and "2003" for read only. These defaults can and should be changed to assure security.

5.10 Software Upgrade



CAUTION! There are live circuits inside the controller even when the power switch on the front panel is in the OFF position! The front panel must never be opened before power to the controller is REMOVED!

The software of the controller may be easily updated in the field, adding new features or fixing any bugs. This can be accomplished in a few quick steps:

- a. Save the new software upgrade to a 32 MB (or higher) USB flash memory stick. These are available from the factory, or may be found locally.
- b. Plug the memory stick into one of the USB Host connections on the core interface board (see Figure 3). The stick will only fit in one direction.
- c. Enter the Software Upgrade Menu. Press Next until the word START is highlighted, then press Enter.
- d. The Status section of the screen will indicate that the upgrade has started. Once it finishes (in a few minutes) the controller will reboot.
- e. Remove the memory stick. This may be used to upgrade as many controllers as you would like.

5.11 Copy to USB Disk



CAUTION! There are live circuits inside the controller even when the power switch on the front panel is in the OFF position! The front panel must never be opened before power to the controller is REMOVED!

The data log file may be manually downloaded to a USB disk. Press Enter to initiate the process:

1. Plug a USB memory stick into one of the USB host connections. The file size may be as large as 2 MB.
2. Press Enter when 'Copy User Log' is highlighted to start downloading.
3. When the Copy Status becomes 'File Copied', you may press Exit to return to the Main Menu and remove the USB disk.

5.12 Feature Activations

This menu is used to activate all of the various communications software features in the field. If you have purchased the controller with the communication feature, it will already be activated and no further action will be necessary. Press Enter to view a list of any activated features.

To activate a software feature in the field, purchase the activation key file from your distributor and save it on the root drive of a USB flash drive. Disconnect power to the controller, and insert the flash drive into the USB Host connector on the front panel (see figure 3). Close the front panel and restore power. Enter the Feature Activation menu. "New Activation" will be highlighted. Press Enter to open the New Activation menu. "Start" will be highlighted. Press Enter to start the activation process. The Status screen will display the progress and in a few seconds will show if the process was successful or not.

As many as three activation types are possible: Modbus TCP, Sub-Networking, and one of several communications options. If more than one feature needs to be activated, this process must be repeated for each one.

6.0 OPERATION – Using PC



These units control continuously as long as power is applied. This section describes how to set up the controller utilizing a PC. See Section 5.0 for instructions utilizing the controller keypad and display.

When you first access the controller, the System Summary page will be displayed in the main frame of the browser, and the Name of the controller and Alarm Status will be displayed in the top frame. Links to each main menu page are located along the left side of the screen.

The menus are organized by inputs and outputs. Each input has menus for calibration, selecting units of measure, etc. as required. Each output has menus for defining the set points, maximum on-time, method of control, etc.

Keep in mind when the controller is powered, it will be responding to default set points. As set points are changed, the controller will start using the new set points immediately. If it is undesirable for the controller to activate valves and pumps during the set up process, either disconnect them, or go to the "Hand-Off-Auto" menu for each output and force them "Off".

6.1 Menu Selection Links

Along the left side of your PC monitor will be links to the various menu pages. The exact configuration of your WebMasterONE Series controller will determine which menus are available to you. Some menus only appear if an optional circuit board is installed. Others only appear if a certain option is selected in the Start Up menu. Below is a list of all possible Menu selections, and when they will appear.

Menus that appear all the time:

Start up	Level	Data Logging
System Summary	Flow meter	Auto Reporting
“Custom Name” Sensor 1	Generic	Communications
“Custom Name” Relay 1	Interlock	Configuration File
“Custom Name” Relay 2	Level Switch	Notepad
“Custom Name” Relay 3	PosiFlow	Access Codes
“Custom Name” Relay 4	Generic Input	LSI/RSI
“Custom Name” Relay 5	Counter	Graphing/Trending
“Custom Name” Relay 6	4-20 mA Input	Advanced Comms
“Custom Name” Relay 7	Digital Inputs	
“Custom Name” Relay 8		

Menu that appears only if one or more sensor input boards are installed:

“Custom Name” Sensor 2
“Custom Name” Sensor 3
“Custom Name” Sensor 4

Menu that appears only if a software upgrade is available:

Software upgrade

Menu that appears only if one or more 4-20mA output boards are installed:

4-20mA Outputs

6.2 Start up Menu

Select the option that you want for each of the sections on the page. When you click on the “Submit” button at the bottom of the page, your changes will take effect. If you move to another page without clicking “Submit” first, your changes will be lost!

Controller Name

Type the name that you want to use to identify the controller, up to 32 characters, in the text box. For example, “XYZ Corp, North Tower”

Controller Time and Date

Update the date and time by clicking the arrow on the pull-down list and selecting the correct values.

Controller Date Format

Click on the radio button that corresponds to the desired date format. The choices are Month/Day/Year, Day/Month/Year or Year/Month/Day.

Sensors 1-4

Use the pull-downs to select which type of sensor is connected to that input. If the input option cards are not installed for Sensors 2-4, then the pull-down will not be available. The sensor options

are Not Used, Contacting Conductivity, Electrodeless Conductivity, pH, ORP and High Temp Conductivity.

Make sure that you correctly match the programmed sensor type with the actual sensor type connected to that input!

Digital Inputs

Use the pull-downs to select the function for each of the digital inputs. Digital Inputs A-C are standard, while Digital Inputs 1-6 are only available if the Digital Input option card has been installed. The functions available are explained below.

Make sure that you correctly match the programmed sensor type with the actual sensor type connected to that input!

Not Used should be selected if nothing is connected to that input.

Contacting Flow Meter should be selected if a low frequency (10 Hz maximum) contacting-head water meter is connected to that input. These are generally reed switch sensors that give one dry contact closure every gallon or more of volume through the meter. A sensor of this type must be connected to Digital Input A, B, C or 1-4.

Paddlewheel Flow Meter should be selected if a high frequency (10 – 300 Hz) Hall Effect style flow meter is connected to the input. The input is not compatible with flow sensors that generate their own sine wave. A sensor of this type must be connected to Digital Input A, B, C or 5-6.

Counter should be selected if the contact closure from the sensor will be used to log counts and/or to initiate a relay to activate for a given time after a given number of counts. A sensor of this type can be connected to any Digital Input.

Interlock should be selected if the contact closure will be used to deactivate relays that are normally being controlled by some other means. A sensor of this type can be connected to any Digital Input.

Level Switch should be selected if the device connected is a liquid level switch. This is normally used to send an alarm if the liquid level gets too high or low. A sensor of this type can be connected to any Digital Input.

PosiFlow should be selected if a PosiFlow metering pump feed verification device is connected to the input. These devices can count strokes of the pump's diaphragm, totalize the flow, and send an alarm if the WebMasterONE relay used to activate the pump is active, but the PosiFlow is not registering any flow. A sensor of this type can be connected to any Digital Input.

Generic Input should be selected if the contact closure will be used to log the current state of the contact (open or closed). A custom message can be assigned to each state. An alarm may be sent if the contact changes state, if desired. A sensor of this type can be connected to any Digital Input.

4-20 mA Inputs 1 - 8

This section will only appear if there is an analog input card installed in the controller.

Use the pull-downs to select the function of the analog input channel. The functions available are described below.

Make sure that you correctly match the programmed sensor type with the actual sensor type connected to that input!

Not Used should be selected if nothing will be connected to the input channel.

Level should be selected if a liquid level transmitter will be connected to the input channel. The input can be logged, or alarms sent if the level is outside programmed values.

Flow Meter should be selected if a flow transmitter is connected to the input channel. The controller can log the flow rate, total flow volume, and alarm if the flow rate or total is outside programmed values. Relays can also be controlled to activate for a given time after a given volume of solution has passed through the flow meter.

Generic should be selected if the transmitter connected to the input is anything else but the types described above. You will be able to span the input, give it a custom name and units of measure, set alarm points, and use it to control relays.

Relay (1 – 8) Control Mode

Use the pull-downs to select the control mode for each relay. The various choices are described below. **Once the control modes have been selected, click the Submit Changes button.** This will change the Relay Input Assignment section that comes next, making the possible choices for the input assignment match the control mode.

Not Used should be selected if the relay is not being used.

On/Off Set Point should be selected if the relay needs to respond to a sensor input or analog input signal. The relay will activate and deactivate if the input value goes outside of programmed limits. In the relay menu, you will specify the set point value, dead band value, control direction, etc.

Time Proportional should be selected if the relay will be activated for a larger percentage of a programmable time period as the process value gets further away from the set point value.

Cycles of Concentration should be selected to activate the relay based on a set point that is the ratio of two conductivity sensor input readings. This option is only available if at least two sensors are defined as conductivity sensors.

Intermittent (Fixed Blowdown Time) should be selected for boiler control where the conductivity is checked at a fixed time interval, and if found to be above the set point, the relay is activated for a fixed time.

Intermittent (Proportional Blowdown Time) should be selected for boiler control where the conductivity is checked at a fixed time interval, and if found to be above the set point, the relay is activated for a time that varies with the conductivity's deviation from the set point.

Flow based Feed should be selected if the relay will be triggered to activate for a programmable amount of time after a given volume of water has passed by the flow meter. In the relay menu, the volume to trigger feed, and the amount of time of the feed will be specified.

Feed With Another Relay should be selected if you want to activate this relay at the same time as another relay (for example, inhibitor feed and bleed).

Feed After Another Relay (%) should be selected if you want to activate this relay after another relay has finished its activation cycle (for example, inhibitor feed after bleed). This relay will activate for a percentage of the time that the other relay was active.

Feed After Another Relay (Fixed Time) should be selected if you want to activate this relay after another relay has finished its activation cycle (for example, inhibitor feed after bleed). This relay will activate for a programmable amount of time.

Feed as % Time should be selected to activate the relay for a given percentage of a user-specified time period.

Spike Set Point 1 Week Cycle should be selected to activate the relay based on one set point for a majority of the time, and then spiking the concentration for a programmable amount of time, as often as once per day, on a weekly schedule. This is typically an oxidizer addition based on an ORP electrode.

Spike Set Point 2 Week Cycle should be selected to activate the relay based on one set point for a majority of the time, and then spiking the concentration for a programmable amount of time, as often as once per day, on a bi-weekly schedule. This is typically an oxidizer addition based on an ORP electrode.

Spike Set Point 4 Week Cycle should be selected to activate the relay based on one set point for a majority of the time, and then spiking the concentration for a programmable amount of time, as often as once per day, on a monthly schedule. This is typically an oxidizer addition based on an ORP electrode.

Daily Biocide Timer should be selected if the relay will be activated up to 10 times per day, every day, at a programmed time of day, for a programmed amount of time. In the relay menu, you will specify the time of day for the relay to activate, as well as the amount of time it will be activated.

1 Week Biocide Timer should be selected if the relay will be activated on a schedule that is the same every week. In the relay menu, you will specify the day of the week and the time of day for the relay to activate, as well as the duration of the activation. The relay can activate only once per day.

2 Week Biocide Timer is identical to the weekly timer, except the schedule will repeat in a two-week cycle.

4 Week Biocide Timer is identical to the weekly timer, except the schedule will repeat every four weeks.

Dispersant should be selected to activate the relay for a fixed time either before or after a biocide addition.

Bleed Volume based on Makeup Volume should be selected if the relay will be triggered to activate by a volume of makeup water, and will be deactivated by a volume of bleed. Note that flow meters must be installed on both the bleed and the makeup lines to use this mode.

Alarm should be selected if the relay is to be activated based on an alarm condition. **This option is reserved for Relay 8 only!**

Click on the “Submit Changes” button to save the changes. This will change the Relay Input Assignment section that comes next, making the possible choices for the input assignment match the control mode.

Analog Output Control Mode (1 – 4)

This section will only appear if there are one or more 4-20 mA output cards installed.

Use the pull-downs to select the control mode for each analog output: Not Used or Retransmit.

Relay (1 – 8) Input Assignment

This section is where the input used to control the relay is assigned. The choices available in the pull-down will depend upon the control mode of the relay. If you have changed the control mode of any relay, click the Submit Changes button before selecting the input assignment.

If the relay control mode is Not Used:
The relay input assignment is Not Applicable.

If the relay control mode is On/Off Set Point, or Time Proportional:
The relay input assignment choices will be any of the sensor inputs, and any of the optional analog inputs. Any number of relays may be assigned to the same input.

If the relay control mode is Cycles of Concentration:
The relay input assignment choices will be any of the conductivity inputs. Any number of relays may be assigned to the same input.

If the relay control mode is Intermittent (Fixed Blowdown Time), Intermittent (Proportional Blowdown Time):
The relay input assignment choices will be any of the sensor or analog inputs. Any number of relays may be assigned to the same input.

If the relay control mode is Flow Based Feed or Bleed Vol on Makeup Vol:
The relay input assignment choices will be any digital or optional analog inputs that are defined as a flow meter input.

If the relay control mode is any of the Biocide Timer Based Feed options:
The relay input assignment is Not Applicable.

If the relay control mode is Feed with Another Relay, Feed After Another Relay (%) or Feed After Another Relay (Fixed Time):
The relay input assignment choices will be all the other relays.

If the relay control mode is Feed as % Time or Dispersant:
The relay input assignment is Not Applicable.

If the relay control mode is any of the Spike modes:
The relay input assignment choices will be all sensors and analog inputs.

If the relay control mode of Relay 8 is Alarm:
The relay input assignment is Not Applicable.

Analog Output Input Assignment (1 – 4)

This section will only appear if there are one or more 4-20 mA output cards installed.

Use the pull-downs to select the input signal that will be retransmitted as a 4-20 mA output signal. The possible choices include any sensor input, any sensor temperature compensation signal (not applicable for an ORP sensor), or any 4-20 mA input signal (only applicable if the analog input card is installed).

6.3 System Summary Menu

There are no programmable parameters in the System Summary Menu page. Several tables will be displayed, with information on sensor readings, analog input readings, digital input states, alarms, relay state, etc.

6.4 Sensor Menu - Conductivity Input

Select the option or type in the values that you want for each of the sections on the page. When you click on the “Submit” button at the bottom of the page, your changes will take effect. If you move to another page without clicking “Submit” first, your changes will be lost!

Certain menu sections will only be visible if you have selected certain options in the start up menu.

Type of Sensor

Click the pull-down to select the type of sensor that you have installed. The rest of this section assumes that you have selected contacting conductivity or electrodeless conductivity.



Warning! The power to the WebMasterONE must be cycled off and back on before the sensor type change is completely implemented! The detection of the actual type of sensor installed occurs at power up.

Custom Name

You can rename the input by typing a custom name in the text box provided. This name will appear as the link to the input page, on the System Summary report, as a choice for relay input assignments, on data logs, and in alarm messages.

Conductivity Range (only appears if the Type of Sensor is Electrodeless Conductivity)

Click on the radio button to select the conductivity range that matches your electrodeless conductivity sensor (and also the process to be measured!). The choices are 0 –1000 $\mu\text{S}/\text{cm}$, 0-10,000 $\mu\text{S}/\text{cm}$, 0-100 mS/cm , or 0-1,000 mS/cm .

You must have the correct sensor to match the conductivity range!

Conductivity Units

Click on the radio button to select the units of measure that you want to use. You will have to click the “Submit” button at the bottom of the page to see more menus that relate to ppm or % concentration if you change units of measure.

Current Reading/Perform Calibration

The *current reading* is a live reading of the calibrated conductivity of the sample.

To *Calibrate* the conductivity, click on the “Perform Calibration” button and a new window will open in your browser. You will have two options, a one-point process calibration or an air (zero) calibration.

Always set the *air calibration* first. This should only need to be done once for any given sensor. Click the Calibrate button. Make sure that the sensor is in the air and dry, then click the Continue button. The controller will either accept the calibration or will reject it if the voltage reading is too far from the expected for a zero reading. Click the Close button to return to the Conductivity Input page.

For the *one-point process calibration*, click its Calibrate button. It will display the current conductivity reading. Determine the actual conductivity of the solution by measuring it with a calibrated conductivity instrument, and type this value in the text box, then click the Continue button. The controller will either accept the calibration or will reject it if the conductivity entered is too far from the factory calibration reading. The limit is $\pm 50\%$ of the uncalibrated reading. Click the Close button to return to the Conductivity Input page.

Status

This section is for information only, and lets you know if any alarm conditions exist. Possible status messages are; Normal (everything is OK), Sensor Error (the sensor signal is not valid), High Alarm, Low Alarm or Calibration Time. For Sensors 2, 3 and 4 an error message for Circuit Board Failure is also possible. See section 8.1 for a complete description of error messages.

Date of Last Calibration

This section is for information only, and lets you know when the last calibration occurred.

Calibration Reminder

If you want to be reminded when the sensor needs calibration, for example every 30 days then type the desired number of days between calibration in the text box. A value of zero means you will never be reminded. The highest value allowed is 365 days.

Self Test

The Self Test is used to check the circuitry of the conductivity input. Click on the “Self Test” button, and the controller will display either Pass or Fail, and also readings of a simulated conductivity and temperature. If the controller passes self test, and you are having problems reading the correct conductivity, then the problem must be with the sensor, wiring or installation.

ppm Conversion Factor (only appears if ppm selected as the unit of measure)

Type the value that you want to use to convert $\mu\text{S}/\text{cm}$ to ppm into the text box. The range allowed is 0.5 to 1.0 ppm per $\mu\text{S}/\text{cm}$.

Uncalibrated Conductivity

This section is for information only, and shows the conductivity reading without any calibration. This is helpful in troubleshooting the conductivity sensor. During a one-point calibration, the new value must be within $\pm 50\%$ of this reading or else the calibration will be rejected.

High Alarm Limit

Type in the text box the conductivity (or ppm or % concentration) above which you want a high alarm to occur.

Low Alarm Limit

Type in the text box the conductivity (or ppm or % concentration) below which you want a low alarm to occur.

Click on the “Submit” button to save the changes.

Temperature

Note: The temperature sensor detection is checked when the WebMasterONE is powered up. Make sure that the sensor connections are made prior to turning on the power.

Current Temperature

Displays a live reading of the temperature of the system water. If no temperature sensor is detected at power-up, this will be “Manual Temperature” and allow the temperature to be typed into the text box.

Status

Possible status messages are; Normal (everything is OK), Sensor Error (the signal is not valid), High Alarm, or Low Alarm. See section 8.1 for a complete description of error messages.

Calibrate

Click on the “Calibrate” button and a new window will open that read “To Modify the Current Value”, and displays the current reading and a text box in which to type the actual value. Measure the temperature of the sample with a thermometer, and type the actual value into the text box. Click the Submit button. The new value will be displayed. Click the Close button to close the calibrate window.

This menu will not appear if no temperature sensor is detected at power-up.

Temperature Units

Click on the radio button to select units of measure of either Fahrenheit or Celsius.

Uncalibrated Temperature

Displays the temperature reading before correcting with calibration constants. This is helpful for troubleshooting.

This menu will not appear if no temperature sensor is detected at power-up.

High Alarm

In the text box, type the maximum temperature that you would reasonably expect to see for the sample. This is helpful to detect a faulty or poorly calibrated temperature sensor.

This menu will not appear if no temperature sensor is detected at power-up.

Low Alarm

In the text box, type the minimum temperature that you would reasonably expect to see for the sample. This is helpful to detect a faulty or poorly calibrated temperature sensor. This menu will not appear if no temperature sensor is detected at power-up.

Click on the “Submit” button to save the changes.

6.5 Sensor Menu - pH Input

Select the option or type in the values that you want for each of the sections on the page. When you click on the “Submit” button at the bottom of the page, your changes will take effect. If you move to another page without clicking “Submit” first, your changes will be lost!

Certain menu sections will only be visible if you have selected certain options in the start up menu.

Type of Sensor

Click the pull-down to select the type of sensor that you have installed. The rest of this section assumes that you have selected pH.

Custom Name

You can rename the input by typing a custom name in the text box provided. This name will appear as the link to the input page, on the System Summary report, as a choice for relay input assignments, on data logs, and in alarm messages.

Current Reading/Perform Calibration

The *current reading* is a live reading of the calibrated pH of the sample.

To *Calibrate* the pH electrode click on the “Perform Calibration” button and a new window will appear. Select a *2-point calibration*, a *1-point calibration* or a *1-point process calibration* by clicking the appropriate button.

2 Point Calibration

First you will see a warning that pH control will be suspended during the calibration. Click on “Continue” to start the calibration, or “Cancel” to abort the calibration.

If no temperature element is detected, then the controller will allow you to enter the buffer temperature manually. Otherwise it will display the electrode temperature.

You then be prompted to “Please Rinse the Electrode”. Do so, and then click “Continue”.

You will now be prompted to type in the value of the first buffer being used. Do so, and then click “Continue”.

You will now see the mV output from the electrode. When this value is stable, click “Continue”.

You then be prompted to “Please Rinse the Electrode”. Do so, and then click “Continue”.

You will now be prompted to type in the value of the second buffer being used. Do so, and then click “Continue”.

You will now see the mV output from the electrode. When this value is stable, click “Continue”.

The WebMasterONE will either pass or fail the calibration, and prompt you to return the electrode to the process. Click “Continue” when you are ready for pH control to resume.

If the calibration fails for any reason, refer to Section 8 for troubleshooting help.

1 Point Calibration

First you will see a warning that pH control will be suspended during the calibration. Click on “Continue” to start the calibration, or “Cancel” to abort the calibration.

If no temperature element is detected, then the controller will allow you to enter the buffer temperature manually. Otherwise it will display the electrode temperature.

You then be prompted to “Please Rinse the Electrode”. Do so, and then click “Continue”.

You will now be prompted to type in the value of the buffer being used. Do so, and then click “Continue”.

You will now see the mV output from the electrode. When this value is stable, click “Continue”.

The WebMasterONE will either pass or fail the calibration, and prompt you to return the electrode to the process. Click “Continue” when you are ready for pH control to resume.

If the calibration fails for any reason, refer to Section 8 for troubleshooting help.

1 Point Process Calibration

The new window will display the current value of the pH, using the last calibration. Measure the pH of a sample of the water using a handheld meter, and type the new pH value in the text box. Click the “Continue” button.

The WebMasterONE will either pass or fail the calibration. Control of the pH will continue throughout this process.

If the calibration fails for any reason, refer to Section 8 for troubleshooting help.

Status

Possible status messages are; Normal (everything is OK), Sensor Error (the signal is not valid), High Alarm, Low Alarm, Circuit Board Failure (for Sensors 2, 3 or 4) or Calibration Time. See section 8.1 for a complete description of error messages.

Date of Last Calibration

This section is for information only, and lets you know when the last calibration occurred.

Calibration Reminder

If you want to be reminded when the sensor needs calibration, for example every 30 days then type the desired number of days between calibration in the text box. A value of zero means you will never be reminded. The highest value allowed is 365 days.

Self Test

The Self Test is used to check the circuitry of the pH input. Click on the “Self Test” button, and the controller will display either Pass or Fail, and also readings of a simulated pH and temperature. If the controller passes self test, and you are having problems reading the correct pH or calibrating, then the problem must be with the electrode, wiring or installation.

Uncalibrated mV

Displays the mV signal from the pH electrode in the current sample. This is useful for troubleshooting.

Calculated Slope

This displays the slope (change in the mV output of the pH electrode per pH unit) of the pH electrode as of the last calibration. A perfect electrode will change by approximately 59 mV per pH unit. This is helpful for troubleshooting, and also to predict when the electrode may need to be replaced.

Calculated Offset

This displays the mV output of the pH electrode in pH 7 as of the last calibration. A perfect electrode will generate 0 mV at pH 7. The offset information is also helpful for troubleshooting.

% Difference from theoretical

This displays the % difference of the slope from the theoretical value as of the last calibration. The higher this percentage, the weaker the pH electrode. The calibration will fail if this percentage exceeds 80%. This number is the most useful to determine how much life is left in the electrode.

High Alarm Limit

Type in the text box the pH value above which a high pH alarm will be activated. Any value between -2 and 16 is acceptable.

Low Alarm Limit

Type in the text box the pH value below which a low pH alarm will be activated. Any value between -2 and 16 is acceptable.

Click on the “Submit” button to save the changes.

Temperature

Note: The temperature sensor detection is checked when the WebMasterONE is powered up. Make sure that the sensor connections are made prior to turning on the power.

Current Temperature

Displays a live reading of the temperature of the system water. If no temperature sensor is detected at power-up, this will be “Manual Temperature” and allow the temperature to be typed into the text box.

Status

Possible status messages are; Normal (everything is OK), Sensor Error (the signal is not valid), High Alarm, or Low Alarm. See section 8.1 for a complete description of error messages.

Calibrate

Click on the “Calibrate” button and a new window will open that read “To Modify the Current Value”, and displays the current reading and a text box in which to type the actual value. Measure the temperature of the sample with a thermometer, and type the actual value into the text box. Click the Submit button. The new value will be displayed. Click the Close button to close the calibrate window.

This menu will not appear if no temperature sensor is detected at power-up.

Temperature Units

Click on the radio button to select units of measure of either Fahrenheit or Celsius.

Uncalibrated Temperature

Displays the temperature reading before correcting with calibration constants. This is helpful for troubleshooting.

This menu will not appear if no temperature sensor is detected at power-up.

High Alarm

In the text box, type the maximum temperature that you would reasonably expect to see for the sample. This is helpful to detect a faulty or poorly calibrated temperature sensor.

This menu will not appear if no temperature sensor is detected at power-up.

Low Alarm

In the text box, type the minimum temperature that you would reasonably expect to see for the sample. This is helpful to detect a faulty or poorly calibrated temperature sensor.

This menu will not appear if no temperature sensor is detected at power-up.

Click on the “Submit” button to save the changes.

6.6 Sensor Menu - ORP Input

Select the option or type in the values that you want for each of the sections on the page. When you click on the “Submit” button at the bottom of the page, your changes will take effect. If you move to another page without clicking “Submit” first, your changes will be lost!

Certain menu sections will only be visible if you have selected certain options in the start up menu.

Type of Sensor

Click the pull-down to select the type of sensor that you have installed. The rest of this section assumes that you have selected ORP.

Custom Name

You can rename the input by typing a custom name in the text box provided. This name will appear as the link to the input page, on the System Summary report, as a choice for relay input assignments, on data logs, and in alarm messages.

Current Reading/Calibrate

The *current reading* is a live reading of the calibrated ORP of the sample.

To *Calibrate* the ORP electrode click on the “Perform Calibration” button and a new window will appear. Select a *2-point calibration*, a *1-point calibration* or a *1-point process calibration* by clicking the appropriate button.

2 Point Calibration

First you will see a warning that ORP control will be suspended during the calibration. Click on “Continue” to start the calibration, or “Cancel” to abort the calibration.

You then be prompted to “Please Rinse the Electrode”. Do so, and then click “Continue”.

You will now be prompted to type in the value of the first standard solution being used. Do so, and then click “Continue”.

You will now see the mV output from the electrode. When this value is stable, click “Continue”.

You then be prompted to “Please Rinse the Electrode”. Do so, and then click “Continue”.

You will now be prompted to type in the value of the second buffer being used. Do so, then click “Continue”.

You will now see the mV output from the electrode. When this value is stable, click “Continue”.

The WebMasterONE will either pass or fail the calibration, and prompt you to return the electrode to the process. Click “Continue” when you are ready for ORP control to resume.

If the calibration fails for any reason, refer to Section 8 for troubleshooting help.

1 Point Calibration

First you will see a warning that ORP control will be suspended during the calibration. Click on “Continue” to start the calibration, or “Cancel” to abort the calibration.

You then be prompted to “Please Rinse the Electrode”. Do so, and then click “Continue”.

You will now be prompted to type in the value of the standard solution being used. Do so, and then click “Continue”.

You will now see the mV output from the electrode. When this value is stable, click “Continue”.

The WebMasterONE will either pass or fail the calibration, and prompt you to return the electrode to the process. Click “Continue” when you are ready for ORP control to resume.

If the calibration fails for any reason, refer to Section 8 for troubleshooting help.

1 Point Process Calibration

The new window will display the current value of the ORP, using the last calibration. Measure the ORP of a sample of the water using a handheld meter, and type the new ORP value in the text box. Click the “Continue” button.

The WebMasterONE will either pass or fail the calibration. Control of the ORP will continue throughout this process.

If the calibration fails for any reason, refer to Section 8 for troubleshooting help.

Status

Possible status messages are; Normal (everything is OK), Sensor Error (the signal is not valid), High Alarm, Low Alarm, Circuit Board Failure or Calibration Time. See section 8.1 for a complete description of error messages.

Date of Last Calibration

This section is for information only, and lets you know when the last calibration occurred.

Calibration Reminder

If you want to be reminded when the electrode needs calibration, for example every 30 days then type the desired number of days between calibration in the text box. A value of zero means you will never be reminded. The highest value allowed is 365 days.

Self Test

The Self Test is used to check the circuitry of the ORP input. Click on the “Self Test” button, and the controller will display either Pass or Fail, and also readings of a simulated ORP. If the controller passes self test, and you are having problems reading the correct ORP or calibrating, then the problem must be with the electrode, wiring or installation.

Uncalibrated Reading

Displays the mV signal from the ORP electrode in the current sample prior to calibration. This is useful for troubleshooting.

Calculated Slope

This displays the slope (change in the mV output of the ORP electrode per expected mV change) of the ORP electrode as of the last calibration. A perfect electrode will have a slope of 1.000. This is helpful for troubleshooting, and also to predict when the electrode may need to be replaced.

Calculated Offset

This displays the mV output of the ORP electrode at 0 mV as of the last calibration. The offset information is helpful for troubleshooting.

High Alarm Limit

Type in the text box the ORP value above which a high ORP alarm will be activated. Any value between -1400 and 1400 is acceptable.

Low Alarm Limit

Type in the text box the ORP value below which a low ORP alarm will be activated. Any value between -1400 and 1400 is acceptable.

Click on the “Submit” button to save the changes.

6.7 Level (4-20 mA) Input Menu

(Only appears if a 4-20 mA input option card is installed, and a Level pull-down is selected in the 4-20 mA Input section of the Start Up page)

Input

Displays which 4-20 mA inputs are defined as level inputs.

Drum

Type in the text box the name of the container the level sensor to the left is measuring.

Volume

This displays the current volume of chemical remaining in that drum.

Raw mA

This displays the mA output of the level transmitter, before it is converted into a volume. This is helpful for troubleshooting.

Status

This displays whether the current drum level is “Normal” or in “Low Alarm”. Possible status messages for level transmitters are; Normal (everything is OK), Sensor Error (the sensor signal is not valid), Over Range (between 20 and 21 mA), Under Range (between 3.9 and 4.0 mA), Low Alarm or Circuit Board Failure.

Full Volume

Type into the text box the volume contained by a full drum.

mA when tank “empty”

Type into the text box the mA output that the level transmitter will send when the drum is empty.

mA when tank “full”

Type into the text box the mA output that the level transmitter will send when the drum is full.

Low Alarm Limit

Type into the text box the volume of chemical remaining in the container at which you want a low alarm to occur.

6.8 Flow Meter (4-20 mA) Input Menu

(Only appears if a 4-20 mA input option card is installed, and a Flow Meter pull-down is selected in the 4-20 mA Input section of the Start Up page)

Input

This column displays all of the 4-20 mA inputs that are defined as Flow Meter type.

Name

Type in the text box the customer name that you may want to give to this flow meter.

Rate

This column will display the flow rate through (or past) the flow meter.

Present mA

This column will display the mA output of the flow meter.

Flow rate at 4 mA

Type the flow rate at which the flow meter will send a 4 mA signal into the text box. This will generally be at 0 gallons or liters/minute.

Flow rate at 20 mA

Type the flow rate at which the water meter will send a 20 mA signal into the text box. This will generally be at the maximum rated flow rate of the meter.

Units

Type the units of measure for the flow rate into the text box.

Low Alarm Limit

Type the flow rate to generate a low alarm error into the text box.

High Alarm Limit

Type the flow rate to generate a high alarm error into the text box.

Click on the “Submit” button to save the changes.

6.9 Generic (4-20 mA) Input Menu

(only appears if a 4-20 mA option card is installed, and a Generic pull-down is selected in the 4-20 mA input section of the Start Up page)

Input

Displays which 4-20 mA inputs have been selected as “Generic” in the 4-20 mA input section of the Start Up page.

Name

Type in the text box a name to describe the device connected to that 4-20 mA input (for example “Pressure”).

Present Value

This displays the current reading of the device, using the mA signal from the device, the span of the 4-20 mA signal defined in “4 mA =” and “20 mA =” below, and the units of measure defined below.

Present mA

This displays the present raw mA signal from the device. This is helpful in troubleshooting.

Status

This displays whether the present value is “Normal”, or in a “Low Alarm” or “High Alarm” condition. Possible status messages are; Normal (everything is OK), Sensor Error (the sensor signal is not valid), Over Range (between 20 and 21 mA), Under Range (between 3.9 and 4.0 mA), High Alarm, Low alarm or Circuit Board Failure. See section 8.1 for a complete description of error messages.

4 mA =

Type into the text box the value that corresponds to a 4 mA output signal from the device. For example, if the pressure transmitter sends out 4 mA at 0.00 psi, type in 0.00. Any value between –10,000 and 10,000 is acceptable.

20 mA =

Type into the text box the value that corresponds to a 20 mA output signal from the device. For example, if the pressure transmitter sends out 20 mA at 100 psi, type in 100. Any value between –10,000 and 10,000 is acceptable.

Units

Type into the text box the units of measure that you want to use for the device connected to that input. For example, you could use “psi”, “Bars”, etc.

Low Alarm Limit

Type into the text box the value for that input below which you want a low alarm to occur. Any value between –10,000 and 10,000 is acceptable.

High Alarm Limit

Type into the text box the value for that input above which you want a high alarm to occur. Any value between –10,000 and 10,000 is acceptable.

6.10 4-20 mA Input Menu

This page is used to assign the purpose of each 4-20 mA input and to calibrate each input.

Status

Possible status messages are Normal (everything is OK), Sensor Error (the sensor signal is not valid), Over Range (between 20 and 21 mA), Under Range (between 3.9 and 4.0 mA), High Alarm, Low Alarm or Circuit Board Failure. See section 8.1 for a complete description of error messages.

4-20 mA Input Assignment Menu

This table is used to reassign the function of the device connected to the input. Click on the pull-down that best describes what is connected to the input. If you assign the inputs on this page, you need to click on the Submit button to see the appropriate menu selections on the page. These are normally already defined in the Start up page.

Not Used should be selected if nothing is connected to that input.

Level should be selected if a *continuous* level transmitter is attached to that output. For *point* level devices, which do not use a 4-20 mA signal, wire into and program with the Digital Inputs section.

Flow Meter should be selected if an analog flow transmitter is connected to that input.

Generic should be selected if the 4-20 mA transmitter connected to that input is anything other than the previously mentioned ones. Later when you re-submit the 4-20 mA Input Page, you will be able to name the input (for example, Phosphate or System Pressure) and also define the Units of Measure (like mg/l or psi).

4-20 mA Input Calibration Menu

This table is used to calibrate the 4-20 mA inputs.

Following the instructions for your 4-20 mA transmitter, supply the WebMasterONE with a 4 mA signal from each transmitter. You should verify that the transmitter is accurate by measuring the output with an ammeter. You can read the present value of the mA signal as measured by the WebMasterONE in the second column of the table. If the present value is not exactly 4 mA, click on the “Set 4 mA” button. You will be asked to verify that you want to change the calibration. Once this is done, the controller will read the transmitter signal as exactly 4 mA.

Repeat this process, supplying the WebMasterONE with a 20 mA signal from each transmitter, and click on the “Set 20 mA” button in order to calibrate the controller.

Click on the “Submit” button to save the changes.

6.11 Flow Meter (Digital) Input Menu

All flow meters connected to digital inputs will be configured in this menu. Each meter will have a separate section. The sections available for a contact meter will differ than those for a paddlewheel meter.

Volume Units

Click on the radio button to select volume in units of *Gallons*, *Liters* or *Cubic Meters*. If you change the units in this screen, changes will not occur on the page until the “Submit” button is pressed.

Custom Name

Type in the text box a name to describe the flow meter.

Total/Reset Total

The Total displays the volume of solution to pass the flow meter since the last time the totalizer was reset.

If you want to reset the total, click on the “Reset Total” button.

Last Total Reset

Displays the date and time that the totalizer was last reset.

Rate (only appears if the water meter type is selected as ‘Paddlewheel’)

Displays the current water flow rate through the water meter.

Status

Possible status messages are; Normal (everything is OK) or Circuit Board Failure (Digital Inputs 1-6 only). See section 8.1 for a complete description of error messages.

Volume per Contact (appears only if the Contact type is selected)

Type the volume of solution that needs to flow through the flow meter before the meter sends a contact into the text box. The controller uses this information to update the totalizer.

K Factor (appears only if the Paddlewheel type is selected)

Type the K factor (number of pulses per unit volume) of your flow meter into the text box. Consult the documentation for the flow meter for information on what the K factor will be for your particular pipe size and installation. The K factor allows the controller to translate pulses from the meter into gallons or liters. Any value between 0.001 and 20,000 is acceptable.

Total Alarm Limit

Type in the text box the total volume of solution to pass the flow meter before setting off an alarm. If you do not need an alarm to occur at any given volume, entering 0 will disable the alarm.

Rate High Alarm (appears only if the Paddlewheel type is selected)

Type in the text box the maximum flow rate above which the alarm will be activated. If no alarm is necessary set this value to a number that is impossible to achieve.

Rate Low Alarm (appears only if the Paddlewheel type is selected)

Type in the text box the minimum flow rate below which the alarm will be activated. If no alarm is necessary set this value to a number that is impossible to achieve.

6.12 Interlock Menu

The Interlock feature allows you to use a contact closure to shut down certain control outputs. For example, a dry contact from a DCS could be sent when the process is shutdown for maintenance, or a flow switch could stop control based upon a stagnant sample.

Digital Inputs

Displays which digital input has been selected as an Interlock input in the digital input section of the Start Up page.

Outputs Interlocked

Click on the check box to the left of the relays that you want to be deactivated when the dry contact signal is received by the controller. Clicking once places a check in the box, clicking again removes the check from the box.

Interlock when contact is

Click on the radio button that describes how your Interlock switch operates. If the contact is open when you want the outputs to deactivate, click on “open”. Otherwise, click on “closed”.

Click on the “Submit” button to save the changes.

6.13 PosiFlow Input Menu

Digital Inputs

Displays which digital inputs have been defined as PosiFlow inputs in the start up page.

Output

Click on the arrow for the pull-down list to tell the controller that the PosiFlow device for the digital input shown to left is attached to the relay that you selected.

Control-Output Status

This column lets you know if the control output for the pump to which the PosiFlow device is attached is currently on or off.

PosiFlow Status

This column lets you know if the PosiFlow is sensing flow from the pump or not.

Vol. per Stroke

Type in the text box the volume of chemical that the metering pump delivers each time it strokes the diaphragm. This information is used to totalize the volume of chemical delivered, by multiplying the volume per stroke by the number of strokes counted by the PosiFlow device.

Alarm Time

Type in the text box the amount of time that can pass between the output relay being activated and the PosiFlow device sensing a stroke of the pump. If the pump is set to deliver 10 strokes per minute, then the controller must wait a minimum of 6 seconds before activating the alarm.

Total

This column tells you the volume of chemical that has been delivered by the metering pump. This value is calculated by multiplying the volume per stroke by the number of strokes counted by the PosiFlow device.

Last Reset Time

This column gives you the date and time that the total was last reset.

Reset Total

Click on the “Reset Total” button to reset the value in the “Total” column back to 0.0.
Click on the “Submit” button to save the changes.

6.14 Level Switches (Digital) Input Menu

Digital Inputs

Displays which digital inputs are defined as level inputs.

Drum

Type in the text box the name of the container the level sensor to the left is measuring.

Status

Displays whether the drum is currently “Low” or “Normal.” Possible status messages for point level switches are; Normal, Low Alarm or Circuit Board Failure (Digital Inputs 1-6 only). See section 8.1 for a complete description of error messages.

Drum Low when Contact is

Click on the radio button that describes how your level switch operates. If the switch is closed when the drum is empty, select “closed”. If the switch is open when the drum is empty, select “open”.

Click on the “Submit” button to save the changes.

6.15 Generic (Digital) Inputs Menu

Digital Inputs

This column shows all digital inputs that have been defined as generic input types.

Custom Name

You may give the input a custom name by typing it in the text box.

Custom Message for Open Contact

You may specify a custom message to be displayed in the System Summary when the digital input contact is open. Type it in the text box.

Custom Message for Closed Contact

You may specify a custom message to be displayed in the System Summary when the digital input contact is closed. Type it in the text box.

Status

This column displays the current status of the digital input using the custom message.

Alarm Active when Contact is

Select the state of the digital input that corresponds to an alarm condition. If Open or Closed is selected, then when the switch is in that state the critical alarm action specified in the Alarm page will occur. If Neither is selected, then neither contact state will initiate the critical alarm action.

6.16 Counter Inputs Menu

Custom Name

You may give the input a custom name by typing it in the text box.

Total

The total number of counts since the last time the total was reset will be displayed here. The Reset Total button allows you to set the total back to 0.

Last Total Reset

The date and time of the last time the total was reset will be displayed here.

Rate

The current rate of contact closures will be displayed here. The unit of measure used is defined below.

Status

This menu reports the status of the input. Possible messages are Normal, High Alarm, Low Alarm, or Total Limit.

Rate Units

Select the units of measure that you want to use using the pull-down. The choices are pulses per second, minute, hour, day, week, month, or year.

One Count =

This menu allows you to specify that each count (contact closure) signifies a certain number of the custom units of measure. For example, one count could equal 100 liters of fluid.

Total Alarm Limit

You may specify a total number of counts accumulated above which an alarm message will occur. Type this in the text box. You must go to the Alarm page to specify that this alarm condition is a critical alarm in order to close the alarm relay or send an email or call a pager.

Rate High Alarm

You may specify a contact rate above which an alarm message will occur. Type this in the text box. You must go to the Alarm page to specify that this alarm condition is a critical alarm in order to close the alarm relay or send an email or call a pager.

Rate Low Alarm

You may specify a contact rate below which an alarm message will occur. Type this in the text box. You must go to the Alarm page to specify that this alarm condition is a critical alarm in order to close the alarm relay or send an email or call a pager.

6.17 Digital Inputs Menu

This page is used to assign the function of the devices attached to each digital input. These are normally already defined in the Start up page.

Use the pull-downs to define each input as *Not Used*, *Contacting Flow Meter*, *Paddlewheel Flow Meter*, *Counter*, *Interlock*, *Level Switch*, *PosiFlow* or *Generic Input*. Click on the “Submit” button to save the changes.

6.18 Relay (1 – 8) Output Menus – On/Off Set Point types

This page is used to select the set point, dead band, etc. Which units of measure appear depends upon how the input assigned to the relay is configured. If you make changes to the Input Assignment, you will need to click on the “Submit” button in order to see all the correct units.

You may also change the Relay Control Mode here. If you do, you will have to reselect the Input Assignment as well.

This section assumes that the Relay Control Mode is set to On/Off Set Point. Other control mode types are described in sections to follow.

Relay Control Mode

Click on the arrow of the pull down menu and select the way that you want to control the relay. See Section 6.2 for details on each control mode.

Relay Input Assignment

Click on the arrow of the pull down menu and select the input that will be used to control the relay. See Section 6.2 for details.

Current Reading

This field is for information only, and will display the calibrated reading from the sensor that is assigned to control the relay.

Status

This menu is for information only, and displays whether the output is “Off” or “On” and if on, for how much time, as well as any alarm conditions. Possible status messages are; Off, Off/Manual, On/Time counting up (if activated based on sensor input), Off/Time counting down/On Delay (if on delay is being used and has not expired yet) or On/Time counting down/Hand (for manual relay activation). Possible error messages are Timeout and Interlock. See section 8.1 for a complete description of error messages.

Reset Timeout

There is a button called “Reset Timeout” which is used to reset the output if it has been activated for longer than the time limit imposed in the “Output Time Limit” menu described below.

Custom Name

This menu allows you to rename the output if desired. Type the new name into the text box.

Set Point

Type in the text box the process value at which you want the relay to activate. The set point value is limited to the range of the assigned input. Click on the link called Scaling to set the range of the 4-20 mA input.

Control Direction

Click on the radio button to select between “Force Lower” or “Force Higher”.

On-Delay

If you want the relay to wait a given amount of time before it activates, set this time in minutes and seconds by typing the value in the text boxes provided.

Dead Band

Type in the text box the process value away from the set point at which the relay will deactivate. For example, if you are forcing the conductivity lower, your set point is 2000 $\mu\text{S}/\text{cm}$, and your dead band is 100 $\mu\text{S}/\text{cm}$, then the relay will activate at 2001 $\mu\text{S}/\text{cm}$ and deactivate at 1900 $\mu\text{S}/\text{cm}$. The purpose of the dead band is to prevent rapid cycling of the relay open and closed, which can shorten its life. The dead band should be set for the lowest value that still prevents the relay from chattering.

Interlock Outputs

Click the check boxes to select or de-select the relays that you want to be forced OFF if this output relay is turned ON. If you do not need any other output to shut off when this relay turns on, UNCHECK all boxes. The selection is mutually exclusive, meaning that if Relay 2 has Relay 4 interlocked, then R2 won't turn on if R4 is on, and R4 won't turn on if R2 is already on. This feature should be used with caution since it can potentially delay a chemical addition for a long time.

Output Time Limit

Type in the text box the maximum amount of time that the relay can be continuously activated before the controller deactivates the relay and activates an Output Time Limit alarm. This is intended to prevent the output from running out of control if the input fails in such a way that it will never deactivate the relay.

Note that the relay will not activate again until someone resets the timer!

It will take some experience to find out what the normal output on-time will be. If the relay cycles open and closed under worst case conditions in 30 minutes, you may want to set the Output Time Limit at 60 minutes.

Hand Time Limit

Type in the text box the maximum number of minutes that the relay can be activated in the Hand mode. Any value between 0 and 1440 is acceptable. A value of 0 means the relay can be left on indefinitely.

Click on the "Submit" button to save the changes.

Output Mode

Click on the radio buttons to manually control the relay. The normal selection will be *Auto*, where the controller uses the various set points to open and close the relay. You can force the relay closed regardless of the set points by selecting *Hand*, or force the relay open regardless of the set points by selecting *Off*.

If you select Off, the relay will not activate again until either Hand or Auto is selected (or if power is cycled)! If you select Hand, the relay will activate until either Auto or Off is selected, or until the Hand Time Limit (programmed in the next menu) expires or until the controller power is cycled.

The Off mode is handy to prevent the relay from activating while you are changing set points. The Hand mode is handy to be able to test the pump or valve, wiring, etc without needing to change set points.

Relay Log

Click on the link to view the relay log. The relay log contains the date and time of each relay activation and deactivation. The data will be a '1' if the relay is closed and a '0' if the relay is open.

A window will open to ask if you would like to open the file or save it to disk. Select the method you would like to use. The file is .csv (comma separated variable) file that will open in a spreadsheet such as Excel.

6.19 Relay (1-8) Output Menus – Time Proportional Types

This page is used to select the set point, proportional band, etc. In time proportional control, the WebMasterONE will look at the process value and compare it to the set point value. If the set point is not satisfied, the controller will calculate an output on-time that will vary in proportion to the deviation from that set point. The user defines the time period, and the proportional band away from the set point where the relay will stay active for the entire time period.

Which units of measure appear depends upon how the input assigned to the relay is configured. If you make changes to the Input Assignment, you will need to click on the “Submit” button in order to see all the correct units.

You may also change the Relay Control Mode here. If you do, you will have to reselect the Input Assignment as well.

This section assumes that the Relay Control Mode is set to Time Proportional. Other control mode types are described in sections to follow.

Relay Control Mode

Click on the arrow of the pull down menu and select the way that you want to control the relay. See Section 6.2 for details on each control mode.

Relay Input Assignment

Click on the arrow of the pull down menu and select the input that will be used to control the relay. See Section 6.2 for details.

Current Reading

This field is for information only, and will display the calibrated reading from the sensor that is assigned to control the relay.

Status

This menu is for information only, and displays whether the output is “Off” or “On” and if on, for how much time, as well as any alarm conditions. Possible status messages are; Off, Off/Manual, On/Time counting up (if activated based on sensor input), or On/Time counting down/Hand (for manual relay activation). Possible error messages are Timeout and Interlock. See Section 8.1 for a complete description of error messages.

Reset Timeout

There is a button called “Reset Timeout” which is used to reset the output if it has been activated for longer than the time limit imposed in the “Output Time Limit” menu described below.

Custom Name

This menu allows you to rename the output if desired. Type the new name into the text box.

Set Point

Type in the text box the process value at which you want the relay to activate. The set point value is limited to the range of the assigned input. Click on the link called Scaling to set the range of the 4-20 mA input.

Sample Period

Type in the text box the time span for the sample period. Refer to the example below under Proportional Band.

Proportional Band

Type in the text box the process value away from the set point at which the relay will be active for the entire sample period.

For example, if you are forcing the conductivity higher, your set point is 200 mS/cm, your sample period is one hour and your proportional band is 10 mS/cm. At the beginning of the sample period, the conductivity is 195 mS/cm. The relay will activate for 30 minutes, then deactivate for 30 minutes. If the conductivity is now 197.5 mS/cm, the relay will activate for 15 minutes and then deactivate for 45 minutes.

Control Direction

Click on the radio button to select between “Force Lower” or “Force Higher.”

Interlock Outputs

Click the check boxes to select or de-select the relays that you want to be forced OFF if this output relay is turned ON. If you do not need any other output to shut off when this relay turns on, UNCHECK all boxes. The selection is mutually exclusive, meaning that if Relay 2 has Relay 4 interlocked, then R2 won't turn on if R4 is on, and R4 won't turn on if R2 is already on. This feature should be used with caution since it can potentially delay a chemical addition for a long time.

Output Time Limit

Type in the text box the maximum amount of time that the relay can be continuously activated before the controller deactivates the relay and activates an Output Time Limit alarm. This is intended to prevent the output from running out of control if the input fails in such a way that it will never deactivate the relay.

Note that the relay will not activate again until someone resets the timer!

It will take some experience to find out what the normal output on-time will be. If the relay cycles open and close under worst case conditions in 30 minutes, you may want to set the Output Time Limit at 60 minutes.

Hand Time Limit

Type in the text box the maximum number of minutes that the relay can be activated in the Hand Mode. Any value between 0 and 1440 is acceptable. A value of 0 means the relay can be left on indefinitely.

Click on the “Submit” button to save the changes.

Output Mode

Click on the radio buttons to manually control the relay. The normal selection will be *Auto*, where the controller uses the various set points to open and close the relay. You can force the relay closed regardless of the set points by selecting *Hand*, or force the relay open regardless of the set points by selecting *Off*.

If you select *Off*, the relay will not activate again until either Hand or Auto is selected (or if power is cycled)! If you select *Hand*, the relay will activate until either Auto or Off is selected, or until the Hand Time Limit (programmed in the next menu) expires or until the controller power is cycled.

The *Off* mode is handy to prevent the relay from activating while you are changing set points. The *Hand* mode is handy to be able to test the pump or valve, wiring, etc. without needing to change set point.

Relay Log

Click on the link to view the relay log. The relay log contains the date and time of each relay activation and deactivation. The data will be a '1' if the relay is closed and a '0' if the relay is open.

A window will open to ask if you would like to open the file or save it to disk. Select the method you would like to use. The file is .csv (comma separated variable) file that will open in a spreadsheet such as Excel.

6.20 Relay (1 – 8) Output Menus – Cycles of Concentration Types

This page is used to activate the relay based on a set point that is the ratio of two conductivity sensor input readings. This option is only available if at least two sensors are defined as conductivity sensors.

You may also change the Relay Control Mode here. If you do, you will have to reselect the Input Assignment as well.

This section assumes that the Relay Control Mode is set to Cycles of Concentration. Other control mode types are described in other sections of the manual.

Relay Control Mode

Click on the arrow of the pull down menu and select the way that you want to control the relay. See Section 6.2 for details on each control mode.

Sys. Cond. Input Assignment

Click on the arrow of the pull down menu to select the conductivity sensor that is installed in the cooling tower water.

Makeup Cond. Input Assignment

Click on the arrow of the pull down menu to select the conductivity sensor that is installed in the makeup water.

System Conductivity

This is a display of the current cooling tower system water conductivity as measured by the assigned sensor.

Makeup Conductivity

This is a display of the current makeup water conductivity as measured by the assigned sensor

Measured Cycles

This is a display of the current ratio of system conductivity to makeup conductivity.

Status

This displays the current status of the relay output, either “Off” or “On”, and if on, the amount of time it has been on. Possible status messages are Off, Off/Manual, On/Time counting down and On/Time counting down/Hand (for manual activation). The only possible error messages are Interlock, Timeout and Sensor Error. See section 8.1 for a complete description of error messages.

Custom Name

This menu allows you to call the output another name if desired. Type the new name in the text box.

Cycles Dead Band

Type in the desired dead band. See Cycles Set Point below.

Cycles Set Point

Type in the desired set point value. The control direction is always a High set point, so if the measured cycles exceeds the set point, the relay will activate until the measured cycles is less than the set point minus dead band.

Cycles Low/High Alarm

Type in the desired alarm points.

Interlock Outputs

Click the check boxes to select or de-select the relays that you want to be forced OFF if this output relay is turned ON. If you do not need any other output to shut off when this relay turns on, UNCHECK all boxes. The selection is mutually exclusive, meaning that if Relay 2 has Relay 4 interlocked, then R2 won't turn on if R4 is on, and R4 won't turn on if R2 is already on. This feature should be used with caution since it can potentially delay a chemical addition for a long time.

Output Time Limit

Type in the text box the maximum amount of time that the relay can be continuously activated before the controller deactivates the relay and activates an Output Time Limit alarm. This is intended to prevent the output from running out of control if the input fails in such a way that it will never deactivate the relay.

Note that the relay will not activate again until someone resets the timer!

It will take some experience to find out what the normal output on-time will be. If the relay cycles open and closed under worst case conditions in 30 minutes, you may want to set the Output Time Limit at 60 minutes.

Output Mode

Click on the radio buttons to manually control the relay. The normal selection will be *Auto*, where the controller uses the various set points to open and close the relay. You can force the relay closed regardless of the set points by selecting *Hand*, or force the relay open regardless of the set points by selecting *Off*.

If you select *Off*, the relay will not activate again until either *Hand* or *Auto* is selected (or if power is cycled)! If you select *Hand*, the relay will activate until either *Auto* or *Off* is selected, or until the *Hand Time Limit* (programmed in the next menu) expires or until the controller power is cycled.

The *Off* mode is handy to prevent the relay from activating while you are changing set points. The *Hand* mode is handy to be able to test the pump or valve, wiring, etc without needing to change set points.

Hand Time Limit

Type in the text box the maximum number of minutes that the relay can be activated in the *Hand* mode. Any value between 0 and 1440 is acceptable. A value of 0 means the relay can be left on indefinitely.

Click on the “Submit” button to save the changes.

Relay Log

Click on the link to view the relay log. The relay log contains the date and time of each relay activation and deactivation. The data will be a ‘1’ if the relay is closed and a ‘0’ if the relay is open.

A window will open to ask if you would like to open the file or save it to disk. Select the method you would like to use. The file is .csv (comma separated variable) file that will open in a spreadsheet such as Excel.

6.21 Relay (1 – 8) Output Menus – Intermittent (Fixed Blowdown Time) Types

This page is used for boiler control where the conductivity is checked at intervals, and if found to be above the set point, the relay is activated for a fixed time. The following sequence occurs while sampling:

The relay activates to open the control valve, allowing a sample of the boiler water to flow past the electrode. The valve remains open for the time programmed in *Duration of Sample*.

The relay deactivates, and closes the control valve. The sample is held in the pipe for the time programmed in *Hold Time*.

At the end of the hold time, the controller reads the conductivity, and compares it to the set point value.

If it is above the set point, the relay activates and opens the valve for the time programmed in *Blowdown Time*.

The valve closes again and the sample is held again.

If the conductivity is still too high, the blowdown time repeats.

This continues until the conductivity is below the set point.

The valve closes and will not reactivate until the *Interval Time* has expired.

You may also change the Relay Control Mode here. If you do, you will have to reselect the Input Assignment as well.

This section assumes that the Relay Control Mode is set to Intermittent (Fixed Blowdown Time). Other control mode types are described in other sections of the manual.

Relay Control Mode

Click on the arrow of the pull down menu and select the way that you want to control the relay. See Section 6.2 for details on each control mode.

Relay Input Assignment

Click on the arrow of the pull down menu to select the sensor to be used to activate this relay.

Current Reading

This is a display of the current process value as measured by the assigned sensor.

Status

This displays the current status of the relay output, either “Off” or “On”, and if on, the amount of time it has been on. Possible status messages are Off, Off/Manual, On/Time counting down/Sampling, Off/Time counting down/Holding, On/Time counting down/Blowdown, Off/Time counting down/Waiting and On/Time counting down/Hand (for manual activation). The only possible error messages are Interlock and Sensor Error. See section 8.1 for a complete description of error messages.

Custom Name

This menu allows you to call the output another name if desired. Type the new name in the text box.

Set Point

Type in the desired set point value. The control direction is always Force Lower.

Interval Time

Type in the desired time between samples. Too short a time will waste water and drop the conductivity well below the set point. Too long a time will cause the conductivity to rise too high, potentially resulting in scale or carryover.

Duration of Sample

Type in the desired sample time. This should be as short as possible while still guarantying a fresh sample of boiler water at the electrode.

Hold Time

Type in the desired time to hold the water sample while it returns to boiler pressure.

Blowdown Time

Type in the desired time to blowdown if the conductivity is above the set point. Too long a time will waste water and drop the conductivity well below the set point. Too short a time could cause the conductivity to rise too high, potentially resulting in scale or carryover.

Interlock Outputs

Click the check boxes to select or de-select the relays that you want to be forced OFF if this output relay is turned ON. If you do not need any other output to shut off when this relay turns on, UNCHECK all boxes. The selection is mutually exclusive, meaning that if Relay 2 has Relay 4 interlocked, then R2 won't turn on if R4 is on, and R4 won't turn on if R2 is already on. This feature should be used with caution since it can potentially delay a chemical addition for a long time.

Output Mode

Click on the radio buttons to manually control the relay. The normal selection will be *Auto*, where the controller uses the various set points to open and close the relay. You can force the relay closed regardless of the set points by selecting *Hand*, or force the relay open regardless of the set points by selecting *Off*.

If you select Off, the relay will not activate again until either Hand or Auto is selected (or if power is cycled)! If you select Hand, the relay will activate until either Auto or Off is selected, or until the Hand Time Limit (programmed in the next menu) expires or until the controller power is cycled.

The Off mode is handy to prevent the relay from activating while you are changing set points. The Hand mode is handy to be able to test the pump or valve, wiring, etc without needing to change set points.

Hand Time Limit

Type in the text box the maximum number of minutes that the relay can be activated in the Hand mode. Any value between 0 and 1440 is acceptable. A value of 0 means the relay can be left on indefinitely.

Click on the "Submit" button to save the changes.

Relay Log

Click on the link to view the relay log. The relay log contains the date and time of each relay activation and deactivation. The data will be a '1' if the relay is closed and a '0' if the relay is open.

A window will open to ask if you would like to open the file or save it to disk. Select the method you would like to use. The file is .csv (comma separated variable) file that will open in a spreadsheet such as Excel.

6.22 Relay (1 – 8) Output Menus – Intermittent (Proportional Blowdown Time) Types

This page is used for boiler control where the conductivity is checked at intervals, and if found to be above the set point, the relay is activated for a time that varies with the conductivity's deviation from the set point.

The following sequence occurs while sampling:

The relay activates to open the control valve, allowing a sample of the boiler water to flow past the electrode. The valve remains open for the time programmed in Duration of Sample.

The relay deactivates, and closes the control valve. The sample is held in the pipe for the time programmed in Hold Time.

At the end of the hold time, the controller reads the conductivity, and compares it to the set point value.

If it is above the set point, the relay activates and opens the valve for the time calculated using the Maximum Blowdown Time and Proportional Band.

The valve closes again and the sample is held again.

If the conductivity is still too high, the blowdown time is recalculated and the valve is opened for that time.

This continues until the conductivity is below the set point.

The valve closes and will not reactivate until the Interval Time has expired.

You may also change the Relay Control Mode here. If you do, you will have to reselect the Input Assignment as well.

This section assumes that the Relay Control Mode is set to Intermittent (Proportional Blowdown Time). Other control mode types are described in other sections of the manual.

Relay Control Mode

Click on the arrow of the pull down menu and select the way that you want to control the relay. See Section 6.2 for details on each control mode.

Relay Input Assignment

Click on the arrow of the pull down menu to select the sensor to be used to activate this relay.

Current Reading

This is a display of the current process value as measured by the assigned sensor.

Status

This displays the current status of the relay output, either “Off” or “On”, and if on, the amount of time it has been on. Possible status messages are Off, Off/Manual, On/Time counting down/Sampling, Off/Time counting down/Holding, On/Time counting down/Blowdown, Off/Time counting down/Waiting and On/Time counting down/Hand (for manual activation). The only possible error messages are Interlock and Sensor Error. See section 8.1 for a complete description of error messages.

Custom Name

This menu allows you to call the output another name if desired. Type the new name in the text box.

Set Point

Type in the desired set point value. The control direction is always Force Lower.

Interval Time

Type in the desired time between samples. Too short a time will waste water and drop the conductivity well below the set point. Too long a time will cause the conductivity to rise too high, potentially resulting in scale or carryover.

Duration of Sample

Type in the desired sample time. This should be as short as possible while still guarantying a fresh sample of boiler water at the electrode.

Hold Time

Type in the desired time to hold the water sample while it returns to boiler pressure.

Blowdown Time

Type in the desired maximum time to blowdown if the conductivity is above the set point. Too long a time will waste water and drop the conductivity well below the set point. Too short a time could cause the conductivity to rise too high, potentially resulting in scale or carryover.

Proportional Band

Type in the conductivity above the set point that will correlate to the maximum blowdown time.

For example, the set point is 2000 $\mu\text{S}/\text{cm}$, the proportional band is 100 $\mu\text{S}/\text{cm}$, and the maximum blowdown time is 30 minutes. If the conductivity measured is 2100 $\mu\text{S}/\text{cm}$ or above, the valve opens for 30 minutes. If the conductivity measured is 2050 $\mu\text{S}/\text{cm}$, the valve opens for 15 minutes. If the conductivity measured is 2000 $\mu\text{S}/\text{cm}$ or below, the valve remains closed and the Interval time counts down.

Interlock Outputs

Click the check boxes to select or de-select the relays that you want to be forced OFF if this output relay is turned ON. If you do not need any other output to shut off when this relay turns on, UNCHECK all boxes. The selection is mutually exclusive, meaning that if Relay 2 has Relay 4 interlocked, then R2 won't turn on if R4 is on, and R4 won't turn on if R2 is already on. This feature should be used with caution since it can potentially delay a chemical addition for a long time.

Output Mode

Click on the radio buttons to manually control the relay. The normal selection will be *Auto*, where the controller uses the various set points to open and close the relay. You can force the relay closed regardless of the set points by selecting *Hand*, or force the relay open regardless of the set points by selecting *Off*.

If you select Off, the relay will not activate again until either Hand or Auto is selected (or if power is cycled)! If you select Hand, the relay will activate until either Auto or Off is selected, or until the Hand Time Limit (programmed in the next menu) expires or until the controller power is cycled.

The Off mode is handy to prevent the relay from activating while you are changing set points. The Hand mode is handy to be able to test the pump or valve, wiring, etc without needing to change set points.

Hand Time Limit

Type in the text box the maximum number of minutes that the relay can be activated in the Hand mode. Any value between 0 and 1440 is acceptable. A value of 0 means the relay can be left on indefinitely.

Click on the "Submit" button to save the changes.

Relay Log

Click on the link to view the relay log. The relay log contains the date and time of each relay activation and deactivation. The data will be a '1' if the relay is closed and a '0' if the relay is open.

A window will open to ask if you would like to open the file or save it to disk. Select the method you would like to use. The file is .csv (comma separated variable) file that will open in a spreadsheet such as Excel.

6.23 Relay (1 - 8) Output Menus – Flow Based Feed Type

This page is used to set the flow volume to trigger feed, feed time, etc. Which units of measure appear depends upon how the flow meter input assigned to the relay is configured. If you make changes to the Input Assignment, you will need to click on the “Submit” button in order to see all the correct units.

You may also change the Relay Control Mode here. If you do, you will have to reselect the Input Assignment as well.

This section assumes that the Relay Control Mode is set to Flow Based Feed. Other control mode types are described in other sections of the manual.

Relay Control Mode

Click on the arrow of the pull down menu and select the way that you want to control the relay. See Section 6.2 for details on each control mode.

Relay Input Assignment

Click on the arrow of the pull down menu and select the input that will be used to control the relay. See Section 6.2 for details.

Accumulated Volume

This displays the volume of flow that has accumulated so far towards triggering the next feed event. This is not the total flow, as seen in the System Summary page. This total will reset itself once the feed has occurred. You can manually reset this total using the “Reset Total” button to the right.

Status

This displays the current status of the Relay Output, either “Off” or “On”, and if on, the time it has been on and any alarm conditions. Possible status messages are Off, Off/manual, On/Time counting down, Off/Time counting down/On Delay (if on delay is being used and has not expired yet) or On/Time counting down/Hand (for manual relay activation). Possible error messages are Timeout, Interlock, or Pump Failure. See section 8.1 for a complete description of error messages.

Custom Name

This menu allows you to call the output another name if desired. Type the new name in the text box.

Unit Volume to Trigger Output

Type in the text box the volume of solution that needs to enter the system in order to trigger the feed.

Output On-Time Per Unit Volume

Type in the text box the amount of time for the relay output to activate, once the previously specified volume of solution has entered the system. Any value between 1 and 1440 minutes is acceptable.

Reset Timeout

(only appears if the Output Time Limit below has been exceeded)

There is a button called “Reset Timeout” which is used to reset the output if it has been activated for longer than the time limit imposed in the “Output Time Limit” menu described below.

Interlock Outputs

Click the check boxes to select or de-select the relays that you want to be forced OFF if this output relay is turned ON. If you do not need any other output to shut off when this relay turns on, UNCHECK all boxes. The selection is mutually exclusive, meaning that if Relay 2 has Relay 4 interlocked, then R2 won't turn on if R4 is on, and R4 won't turn on if R2 is already on. This feature should be used with caution since it can potentially delay a chemical addition for a long time.

Output Time Limit

Type in the text box the maximum amount of time that the relay can be continuously activated before the controller deactivates the relay and activates an Output Time Limit alarm. This is intended to prevent the output from running out of control if the input fails in such a way that it will never deactivate the relay.

Note that the relay will not activate again until someone resets the timer!

It will take some experience to find out what the normal output on-time will be. If the relay cycles open and closed under worst case conditions in 30 minutes, you may want to set the Output Time Limit at 60 minutes.

Hand Time Limit

Type in the text box the maximum number of minutes that the relay can be activated in the Hand mode. Any value between 0 and 1440 is acceptable. A value of 0 means the relay can be left on indefinitely.

Click on the “Submit” button to save the changes.

Output Mode

Click on the radio buttons to manually control the relay. The normal selection will be *Auto*, where the controller uses the various set points to open and close the relay. You can force the relay closed regardless of the set points by selecting *Hand*, or force the relay open regardless of the set points by selecting *Off*.

If you select Off, the relay will not activate again until either Hand or Auto is selected (or if power is cycled)! If you select Hand, the relay will activate until either Auto or Off is selected, or until the Hand Time Limit (programmed in the next menu) expires or until the controller power is cycled.

The Off mode is handy to prevent the relay from activating while you are changing set points. The Hand mode is handy to be able to test the pump or valve, wiring, etc without needing to change set points.

Click on the “Submit” button to save the changes.

Relay Log

Click on the link to view the relay log. The relay log contains the date and time of each relay activation and deactivation. The data will be a ‘1’ if the relay is closed and a ‘0’ if the relay is open.

A window will open to ask if you would like to open the file or save it to disk. Select the method you would like to use. The file is .csv (comma separated variable) file that will open in a spreadsheet such as Excel.

6.24 Relay (1-8) Output Menus – Feed With Another Relay Types

This page is used for relays that will be activated at the same time as another relay.

You may also change the Relay Control Mode here. If you do, you will have to reselect the Input Assignment as well.

This section assumes that the Relay Control Mode is set to Feed With Another Relay. Other control mode types are described in other sections of the manual.

Relay Control Mode

Click on the arrow of the pull down menu and select the way that you want to control the relay. See Section 6.2 for details on each control mode.

Assign Relay to Feed With

Click on the arrow of the pull down menu and select the relay that will be used to control this relay.

Status

This displays the current status of the relay output, either “Off” or “On”, and if on, the amount of time it has been on. Possible status messages are Off, Off/Manual, On/Time counting down and On/Time counting down/Hand (for manual activation). The only possible error message is Interlock. See section 8.1 for a complete description of error messages.

Custom Name

This menu allows you to call the output another name if desired. Type the new name in the text box.

Interlock Outputs

Click the check boxes to select or de-select the relays that you want to be forced OFF if this output relay is turned ON. If you do not need any other output to shut off when this relay turns on, UNCHECK all boxes. The selection is mutually exclusive, meaning that if Relay 2 has Relay 4 interlocked, then R2 won't turn on if R4 is on, and R4 won't turn on if R2 is already on. This feature should be used with caution since it can potentially delay a chemical addition for a long time.

Output Time Limit

Type in the text box the maximum amount of time that the relay can be continuously activated before the controller deactivates the relay and activates an Output Time Limit alarm. This is intended to prevent the output from running out of control if the input fails in such a way that it will never deactivate the relay.

Note that the relay will not activate again until someone resets the timer!

It will take some experience to find out what the normal output on-time will be. If the relay cycles open and closed under worst case conditions in 30 minutes, you may want to set the Output Time Limit at 60 minutes.

Output Mode

Click on the radio buttons to manually control the relay. The normal selection will be *Auto*, where the controller uses the various set points to open and close the relay. You can force the relay closed regardless of the set points by selecting *Hand*, or force the relay open regardless of the set points by selecting *Off*.

If you select *Off*, the relay will not activate again until either *Hand* or *Auto* is selected (or if power is cycled)! If you select *Hand*, the relay will activate until either *Auto* or *Off* is selected, or until the *Hand Time Limit* (programmed in the next menu) expires or until the controller power is cycled.

The *Off* mode is handy to prevent the relay from activating while you are changing set points. The *Hand* mode is handy to be able to test the pump or valve, wiring, etc without needing to change set points.

Hand Time Limit

Type in the text box the maximum number of minutes that the relay can be activated in the *Hand* mode. Any value between 0 and 1440 is acceptable. A value of 0 means the relay can be left on indefinitely.

Click on the "Submit" button to save the changes.

Relay Log

Click on the link to view the relay log. The relay log contains the date and time of each relay activation and deactivation. The data will be a '1' if the relay is closed and a '0' if the relay is open.

A window will open to ask if you would like to open the file or save it to disk. Select the method you would like to use. The file is .csv (comma separated variable) file that will open in a spreadsheet such as Excel.

6.25 Relay (1 – 8) Output Menus – Feed After Another Relay (%) Types

This page is used to program to activate one relay for a percentage of the time that another relay had been activated. The first relay will activate, and its on-time recorded. When the first relay shuts off, the total on-time is calculated, and this relay is activated for the correct percentage of that time. If you make changes to the Input Assignment, you will need to click on the “Submit” button in order to see all the correct units.

You may also change the Relay Control Mode here. If you do, you will have to reselect the Input Assignment as well.

This section assumes that the Relay Control Mode is set to Feed After Another Relay. Other control mode types are described in other sections of the manual.

Relay Control Mode

Click on the arrow of the pull down menu and select the way that you want to control the relay. See Section 6.2 for details on each control mode.

Assign Relay to Feed After

Click on the arrow of the pull down menu and select the relay that will be used to control this relay.

Status

This displays the current status of the relay output, either “Off” or “On”, and if on, the amount of time it has been on. Possible status messages are Off, Off/Manual, On/Time counting down and On/Time counting down/Hand (for manual activation). The only possible error message is Interlock. See section 8.1 for a complete description of error messages.

Custom Name

This menu allows you to call the output another name if desired. Type the new name in the text box.

% of Relay to Feed

Use this menu to type in percentage of the assigned relay’s on-time desired for this relay.

Interlock Outputs

Click the check boxes to select or de-select the relays that you want to be forced OFF if this output relay is turned ON. If you do not need any other output to shut off when this relay turns on, UNCHECK all boxes. The selection is mutually exclusive, meaning that if Relay 2 has Relay 4 interlocked, then R2 won’t turn on if R4 is on, and R4 won’t turn on if R2 is already on. This feature should be used with caution since it can potentially delay a chemical addition for a long time.

Output Time Limit

Type in the text box the maximum amount of time that the relay can be continuously activated before the controller deactivates the relay and activates an Output Time Limit alarm. This is intended to prevent the output from running out of control if the input fails in such a way that it will never deactivate the relay.

Note that the relay will not activate again until someone resets the timer!

It will take some experience to find out what the normal output on-time will be. If the relay cycles open and closed under worst case conditions in 30 minutes, you may want to set the Output Time Limit at 60 minutes.

Output Mode

Click on the radio buttons to manually control the relay. The normal selection will be *Auto*, where the controller uses the various set points to open and close the relay. You can force the relay closed regardless of the set points by selecting *Hand*, or force the relay open regardless of the set points by selecting *Off*.

If you select *Off*, the relay will not activate again until either *Hand* or *Auto* is selected (or if power is cycled)! If you select *Hand*, the relay will activate until either *Auto* or *Off* is selected, or until the Hand Time Limit (programmed in the next menu) expires or until the controller power is cycled.

The *Off* mode is handy to prevent the relay from activating while you are changing set points. The *Hand* mode is handy to be able to test the pump or valve, wiring, etc without needing to change set points.

Hand Time Limit

Type in the text box the maximum number of minutes that the relay can be activated in the *Hand* mode. Any value between 0 and 1440 is acceptable. A value of 0 means the relay can be left on indefinitely.

Click on the “Submit” button to save the changes.

Relay Log

Click on the link to view the relay log. The relay log contains the date and time of each relay activation and deactivation. The data will be a ‘1’ if the relay is closed and a ‘0’ if the relay is open.

A window will open to ask if you would like to open the file or save it to disk. Select the method you would like to use. The file is .csv (comma separated variable) file that will open in a spreadsheet such as Excel.

6.26 Relay (1-8) Output Menus – Feed After Another Relay (Fixed Time)

This page is used to program to activate one relay after another relay has been activated. The first relay will activate. When the first relay shuts off the second relay will activate for a programmable amount of time. If you make changes to the Input Assignment, you will need to click on the “Submit” button in order to see all the correct units.

You may also change the Relay Control Mode here. If you do, you will have to reselect the Input Assignment as well.

This section assumes that the Relay Control Mode is set to Feed After Another Relay (Fixed Time). Other control mode types are described in other sections of the manual.

Relay Control Mode

Click on the arrow of the pull down menu and select the way that you want to control the relay. See Section 6.2 for details on each control mode.

Assign Relay to Feed After

Click on the arrow of the pull down menu and select the relay that will be used to control this relay.

Status

This displays the current status of the relay output, either “Off” or “On”, and if on, the amount of time it has been on. Possible status messages are Off, Off/Manual, On/Time counting down and On/Time counting down/Hand (for manual activation). The only possible error message is Interlock. See section 8.1 for a complete description of error messages.

Custom Name

This menu allows you to call the output another name if desired. Type the new name in the text box.

Fixed Time to Feed

Use this menu to type the minutes and seconds of this relay’s on-time.

Interlock Outputs

Click the check boxes to select or de-select the relays that you want to be forced OFF if this output relay is turned ON. If you do not need any other output to shut off when this relay turns on, UNCHECK all boxes. The selection is mutually exclusive, meaning that if Relay 2 has Relay 4 interlocked, then R2 won’t turn on if R4 is on, and R4 won’t turn on if R2 is already on. This feature should be used with caution since it can potentially delay a chemical addition for a long time.

Output Time Limit

Type in the text box the maximum amount of time that the relay can be continuously activated before the controller deactivates the relay and activates an Output Time Limit alarm. This is intended to prevent the output from running out of control if the input fails in such a way that it will never deactivate the relay.

Note that the relay will not activate again until someone resets the timer!

It will take some experience to find out what the normal output on-time will be. If the relay cycles open and closed under worst case conditions in 30 minutes, you may want to set the Output Time Limit at 60 minutes.

Output Mode

Click on the radio buttons to manually control the relay. The normal selection will be *Auto*, where the controller uses the various set points to open and close the relay. You can force the relay closed regardless of the set points by selecting *Hand*, or force the relay open regardless of the set points by selecting *Off*.

If you select *Off*, the relay will not activate again until either *Hand* or *Auto* is selected (or if power is cycled)! If you select *Hand*, the relay will activate until either *Auto* or *Off* is selected, or until the Hand Time Limit (programmed in the next menu) expires or until the controller power is cycled.

The *Off* mode is handy to prevent the relay from activating while you are changing set points. The *Hand* mode is handy to be able to test the pump or valve, wiring, etc without needing to change set points.

Hand Time Limit

Type in the text box the maximum number of minutes that the relay can be activated in the *Hand* mode. Any value between 0 and 1440 is acceptable. A value of 0 means the relay can be left on indefinitely.

Click on the “Submit” button to save the changes.

Relay Log

Click on the link to view the relay log. The relay log contains the date and time of each relay activation and deactivation. The data will be a ‘1’ if the relay is closed and a ‘0’ if the relay is open.

A window will open to ask if you would like to open the file or save it to disk. Select the method you would like to use. The file is .csv (comma separated variable) file that will open in a spreadsheet such as Excel.

6.27 Relay (1 – 8) Output Menus – Feed as % of Time Types

This page is used to program to activate one relay for a percentage of a user-specified time period.

You may also change the Relay Control Mode here. If you do, you will have to reselect the Input Assignment as well.

This section assumes that the Relay Control Mode is set to Feed as % of Time. Other control mode types are described in other sections of the manual.

Relay Control Mode

Click on the arrow of the pull down menu and select the way that you want to control the relay. See Section 6.2 for details on each control mode.

Status

This displays the current status of the relay output, either “Off” or “On”, and if on, the amount of time it has been on. Possible status messages are Off, Off/Manual, On/Time counting down and On/Time counting down/Hand (for manual activation). The only possible error message is Interlock. See section 8.1 for a complete description of error messages.

Custom Name

This menu allows you to call the output another name if desired. Type the new name in the text box.

Time Period

Type in the desired time period, between 1 and 1440 minutes. The relay will activate at the beginning of the time period, for the percentage of it specified below.

% of Period to Feed

Use this menu to type in the percentage of the time period that this relay will be active.

Interlock Outputs

Click the check boxes to select or de-select the relays that you want to be forced OFF if this output relay is turned ON. If you do not need any other output to shut off when this relay turns on, UNCHECK all boxes. The selection is mutually exclusive, meaning that if Relay 2 has Relay 4 interlocked, then R2 won't turn on if R4 is on, and R4 won't turn on if R2 is already on. This feature should be used with caution since it can potentially delay a chemical addition for a long time.

Output Time Limit

Type in the text box the maximum amount of time that the relay can be continuously activated before the controller deactivates the relay and activates an Output Time Limit alarm. This is intended to prevent the output from running out of control if the input fails in such a way that it will never deactivate the relay.

Note that the relay will not activate again until someone resets the timer!

It will take some experience to find out what the normal output on-time will be. If the relay cycles open and closed under worst case conditions in 30 minutes, you may want to set the Output Time Limit at 60 minutes.

Output Mode

Click on the radio buttons to manually control the relay. The normal selection will be *Auto*, where the controller uses the various set points to open and close the relay. You can force the relay closed regardless of the set points by selecting *Hand*, or force the relay open regardless of the set points by selecting *Off*.

If you select Off, the relay will not activate again until either Hand or Auto is selected (or if power is cycled)! If you select Hand, the relay will activate until either Auto or Off is selected, or until the Hand Time Limit (programmed in the next menu) expires or until the controller power is cycled.

The Off mode is handy to prevent the relay from activating while you are changing set points. The Hand mode is handy to be able to test the pump or valve, wiring, etc without needing to change set points.

Hand Time Limit

Type in the text box the maximum number of minutes that the relay can be activated in the Hand mode. Any value between 0 and 1440 is acceptable. A value of 0 means the relay can be left on indefinitely.

Click on the “Submit” button to save the changes.

Relay Log

Click on the link to view the relay log. The relay log contains the date and time of each relay activation and deactivation. The data will be a ‘1’ if the relay is closed and a ‘0’ if the relay is open.

A window will open to ask if you would like to open the file or save it to disk. Select the method you would like to use. The file is .csv (comma separated variable) file that will open in a spreadsheet such as Excel.

6.28 Relay (1 – 8) Output Menus – Biocide Timer Based Types

This page is used to set the day and time to trigger feed, feed time, etc.

You may also change the Relay Control Mode here. If you do, you will have to reselect the Input Assignment as well.

This section assumes that the Relay Control Mode is set to Daily Biocide Timer, 1 Week Biocide Timer, 2 Week Biocide Timer, or 4 Week Biocide Timer. Other control mode types are described in other sections of the manual.

Relay Control Mode

Click on the arrow of the pull down menu and select the way that you want to control the relay. See Section 6.2 for details on each control mode.

Relay Input Assignment

Click on the arrow of the pull down menu and select the input that will be used to control the relay. See Section 6.2 for details. Biocide timers do not have an input assigned, they are activated based on a calendar.

Status

This displays the current status of the relay output, either “Off” or “On” and if on, the time it has been on and any alarm conditions. When the output is Off, the time until the next scheduled addition will be counting down. Possible status messages are Off., Off/Pending (time to add has come but output is interlocked), Off/manual, On/Time counting down or On/Time counting down/Hand (for manual relay activation). The only possible error message is Interlock. See section 8.1 for a complete description of error messages.

Custom Name

This menu allows you to call the output another name if desired. Type the new name in the text box.

Week 1-4 Schedule

(only appears if the Relay Control Mode is selected as Weekly, Bi-Weekly, or Monthly)

Day of Week: Click on the check box next to the days of the week during which you want a relay activation to occur. If a box is checked and you don't want an addition that day, click it to un-check the box.

Time: Type in the text boxes the hour and minute for the addition to occur. Use the arrow for the pull down menu to select between AM and PM.

On Time: Type in the text box the amount of time that you want the relay to be activated. Any value between 1 and 1440 is acceptable.

For Bi-Weekly or Monthly Modes, repeat this process for each week in the cycle.

Daily Schedule

(only appears if the Relay Control Mode is selected as Daily)

Additions: Click on the check box next to the additions that you want to occur every day. For example, if you want to activate the relay 4 times per day, check Additions A through D. If a check is in a box and you don't want that addition to happen, click on the box to un-check it.

Time: Type in the text boxes the hour and minute for the addition to occur. Use the arrow for the pull down menu to select between AM and PM.

On Time: Type in the text box the amount of time that you want the relay output to be active when it makes its addition. Any value between 1 and 1440 is acceptable.

Assign Bleed Lockout Relay

If you want to lockout bleed after the biocide addition, click on the arrow for the pull down menu and select the relay you have configured as the bleed relay (normally R1).

Bleed Lockout Time

If you want to lockout bleed after the biocide addition, type the desired lockout time (in minutes) in this text box.

Prebleed Type

If you want to bleed the system to drop the conductivity prior to the biocide addition, click on the radio button and select the method of prebleed desired.

Select **Not Used** if no prebleed is desired.

Select **Time Based** to open the bleed valve for a fixed amount of time prior to each biocide addition.

Select **Conductivity Based** to bleed until a conductivity set point is achieved prior to each biocide addition.

Assign Prebleed Relay (only appears if Prebleed is Used)

Click on the arrow of the pull down menu to select which relay is used for the Bleed function (normally R1).

Assign Prebleed Conductivity Input (only appears if Prebleed is Conductivity Based)

Click on the arrow of the pull down menu to select the sensor input which is used for system conductivity (normally S1).

Prebleed Conductivity (only appears if Prebleed is Conductivity Based)

Type the conductivity set point for the prebleed into the text box. This should be less than the normal bleed set point.

Prebleed Time Limit (only appears if Prebleed is Conductivity Based)

A time limit may be imposed on the conductivity based prebleed. If a system problem such as a faulty conductivity sensor or bleed valve prevents the prebleed conductivity from being achievable, the time limit will trigger the biocide add to occur.

Prebleed Time (only appears if Prebleed is Time Based)

Type the desired prebleed time (in minutes) in the text box.

Dispersant Addition

If you want to feed another chemical, such as a dispersant, penetrant or surfactant prior to the biocide addition, click on the radio button and select the method desired.

Select **Not Used** if no dispersant addition is desired.

Select **Before Biocide** to activate the dispersant relay for fixed amount of time prior to each biocide addition.

Select **After Biocide** to activate the dispersant relay for fixed amount of time after each biocide addition.

Assign Dispersant Relay

Click the arrow of the pull down menu to select the relay that will be used to feed the dispersant.

Interlock Outputs

Click the check boxes to select or de-select the relays that you want to be forced OFF if this output relay is turned ON. If you do not need any other output to shut off when this relay turns on, UNCHECK all boxes. The selection is mutually exclusive, meaning that if Relay 2 has Relay 4 interlocked, then R2 won't turn on if R4 is on, and R4 won't turn on if R2 is already on. This feature should be used with caution since it can potentially delay a chemical addition for a long time.

Output Mode

Click on the radio buttons to manually control the relay. The normal selection will be *Auto*, where the controller uses the various set points to open and close the relay. You can force the relay closed regardless of the set points by selecting *Hand*, or force the relay open regardless of the set points by selecting *Off*.

If you select Off, the relay will not activate again until either Hand or Auto is selected (or if power is cycled)! If you select Hand, the relay will activate until either Auto or Off is selected, or until the Hand Time Limit (programmed in the next menu) expires or until the controller power is cycled.

The Off mode is handy to prevent the relay from activating while you are changing set points. The Hand mode is handy to be able to test the pump or valve, wiring, etc without needing to change set points.

Hand Time Limit

Type in the text box the maximum number of minutes that the relay can be activated in the Hand mode. Any value between 0 and 1440 is acceptable. A value of 0 means the relay can be left on indefinitely.

Click on the “Submit” button to save the changes.

Relay Log

Click on the link to view the relay log. The relay log contains the date and time of each relay activation and deactivation. The data will be a ‘1’ if the relay is closed and a ‘0’ if the relay is open.

A window will open to ask if you would like to open the file or save it to disk. Select the method you would like to use. The file is .csv (comma separated variable) file that will open in a spreadsheet such as Excel.

6.29 Relay (1 – 8) Output Menus – Spike Set Point Types

This page is used to activate the relay based on one set point for a majority of the time, and then spiking the concentration for a programmable amount of time, as often as once per day, on a one week, 2 week or 4 week schedule. This is typically an oxidizer addition based on an ORP electrode.

You may also change the Relay Control Mode here. If you do, you will have to reselect the Input Assignment as well.

This section assumes that the Relay Control Mode is set to Spike Set Point (1, 2 or 4 week cycle). Other control mode types are described in other sections of the manual.

Relay Control Mode

Click on the arrow of the pull down menu and select the way that you want to control the relay. See Section 6.2 for details on each control mode.

Relay Input Assignment

Click on the arrow of the pull down menu to select the sensor to be used to activate this relay.

Current Reading

This is a display of the current process value as measured by the assigned sensor.

Status

This displays the current status of the relay output, either “Off” or “On”, and if on, the amount of time it has been on. Possible status messages are Off, Off/Manual, On/Time counting down and On/Time counting down/Hand (for manual activation). The only possible error messages are Interlock, Timeout and Sensor Error. See section 8.1 for a complete description of error messages.

Custom Name

This menu allows you to call the output another name if desired. Type the new name in the text box.

Set Point

Type in the desired set point value. The control direction is selected below.

Dead Band

Type in the desired dead band. See Set Point above.

Spike Point

Type in the desired set point value for the spike in concentration.

Week 1-4 Schedule

Day of Week: Click on the check box next to the days of the week during which you want a relay activation to occur. If a box is checked and you don't want an addition that day, click it to un-check the box.

Time: Type in the text boxes the hour and minute for the addition to occur. Use the arrow for the pull down menu to select between AM and PM.

On Time: Type in the text box the amount of time that you want the relay to be activated. Any value between 1 and 1440 is acceptable.

For Bi-Weekly or Monthly Modes, repeat this process for each week in the cycle.

Control Direction

Click on the appropriate radio button. If the sensor reading naturally drops, and you want to bring it back up, select Force Higher.

Interlock Outputs

Click the check boxes to select or de-select the relays that you want to be forced OFF if this output relay is turned ON. If you do not need any other output to shut off when this relay turns on, UNCHECK all boxes. The selection is mutually exclusive, meaning that if Relay 2 has Relay 4 interlocked, then R2 won't turn on if R4 is on, and R4 won't turn on if R2 is already on. This feature should be used with caution since it can potentially delay a chemical addition for a long time.

Output Time Limit

Type in the text box the maximum amount of time that the relay can be continuously activated before the controller deactivates the relay and activates an Output Time Limit alarm. This is intended to prevent the output from running out of control if the input fails in such a way that it will never deactivate the relay.

Note that the relay will not activate again until someone resets the timer!

It will take some experience to find out what the normal output on-time will be. If the relay cycles open and closed under worst case conditions in 30 minutes, you may want to set the Output Time Limit at 60 minutes.

Output Mode

Click on the radio buttons to manually control the relay. The normal selection will be *Auto*, where the controller uses the various set points to open and close the relay. You can force the relay closed regardless of the set points by selecting *Hand*, or force the relay open regardless of the set points by selecting *Off*.

If you select *Off*, the relay will not activate again until either *Hand* or *Auto* is selected (or if power is cycled)! If you select *Hand*, the relay will activate until either *Auto* or *Off* is selected, or until the Hand Time Limit (programmed in the next menu) expires or until the controller power is cycled.

The *Off* mode is handy to prevent the relay from activating while you are changing set points. The *Hand* mode is handy to be able to test the pump or valve, wiring, etc without needing to change set points.

Hand Time Limit

Type in the text box the maximum number of minutes that the relay can be activated in the *Hand* mode. Any value between 0 and 1440 is acceptable. A value of 0 means the relay can be left on indefinitely.

Click on the “Submit” button to save the changes.

Relay Log

Click on the link to view the relay log. The relay log contains the date and time of each relay activation and deactivation. The data will be a ‘1’ if the relay is closed and a ‘0’ if the relay is open.

A window will open to ask if you would like to open the file or save it to disk. Select the method you would like to use. The file is .csv (comma separated variable) file that will open in a spreadsheet such as Excel.

6.30 Relay (1 – 8) Output Menus – Dispersant Types

This page is used to activate the relay either before or after a Biocide Timer relay activates. This is normally used to feed a Dispersant, Penetrant or Surfactant to a cooling tower.

You may also change the Relay Control Mode here. If you do, you will have to reselect the Input Assignment as well.

This section assumes that the Relay Control Mode is set to Dispersant. Other control mode types are described in other sections of the manual.

Relay Control Mode

Click on the arrow of the pull down menu and select the way that you want to control the relay. See Section 6.2 for details on each control mode.

Relay Input Assignment

Click on the arrow of the pull down menu to select the input to be used to activate this relay. In dispersant mode, this is not applicable, the relay is activated directly before or after a biocide timer based relay.

Status

This displays the current status of the relay output, either “Off” or “On”, and if on, the amount of time it has been on. Possible status messages are Off, Off/Manual, On/Time counting down and On/Time counting down/Hand (for manual activation). The only possible error messages are Interlock, Timeout and Sensor Error. See section 8.1 for a complete description of error messages.

Custom Name

This menu allows you to call the output another name if desired. Type the new name in the text box.

On Time

Type the amount of feed time desired (in minutes) in the text box.

Interlock Outputs

Click the check boxes to select or de-select the relays that you want to be forced OFF if this output relay is turned ON. If you do not need any other output to shut off when this relay turns on, UNCHECK all boxes. The selection is mutually exclusive, meaning that if Relay 2 has Relay 4 interlocked, then R2 won't turn on if R4 is on, and R4 won't turn on if R2 is already on. This feature should be used with caution since it can potentially delay a chemical addition for a long time.

Output Time Limit

Type in the text box the maximum amount of time that the relay can be continuously activated before the controller deactivates the relay and activates an Output Time Limit alarm. This is intended to prevent the output from running out of control if the input fails in such a way that it will never deactivate the relay.

Note that the relay will not activate again until someone resets the timer!

It will take some experience to find out what the normal output on-time will be. If the relay cycles open and closed under worst case conditions in 30 minutes, you may want to set the Output Time Limit at 60 minutes.

Output Mode

Click on the radio buttons to manually control the relay. The normal selection will be *Auto*, where the controller uses the various set points to open and close the relay. You can force the relay closed regardless of the set points by selecting *Hand*, or force the relay open regardless of the set points by selecting *Off*.

If you select *Off*, the relay will not activate again until either *Hand* or *Auto* is selected (or if power is cycled)! If you select *Hand*, the relay will activate until either *Auto* or *Off* is selected, or until the Hand Time Limit (programmed in the next menu) expires or until the controller power is cycled.

The *Off* mode is handy to prevent the relay from activating while you are changing set points. The *Hand* mode is handy to be able to test the pump or valve, wiring, etc without needing to change set points.

Hand Time Limit

Type in the text box the maximum number of minutes that the relay can be activated in the *Hand* mode. Any value between 0 and 1440 is acceptable. A value of 0 means the relay can be left on indefinitely.

Click on the “Submit” button to save the changes.

Relay Log

Click on the link to view the relay log. The relay log contains the date and time of each relay activation and deactivation. The data will be a ‘1’ if the relay is closed and a ‘0’ if the relay is open.

A window will open to ask if you would like to open the file or save it to disk. Select the method you would like to use. The file is .csv (comma separated variable) file that will open in a spreadsheet such as Excel.

6.31 Relay (1-8) Output Menus - Bleed Volume based on Makeup Volume

This page is used to activate the relay until a programmed volume of water flows through the bleed water meter(s). The relay activation is triggered by a programmed volume of makeup water flowing through the makeup water meter(s)

You may also change the Relay Control Mode here. If you do, you will have to reselect the Input Assignment as well.

This section assumes that the Relay Control Mode is set to Bleed Volume based on Makeup Volume. Other control mode types are described in other sections of the manual.

Relay Control Mode

Click on the arrow of the pull down menu and select the way that you want to control the relay. See Section 6.2 for details on each control mode.

Assign Makeup Meter 1, 2 or 3

Click on the arrow of the pull down menu to select the flow meter input to be used to activate this relay. Up to 3 flow meters may be assigned.

Assign Bleed Meter 1 or 2

Click on the arrow of the pull down menu to select the flow meter input to be used to activate this relay. Up to 3 flow meters may be assigned.

Status

This displays the current status of the relay output, either “Off” or “On”, and if on, the amount of time it has been on. Possible status messages are Off, Off/Manual, On/Time counting down and On/Time counting down/Hand (for manual activation). The only possible error messages are Interlock, Timeout and Sensor Error. See section 8.1 for a complete description of error messages.

Custom Name

This menu allows you to call the output another name if desired. Type the new name in the text box.

Accumulated Makeup

This displays the volume of makeup water that has accumulated since the last time the relay activated.

Accumulated Bleed

This displays the volume of bleed that has accumulated since the last time the relay activated.

Bleed Volume per Makeup Volume

Type the amount of water to bleed after the amount of makeup water comes in that is programmed below.

Makeup Volume

Type the amount of makeup water that will trigger the bleed relay.

Interlock Outputs

Click the check boxes to select or de-select the relays that you want to be forced OFF if this output relay is turned ON. If you do not need any other output to shut off when this relay turns on, UNCHECK all boxes. The selection is mutually exclusive, meaning that if Relay 2 has Relay 4 interlocked, then R2 won't turn on if R4 is on, and R4 won't turn on if R2 is already on. This feature should be used with caution since it can potentially delay a chemical addition for a long time.

Output Time Limit

Type in the text box the maximum amount of time that the relay can be continuously activated before the controller deactivates the relay and activates an Output Time Limit alarm. This is intended to prevent the output from running out of control if the input fails in such a way that it will never deactivate the relay.

Note that the relay will not activate again until someone resets the timer!

It will take some experience to find out what the normal output on-time will be. If the relay cycles open and closed under worst case conditions in 30 minutes, you may want to set the Output Time Limit at 60 minutes.

Output Mode

Click on the radio buttons to manually control the relay. The normal selection will be *Auto*, where the controller uses the various set points to open and close the relay. You can force the relay closed regardless of the set points by selecting *Hand*, or force the relay open regardless of the set points by selecting *Off*.

If you select *Off*, the relay will not activate again until either *Hand* or *Auto* is selected (or if power is cycled)! If you select *Hand*, the relay will activate until either *Auto* or *Off* is selected, or until the Hand Time Limit (programmed in the next menu) expires or until the controller power is cycled.

The *Off* mode is handy to prevent the relay from activating while you are changing set points. The *Hand* mode is handy to be able to test the pump or valve, wiring, etc without needing to change set points.

Hand Time Limit

Type in the text box the maximum number of minutes that the relay can be activated in the *Hand* mode. Any value between 0 and 1440 is acceptable. A value of 0 means the relay can be left on indefinitely.

Click on the “Submit” button to save the changes.

Relay Log

Click on the link to view the relay log. The relay log contains the date and time of each relay activation and deactivation. The data will be a ‘1’ if the relay is closed and a ‘0’ if the relay is open.

A window will open to ask if you would like to open the file or save it to disk. Select the method you would like to use. The file is .csv (comma separated variable) file that will open in a spreadsheet such as Excel.

6.32 Relay 8 Output Menu – Alarm Type

This page is used to set the alarm relay set points, etc.

You may also change the Relay Control Mode here. If you do, you will have to reselect the Input Assignment as well.

This section assumes that the Relay Control Mode is set to Counter Based Feed. Other control mode types are described in other sections of the manual.

Alarm Condition

In the left hand column, a list of all possible alarm conditions will be displayed. Only the alarm conditions that are possible given how your controller is configured will appear. To the right of each type of alarm condition there will be a column labeled Critical Alarm with a choice of “Yes” or “No”. Click on the “No” radio button if you do not want that type of alarm to be considered critical.

If an alarm condition is selected as a critical alarm, then you have the option of being notified that the alarm condition exists, by triggering the alarm relay, sending an email, or calling a pager. The WebMasterONE will attempt to send the alarm message email five times at 5 minute intervals and will then stop trying, even if unsuccessful.

Alarm Relay Status

This menu is for information only, and tells you if the alarm relay is currently on or off, and if it is on, for how much time. Possible status messages are Off, Off/Manual, On/Time counting up (indicating how long the alarm relay has been active) and On/Time counting down/Hand (for manual output activation).

Remote Alarm Action Status

This menu is for information only, and displays the status of the remote alarm notification. The possible messages to display are:

Alarm action completed:	The last alarm notification has already occurred and no further action is pending.
Found new alarm:	A new alarm has occurred and no notification has yet occurred.
Alarm due in HH:MM:SS	The alarm delay time will be displayed with time counting down.
Taking action:	The alarm notification is about to occur.
Sending email:	If notification is via email, this will be displayed.
Sending page:	If notification is via pager, this will be displayed.

Critical Alarm Action

Click on the check box to the left of the action or actions that you want to occur if a critical alarm condition exists. The controller can close or open the alarm relay, send an email or dial a pager, or any combination of the above.

Auto Dial Delay Time

In order to avoid being paged for an alarm condition that quickly corrects itself, you set a delay time for the alarm action. If the alarm condition still exists at the end of the delay time, then the alarm action will occur. If the alarm condition no longer exists at the end of the delay time, no notification will occur. Any value between 0 and 1440 minutes is acceptable.

Active When Relay Is

Click on the radio button that describes how you want the alarm relay to act. The normal method is to close the relay when an alarm condition exists, but you can also open the relay.

Output Mode

Click on the radio buttons to manually control the alarm relay. The normal selection will be *Auto*, where the controller uses the various set points to open and close the relay. You can force the relay open regardless of the presence of an alarm condition by selecting *Off*, or force the relay closed regardless of the presence of an alarm condition by selecting *Hand*.

If you select Off, the alarm relay will not be triggered again until either Hand or Auto is selected! If you select Hand, the relay will be closed until either Auto or Off is selected, or until the Hand Time Limit (programmed in the next menu) expires.

The Off mode is handy to use as an alarm silence. The Hand mode is handy to be able to test the relay, wiring, etc without needing to force an alarm condition.

Hand Time Limit

Type in the text box the maximum number of minutes that the alarm output can be activated in the Hand mode. Any value between 0 and 1440 is acceptable. A value of 0 means the output can be left on indefinitely.

Click on the “Submit” button to save the changes.

Log File

Click the link to View Log File. The Alarm Log will tell you the status of any alarm emails that may have been sent. It will show you the date and time of the alarm, the method of alarm notification, whether it was successful at sending the message or not, and the type of alarm.

A window will open to ask if you would like to open the file or save it to disc. Select the method you would like to use. The file is a basic text file with a .log extension that may be opened in any word processing program (Word, Notepad, etc.).

Relay Log

Click on the link to view the event log. The event log contains the date and time of each relay activation and deactivation. The data will be a ‘1’ if the relay is closed and a ‘0’ if the relay is open. The log also shows the state of the flow switch, with a ‘1’ denoting flow, and a ‘0’ denoting no flow.

A window will open to ask if you would like to open the file or save it to disk. Select the method you would like to use. The file is .csv (comma separated variable) file that will open in a spreadsheet such as Excel.

6.33 Analog Output (1-4) Menu *(only appears if one or more 4-20 mA output option cards are installed)*

4-20 mA Output Control Mode

Click on the pull-down to select between Not Used and Retransmit control mode.

Input Assignment

Click on the arrow to pull down the choices of which sensor measurement will be retransmitted as a 4-20 mA signal. The choices are any of the sensor inputs, any of the sensor’s temperature compensation inputs, LSI, RSI, any paddlewheel flow meter or any 4-20 mA input signal (only if the 4-20 mA input option is installed).

Input Status

This column shows the status of the sensor that has been mapped to the 4-20 mA output. Possible messages include Normal, Unmapped, and Sensor Error.

Input Reading

This column shows the process value of the input that is mapped to the 4-20 mA output. This will be in units of conductivity, pH, ORP, temperature or whatever the 4-20 mA input is using for units of measure.

Output mA Value

This column shows the status of the 4-20 mA output in mA.

Output Status

This column shows the status of the 4-20 mA output in %, as well as any error messages. It will read Normal if the input value is between the two programmed values defining the 4-20 mA output, or Over Range if the input is above the 20 mA value, or Under Range if it is below the 4 mA value.

Custom Name

Type the name you want to use to identify this output into the text box.

4 mA =

Type in the text box the input value that you want to correspond to a 4 mA output by the option card.

20 mA =

Type in the text box the input value that you want to correspond to a 20 mA output by the option card.

4-20 mA Loop Cal

If the device connected to the controller's 4-20 mA output is not reading correctly, click on the Set 4 mA button and the controller will output a fixed 4 mA signal. The receiving device can then be calibrated to read correctly for a 4 mA signal. Then click the Set 20 mA button and the controller will output a fixed 20 mA signal.

Click on the Submit button to save the changes.

6.34 LSI/RSI

This menu displays the calculated Ryznar's Stability Index and Langeliers Saturation Index and provides a place to enter the hardness and alkalinity wet test data used to calculate the indices.

RSI

The calculated value of the Ryznar's Stability Index is displayed here.

LSI

The calculated value of the Langeliers Saturation Index is displayed here.

Assign System Conductivity Input

Click on the arrow of the pull down menu to select the sensor input that is used for the System Conductivity (normally S1).

System Conductivity

The system conductivity reading from the selected conductivity sensor is displayed here.

System Temperature

The system temperature reading from the selected conductivity sensor is displayed here.

Calcium Hardness (CaCO₃)

The actual wet test data for calcium hardness in ppm should be typed in this text box.

Total Alkalinity (CaCO₃)

The actual wet test data for total alkalinity in ppm should be typed in this text box.

Assign pH Input

Click on the arrow of the pull down menu to select the sensor input that is used for the pH (normally S2).

pH

The pH reading from the selected sensor is displayed here.

6.35 Data Logging

Manual Data logging

You may either download data files automatically, or manually. To download automatically, click the Disable radio button, and set up the schedule in the Auto Reporting page (See Section 6.36). To download manually, click the Enable radio button, then go to the bottom of the page and click the Submit Datalog Details button.

Note that if you have an automatic data log building, and you click the Enable radio button to download data manually, the filtered set of data previously gathered will be lost!

You will now see additional menus, which allow you to set the start date and end date of the manual log, as well as the frequency of logging data points. Type the desired values in the text boxes. You will also get a button on the bottom of the page, Manual Download, which will initiate the downloading process of this file. You will be presented with the standard Windows dialog box, asking you what the file should be named and where you want the file to go.

Select the Measurements to Include in the Data Log File

You will be presented with a list of all of the parameters that can be logged, including sensor readings, totalizers, drum levels, and 4-20 mA inputs. The contents of the list will vary depending on what options you have installed or programmed. Click the “Yes” radio buttons of the parameters that you want to log, and the “No” radio buttons of the parameters that you do not want to log.

Click on the “Submit” button to save the changes.

To download the active data log, click the “Active Log Download” button and another window will open.. The WebMasterONE stores all parameters (used or not) every 20 minutes for 32 days, and this log contains everything. You will be presented with the standard Windows dialog box, asking you what the file should be named and where you want the file to go.

6.36 Auto Reporting

There are two types of reports that may be sent to you automatically. One is a system summary report, which will contain all of the information that is found on the System Summary page. This includes sensor readings and 4-20 mA inputs with a 24 hour minimum, maximum and average calculated, relay status, point level status, flow switch status, water meter totals, and alarms. This report may be sent by email.

The other type of automatic report is a data log report. This report will email a data log file of any parameters that you selected in the Data Logging page. This file may be opened in a spreadsheet for graphing or other data manipulation. This report may be sent on a cyclical schedule or over a specific date range.

System Status Reporting

Click the appropriate radio button to enable or disable the system status report feature.

Data Log Reporting

Click the appropriate radio button to enable or disable the data log report feature.

Log File

Click on the link called Log to manually download the Report log. This log details the date and time of the report, which type of report was sent, how the report was sent (email via modem or email via Ethernet), if the report was sent successfully or not, and if not, what the problem was. You will be presented with the standard Windows dialog box, asking if you want to open the file or save it. If it's to be saved, it asks what the file should be named and where you want the file to go.

System Status Reporting, Send Via

Click the appropriate radio button to select whether the report should be sent by email.

System Status Reporting, Status

This menu is informational only, telling you when the next report is due to be sent.

System Status Reporting, Reporting Mode

Click the appropriate radio button to select an Hourly, Daily, Weekly, Biweekly, or Monthly report frequency. Type the time of day for receiving the report in the text boxes, and use the pull down menus to select the desired day, and to select AM or PM.

Important: If this unit is part of a network of controllers, you must stagger the reports from each controller in the network to occur at least an hour apart. Failure to do this could result in lost reports!

Report Testing

Click the Test Reporting button to see if the report will be sent correctly. The email address entered in the Communications page will be used. If you haven't already entered this information, go the Communications page and do so before trying a test report.

Data Log Auto Reporting, Reporting Mode

Click the appropriate radio button to select either a Cyclical report schedule or a Calendar report schedule.

Data Log Auto Reporting, Logging Frequency

Type the frequency of the data points into the text box.

Data Log Auto Reporting, Log Duration

If you have selected a cyclical schedule, select a Daily, Weekly, Biweekly, or Monthly report frequency. Type the time of day for receiving the report in the text boxes, and use the pull down menus to select the desired day, and to select AM or PM.

If you have selected a calendar report, select the start date and time, and the end date and time.
Important: If this unit is part of a network of controllers, you must stagger the reports from each controller in the network to occur at least an hour apart. Failure to do this could result in lost reports!

6.37 Graphing/Trending

Recent data may be viewed in a graphic format on-line without downloading it to a computer first, and without opening it in a spreadsheet.

At the top of the page, a selection of boxes will be displayed. Check the box of the parameter that you would like to see graphed. The choices will be any direct sensor input and any 4-20mA input that is being used. Then select the Time Span of the data by selecting it from the pull-down. The choices are Last Hour, Day, 7 Days, 14 Days and 32 Days.

Click the Submit button for the changes to take effect.

The graphs selected will be presented below the check boxes on the web page. You may view details by moving your mouse over the portion of the graph that is of interest. The date, time and data of that coordinate will be displayed in the upper right hand corner of the graph.

The graph may be incorporated into a report document. Click on the "Export Graph" button. If you have a popup blocker installed, you will need to disable it. The graph will be converted to a jpg file and open in a new window. Click on File and Save as to save the image. You can also right-click the image, select copy, and then paste the image into your report.

6.38 Communications Menu

Internet Dial Up Account (only appears if a modem is installed)

Controller ISP User Name

When the controller needs to dial out and connect to the Internet Service Provider, it needs to identify itself with a user name, so that the ISP knows that it has an account. Type in the text box the user name that the controller will use.

Controller ISP Password

Similarly, the controller needs to identify itself with a password in order to connect with the ISP. Type in the text box the password that the controller will use. The password can also be changed here.

Primary ISP Phone No.

Type in the text box the first phone number for the controllers Internet Service Provider. This will be the phone number that it attempts to dial first.

Secondary ISP Phone No.

Type in the text box the second phone number for the controllers Internet Service Provider. This will be the phone number that it attempts to dial second, if the first number doesn't respond.

Controller Phone No

When you need to communicate with the controller, you go to the web site, link to the WebMasterONE access page, and a call is made from our server to the controller to wake it up. Type in the text box the phone number for the line to which the WebMasterONE is connected. Use the pull down menu to select the country where the controller is located.

Custom Country Code

If the country code required is not in the pull-down list, select (Other) Customer Country Code from the pull-down and then enter the country code in the text box.

Email**Email 1st Address**

When the WebMasterONE needs to send an email for notification of an alarm condition, or to send out a scheduled report, this is the first email address that it will use. Type in the text box the address to which you want the controller to send emails.

Email 2nd Address

If the emails need to be sent to more than one address, enter the second address in this text box.

Email 3rd Address

If the emails need to be sent to more than one address, enter the third address in this text box.

Email 4th address

If the emails need to be sent to more than one address, enter the fourth address in this text box.

Cell Phone Text Message

The email message above is in html format and will not be displayed correctly on a cell phone. The cell phone text message email will be truncated. Data log and summary reports are not sent to these addresses, only alarm emails.

1st Address – 4th Address

Type in the text box the addresses for a text message to be sent. Up to four addresses are available.

SMTP IP Address

In order for the controller to send an email, the email must first be routed to the SMTP IP address that the Internet Service Provider specifies. Obtain this address from your ISP and type it into the text box.

SMTP Port

If the SMTP server being used requires a different port than the standard port 25, enter that in the text box.

Controller email Address

The controller needs to be given an email address, which your ISP uses to identify the controller as having an account, so that the ISP will accept the email that the controller is sending, and route it to the intended recipient. Type in the text box the controller's email address.

Send Email Via

If you have both a modem card and an Ethernet card installed, click on the radio button of which you need to use to send an email notification of an alarm condition, or an automatic report.

Pager (only appears if a modem is installed)**Primary Pager No.**

If there is a pager that you want to be called in case of an alarm condition, type the telephone number in this text box.

Primary Pager PIN

Enter the primary pager's PIN number in this text box.

Secondary Pager No.

If there is another pager that should be used in an alarm condition, type the telephone number in this text box.

Secondary Pager PIN

Enter the PIN number for the secondary pager in this text box.

PIN Delay

Some pagers make you wait for a message to finish before prompting you to dial the PIN number. If the pager requires a pause before dialing the PIN number, type the number of seconds to wait between the answering service picking up and the PIN number being dialed. Any value between 1 and 60 seconds is acceptable.

Controller ID

When the controller calls a pager, it will leave a numeric message that is its phone number. You can have the controller dial some numbers attached to the end of the phone number to let you know that this is a controller calling and not some long-lost friend. Type in some code, for example *999, that will remind you that it is a controller calling.

Ethernet (LAN)**Network Mode**

If you have purchased the software to allow networking of controllers via Ethernet, use the pull down arrow to select the role that this controller will serve on the network. If it is not part of a network of WebMasterONE controllers, select "Independent". If it is the Master, select "Master". If it is the Slave, select "Slave". Once the network mode has been selected, the power to the controller must be cycled in order for the change to take effect.

Network Detection

Click on the Detect Network button of the Master Controller and it will look at all of the devices that are connected to it, determine which devices are its slaves, and refresh the Sub-Network frame in the lower left corner of your browser with all of the slaves detected.

Enable DHCP

Click on the radio button to enable DHCP if you want the controller to obtain its IP address from the local area network. This option only works if the controller is connected to a LAN.

Ethernet IP Address

When a controller is attached to a network, your IT Administrator needs to assign it an Ethernet IP address. When you want to communicate with the controller from your PC on the network, you go to your Browser and type in the controller's address. Type that address into the text box.

Ethernet IP Netmask

When a controller is attached to a network, your IT Administrator must also assign the IP Netmask. Type the number assigned in the text box.

Ethernet Gateway

When a controller is attached to a network, your IT Administrator must also assign the Gateway. Type the number assigned in the text box.

USB Connection**USB Connection IP Address**

In order to communicate with the controller via a laptop or nearby PC connected to the USB port on the front panel, you need to start your Browser software, and type in this address.

USB Connection Lifetime

If the USB connection has a problem, the controller will drop its end of the connection after 2 minutes. Under normal circumstances, the connection will stay alive indefinitely.

Direct Modem Connection (Point to Point)**Direct Modem IP Address**

This menu is information only and tells you the hard coded IP address for the controller when communicating to it via the direct modem to modem method.

ShoulderTAP[®] Internet Connection(only appears if a modem is installed)**Dialup Connection Status**

This menu is informational only, and tells you what is happening with the dialup connection. Possible status messages include:

<u>Message</u>	<u>Explanation</u>
▪ Off Line	The controller is not connected.
▪ Dialing xxx-xxxx	The controller is dialing out to the ISP.
▪ No Dial Tone	The controller can not dial out due to phone line or modem problems.
▪ No phone number	There is nothing entered in the ISP Phone No. field.
▪ Connecting to ISP	The controller is successfully negotiating a connection with the ISP.
▪ On Line	The controller is now on the Internet.
▪ Checking for Upgrade	The controller is communicating with our server to see if a software upgrade is available.
▪ Connection Timeout in xxxxx sec	Once the Internet connection process is complete. The number of seconds displayed depends upon the value entered in the Dialup Connection Lifetime text box described below.

Dialup Dynamic IP Address

This menu is informational only, and tells you the IP address of the last person to contact the controller.

Last Dialup Date and Time

This menu is informational only, and tells you when the controller was contacted last. Click on the “Submit” button to save the changes.

Dialup Connection Lifetime

This menu allows you to set a time limit on the Internet connection if no changes have been made. This will help control the cost of operating the controller if you forget to log off. Type in the text box the number of minutes that you want to pass by before disconnecting the Internet connection. Entering a connection lifetime of “0” means the connection will never timeout.

Manual Internet Dialup

Click on the Connect button to manually test the WebMasterONE’s ability to successfully dial out and connect with your ISP. This is convenient on installation, or to troubleshoot Internet connection problems. The Dialup Connection Status field will display what is happening as described above. Once you see that the Dialup Connection Status is “On-line”, you may disconnect the controller from the Internet by clicking the Disconnect button.

Modem Access Log

Click on the link to view the modem access log file. You will be prompted to either open the file (.csv format, normally opened in a spreadsheet) from its current location or to save the file to disk. Make your selection. The file will display the date and time of all modem connections, the type of connection (ShoulderTap or Direct Modem) if the attempt was a success or a failure, and if it failed, what the failure mode was.

6.39 Advanced Comms

Internet Dialup Account

Wait for dial tone before dialing

Click to place a check in the box if you want the modem to wait for a dial tone before calling out. In some countries the dial tone may not be recognized. If the modem will not recognize the dial tone, uncheck the box.

Modem Baud Rate

Click on the arrow of the pull-down to select different modem baud rates. The WebMaster modem is 38400. Normally there will be no reason to change the baud rate. The baud rate may be reduced if the process monitor is having problems at the higher speed due to poor phone line conditions. In the future, external modems may be supported that may not have the same baud rate.

Controller Telco Location

Click on the arrow of the pull-down to select the country where the process monitor is located.

Extra Modem Init String

For future use

USB WiFi Network Settings

For future use

Other Network Settings

Primary and Secondary DNS IP Address

These text boxes contain the address of a valid Domain Name Server, which allows the WebAlert to send the emails using the name of the email server rather than the numeric SMTP IP address.

The DNS IP addresses should never need to be changed, unless the server is experiencing problems.

Modbus Status

This field displays the activation status of the Modbus TCP feature.

Ethernet MAC Address

This field displays the MAC address of the Ethernet circuit, in case it is needed by the network IT administrator to identify the controller.

Use Java?

Check the box to use Java for viewing live data. The choice depends upon the browser you will use. Use Java should be checked if you are using Internet Explorer 5.0 or 6.0. You will need to have the Java Virtual Machine plug-in installed (available at www.java.com). If you are using Internet Explorer 7.0 or higher, or Mozilla Firefox, then Use Java should be unchecked.

Secure Tunnel Settings**For future use*****ASMTTP Settings*****ASMTTP User Name**

Type in the user name required for authenticated SMTP emails.

ASMTTP Password

Type in the password required for authenticated SMTP emails.

Use ASMTTP for email

Check the box if your Internet service provider requires authenticated SMTP for its emails.

Sub-Network Settings**Mapped Internet IP Address**

If you are accessing the master process monitor by using NAT to translate a real IP address to a fake IP address, then type the real IP address into this field of the master process monitor.

Direct Modem Connection (Point-to-Point)**Minimum required direct modem rings**

The modem will answer after 4-9 rings. The default value is 7. If this is a problem because the phone system will not allow that many rings, type the new number into the text box.

ShoulderTAP® Internet Connection

Dialup Connection Status

This menu is informational only, and tells you what is happening with the dialup connection.

Possible status messages include:

Message

- Off Line
- Dialing xxx-xxxx
- No Dial Tone
phone line
- No phone number

- Connecting to ISP

- On Line
- Checking for Upgrade

- Connection Timeout in xxxxx sec

Explanation

The process monitor is not connected.
The process monitor is dialing out to the ISP.
The process monitor can not dial out due to or modem problems.
There is nothing entered in the ISP Phone No. field.
The process monitor is successfully negotiating a connection with the ISP.
The process monitor is now on the Internet.
The process monitor is communicating with our server to see if a software upgrade is available.
Once the Internet connection process is complete. The number of seconds displayed depends upon the value entered in the Dialup Connection Lifetime text box described below.

Wireless Modem Antenna Setup

Antenna Setup

Before attempting to run the antenna setup, make sure that the dialup status is “Off Line.” Click the Start Setup button. It will prompt you to verify that you really want to start the setup. Click Yes and the setup will begin. Click on End Setup when you have finished. The dialup status should return to “Off Line.”

Signal Strength

This field will display the actual modem response string from the wireless modem.

Suggestion

This field will tell you whether the signal strength is Good, or if its Bad and you should try to relocate the antenna.

6.40 Configuration File Menu

If many of your applications are nearly identical, you can save a lot of time in the set up by downloading a typical configuration file to your hard drive, and later uploading the configuration file to another controller.

Export UCF

In order to transfer the User Configuration File (UCF) from the WebMasterONE to your computer, click the Export UCF link. You will be presented with the standard Windows dialog box to download a file. Click the radio button to Save this file to Disk, then click OK. Select the location where you want the file to be saved, change the name of the file if desired, then click Save. The file is only around 14KB, so it should be transferred relatively quickly. Click Close to close the dialog box.

The exact sequence of events and wording within the dialog box will vary depending upon the operating system (Windows 95, 98, NT, 2000, XP etc.) on your PC.

Browse

In order to transfer a previously saved UCF from your computer to this WebMasterONE, first click the Browse button to locate the file on your computer. A "Choose File" dialog box will open. Click on the correct file, then click Open.

Import UCF

Once the file name is displayed in the Browse text box, click the Import UCF button to transfer the file to the WebMasterONE.

6.41 Notepad

The configuration Notepad gives you a place to make notes regarding any changes that you have made to the set points, to document calibrations, system upsets or anything else that you want to note. Simply type your message into the text box.

6.42 Access Codes

There are three levels of access code protection. If the *Master* password is used in the WebMasterONE Authentication page, then any set point can be changed. If the *Calibration Level* password is used in the Authentication page, then sensor calibrations will be allowed, but other changes will not. If the *Read Only* password is used the user will be able to look at any page, but will not be allowed to make any changes.

In order to change the access code for each level of access, type the present password into the text box, then type the new password in the text box below. Type the new password again in the lowest text box to verify that the new password has been correctly entered.

The default user name is "webmaster" and the default passwords are "2001" for full access, "2002" for calibration only and "2003" for read only. These defaults can and should be changed to assure security.

Change User Log-in Name

You may also change the user name for logging into the WebMasterONE. Type the new user name into the text box.

Download Access Log

Click the link to View Log File. The Modem Access Log will tell you when the controller was accessed. It will show you the date and time of access, the method of access, the user name used, the IP address of the computer used for access, and the level of access code used (or that the attempt failed).

A window will open to ask if you would like to open the file or save it to disc. Select the method you would like to use. The file is a basic text file with a .log extension that may be opened in any word processing program (Word, Notepad, etc.)."

6.43 Software Upgrades (only appears if a newer revision of software is available)

Whenever you connect to the WebMasterONE via an Internet connection, it will check to see if any software upgrades are available. If there are, then the Software Upgrade page link will appear. Note that this can only occur if the controller is connected to the Internet, either through a modem or an Ethernet card.

If there is a newer version of software that you would like to load into your controller, then you can upgrade to the latest revision.

Click on the link “More Info on Software Upgrade” to see what features have been added.

Click on the link “Start Software Upgrade” in order to download the new version to the controller.

Note: Control is suspended during a software upgrade. If the controller being updated is a slave on a network of WebMasterONEs, both the master controller and the slave being updated will have control suspended during the upgrade process. Depending upon the extent of the changes and Internet traffic, the upgrade can take anywhere from 15 minutes to 2 hours to complete.

6.44 Sub-Network

Once you have created a network of two or more WebMasterONE controllers using Ethernet cards (see Figure 7 for wiring), purchased the Master Capability software for the master controller, defined the master unit as the master and slave units as slaves (see section 6.38) in the Communications page, and given each controller unique Ethernet IP addresses in the Communications page, then the links under Sub-Network will be active.

To navigate between controllers on the sub-network, start by logging onto the master controller. This may be via USB, Ethernet or modem. Once connected to the master, click on a link to the slave. The link will be given the custom name of the controller from the Startup page. The first time you connect to the slave in a given session, you will need to log on with that controller’s user name and password. After that, you will be able to bounce from one controller to another without logging on again.

If the links available do not accurately match the controllers on the network, go to the Communications page and click the ‘Detect Network ‘ button. If the sub-network frame is still inaccurate, right click in the frame and click ‘Refresh.’ If still inaccurate, try rebooting the controller.

7.0 MAINTENANCE

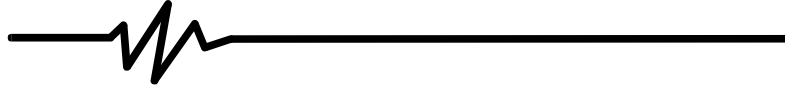

The WebMasterONE controller requires very little routine maintenance. The electronic enclosure only needs to be wiped down with a damp cloth to keep it clean. All other maintenance involves cleaning and calibrating sensors, described in detail below.



CAUTION! The WebMasterONE inner hinged face panel is secured with Phillips (#1) screws, which require a tool to open. No user adjustments are inside. This panel should only be opened by trained maintenance personnel.

7.1 Flow Switch Cleaning

The flow switch is designed to allow most particles to pass through, but it should occasionally be disassembled and cleaned. The frequency of cleaning required will vary with the cleanliness of the tower water. If the frequency of cleaning is excessive, and there are on-site personnel available, installation of a Y-strainer will reduce the time required for maintenance.

Refer to the exploded view drawing of the assembly on the following page.

To clean the flow switch, close the isolation valves to stop sample flow. Open the sample valve to relieve the pressure in the manifold. Remove the nut that holds the flow switch assembly in place. Pull the flow switch assembly straight up and out. The switch and the red float should come out together.

Clean the clear flow switch body with a bottle brush. Clean the switch/float assembly shaft with a cloth. If there is any build-up between the float and the switch shaft, remove the o-ring that retains the float on the shaft, and use a small bottle brush or compressed air to clean the inside of the float.

Reassemble all parts as shown in the exploded view diagram. Make sure that the sample valve is closed, open the isolation valves, and inspect for leaks.

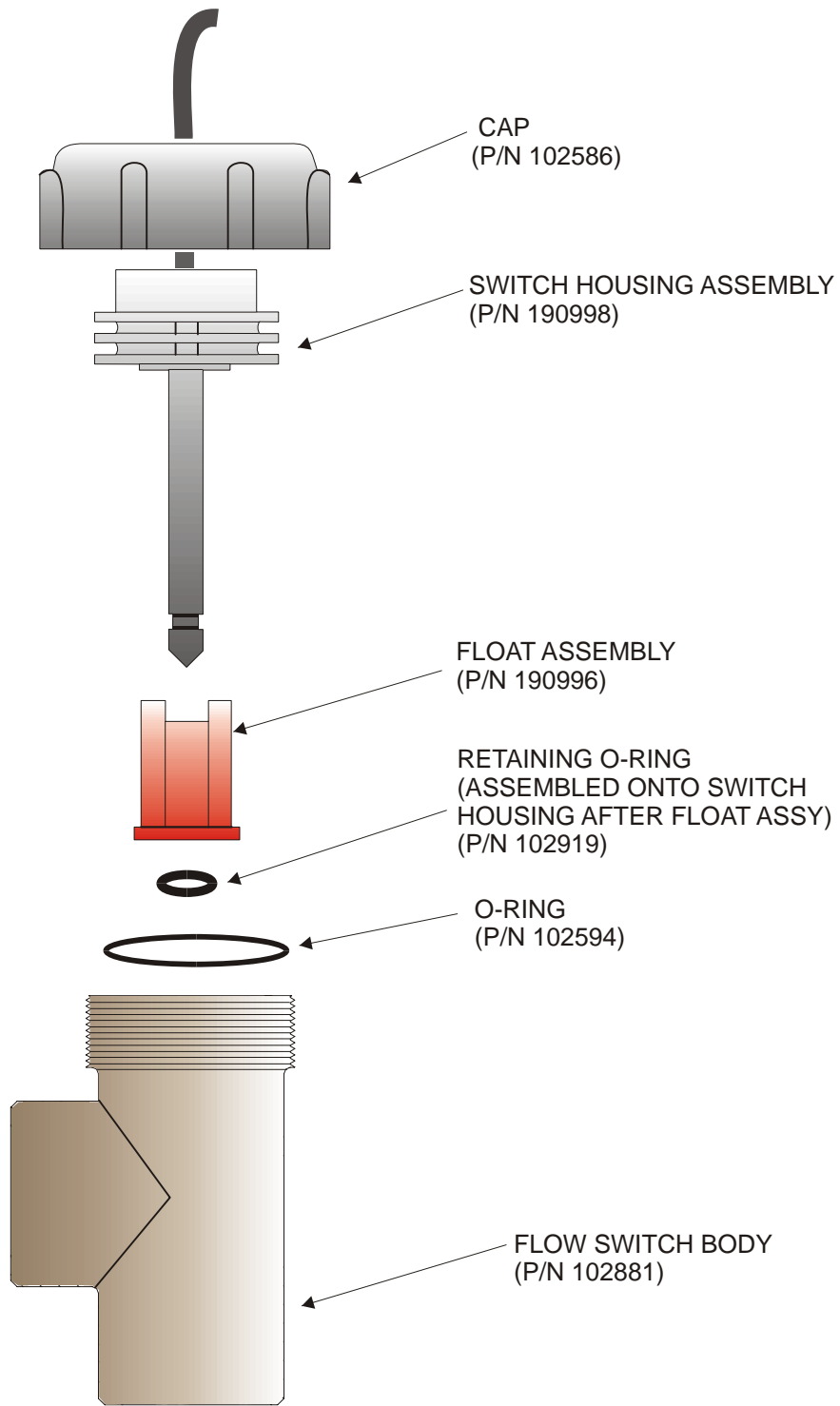

Figure 10 Flow Switch Assembly

7.2 Conductivity Sensor Cleaning and Calibration

Contacting Conductivity

The frequency of cleaning for the contacting conductivity electrode varies with each installation. The best way to determine the frequency is to compare the reading of the controller to the reading of a calibrated hand held instrument. When the two readings differ by an amount that you deem to be excessive (perhaps 5%), then it time to clean and recalibrate the electrode. The frequency should be every 2-3 months or so.

To clean the contacting conductivity electrode, close the isolation valves to stop sample flow. Open the sample valve to relieve the pressure in the manifold. Remove the nut that holds the electrode in place. Pull the electrode straight up and out.

For loose coatings, wipe with a cloth. Avoid smearing graphite from one electrode to the other. For removal of scale, dip in a dilute hydrochloric or gallic acid solution, and rinse. For oils (including fingerprints!) wash with a detergent.

Reassemble all parts. Note that the conductivity electrode is keyed to only reinsert in one orientation. Make sure that the sample valve is closed, open the isolation valves, and inspect for leaks.

After cleaning, it is necessary to recalibrate the electrode. This is only accurate when the electrode is installed in the piping.

High Temperature Contacting Conductivity

The frequency of cleaning for the contacting conductivity electrode varies with each installation. The best way to determine the frequency is to compare the reading of the controller to the reading of a calibrated hand held instrument. When the two readings differ by an amount that you deem to be excessive (perhaps 5%), then it time to clean and recalibrate the electrode. The frequency should be every 2-3 months or so.

To clean the high temperature contacting conductivity electrode, close the isolation valve(s) to stop sample flow. Open the manual blowdown bypass valve to relieve the pressure in the piping. Remove the electrode from the pipe.

For removal of scale, dip in a dilute hydrochloric or gallic acid solution, and rinse. For oils (including fingerprints!) wash with a detergent.

Replace the electrode in the pipe. Note that the sensor should be placed with the hole facing the direction of flow. Open the isolation valves and inspect for leaks.

After cleaning, it is necessary to recalibrate the electrode. This is only accurate when the electrode is installed in the piping.

Electrodeless Conductivity

The frequency of cleaning for the electrodeless conductivity electrode varies with each installation. The best way to determine the frequency is to compare the reading of the controller to the reading of a calibrated hand held instrument. When the two readings differ by an amount that you deem to be excessive (perhaps 5%), then it time to clean and recalibrate the electrode. The frequency should be every 6 months or so.

To clean the electrodeless conductivity sensor, close the isolation valves to stop sample flow. Open the sample valve to relieve the pressure in the manifold. Remove the nut that holds the sensor in place. Pull the sensor straight up and out.

For loose coatings, wipe with a cloth. Use a bottle brush to clean out the internal channels. For removal of scale, dip in a dilute hydrochloric or gallic acid solution, and rinse. The electrodeless sensor is immune to oily coatings.

Reassemble all parts. Make sure that the sample valve is closed, open the isolation valves, and inspect for leaks.

After cleaning, it is necessary to recalibrate the electrode. This is only accurate when the electrode is installed in the piping.

7.3 pH Electrode Cleaning and Calibration

The frequency of cleaning for the pH electrode varies with each installation. The best way to determine the frequency is to compare the reading of the controller to the reading of a calibrated hand held instrument. When the two readings differ by an amount that you deem to be excessive (perhaps 0.5 pH units), then it time to clean and recalibrate the electrode. This should be every 2-3 months.

To clean the pH electrode, close the isolation valves to stop sample flow. Open the sample valve to relieve the pressure in the manifold. Remove the nut that holds the electrode in place. Pull the electrode straight up and out.

For loose coatings, wipe with a cloth. Avoid rough handling of the pH sensitive glass. For removal of scale, dip in a dilute hydrochloric or gallic acid solution, and rinse. For oils (including fingerprints!) wash with a detergent or isopropyl alcohol.

Reassemble all parts. Make sure that the sample valve is closed, open the isolation valves, and inspect for leaks.

After cleaning, it is necessary to recalibrate the electrode. Refer to Section 6.5 for detailed calibration instructions.

7.4 ORP Electrode Cleaning and Calibration

The frequency of cleaning for the ORP electrode varies with each installation. The best way to determine the frequency is to verify that the desired oxidizer concentration is within your required limits when the controller indicates that the ORP is at the set point value. The frequency of cleaning should be every 2-3 months or so.

To clean the ORP electrode, close the isolation valves to stop sample flow. Open the sample valve to relieve the pressure in the manifold. Remove the nut that holds the electrode in place. Pull the electrode straight up and out.

For loose coatings, wipe the platinum tip with a cloth. For removal of scale, dip in a dilute hydrochloric or sulfuric acid solution, and rinse. For oils (including fingerprints!) wash with a detergent or isopropyl alcohol. For very stubborn coatings, jeweler's rouge may be used to polish the platinum tip.

Reassemble all parts. Make sure that the sample valve is closed, open the isolation valves, and inspect for leaks.

After cleaning, it is necessary to recalibrate the electrode. Refer to Section 6.6 for detailed calibration instructions.

7.5 Replacing the Fuses

CAUTION: Disconnect power to the controller before opening the front panel!

Locate the fuses on the relay interface board on the lower left side of the back of the controller enclosure. See figure 5, Identification of Parts. Gently remove the old fuse from its retaining clip. You can verify that the fuse has been blown by measuring continuity between the ends of the fuse using an ohmmeter. If it is blown, discard. Press the new fuse into the clip, secure the front panel of the controller, and return power to the unit.

Warning! Use of non-approved fuses can affect product safety approvals. Specifications are shown below. To ensure that UL/CSA product safety certifications are maintained, it is recommended that a factory original fuse be used.

Fuse		P/N			
F1	Protects Power Input	102833	5 x 20 mm	1.6 amp	250 V
F3	Protects R1, R2, R3 and R4 relay outputs	102834	5 x 20 mm	6.3 amp	250 V
F2	Protects R5, R6, R7, and R8 relay outputs	102834	5 x 20 mm	6.3 amp	250 V

8.0 TROUBLESHOOTING

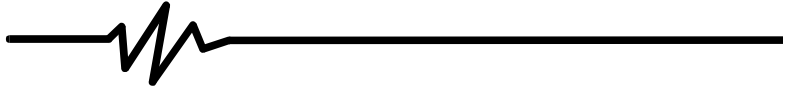

8.1 ERROR MESSAGES

Conductivity Calibration Failure

This error message occurs after calibration of the conductivity sensor. A clean sensor should give a predictable signal in a solution of known conductivity. If the calibration adjusts the signal more than 50% away from the predicted value, the calibration will fail. A signal this far off indicates a problem with the reading, and is not normal.

Possible Causes

Dirty sensor.

Incorrect sensor cable used.

Sensor cable disconnected.

Sensor cable connected incorrectly

Problem with hand-held instrument

Faulty sensor.

Faulty core interface circuit board
(if Sensor 1).

Faulty sensor option circuit board
(if Sensors 2-4).

In Boilers, Flashing

If Intermittent Sampling, faulty valve

Corrective Actions

Clean sensor as described in Section 6.2 above.

Refer to Installation Guidelines in Section 3.3.

Reconnect cable.

Check connections of all 6 wires against Fig 5

Refer to the troubleshooting guide for the hand held instrument used to determine the system conductivity.

Replace sensor.

Replace the core interface board.

Replace the sensor option board.

Refer to Installation Guidelines in Section 3.3

Check all upstream and downstream valves to ensure that a sample is reaching the sensor.

pH Calibration Failure

This error message occurs after attempting an electrode calibration. The normal slope of a pH electrode is 59 mV/pH unit. As the electrode ages, this slope will decrease. The WebMasterONE reports the % difference from the theoretical slope after each calibration. When the slope reaches 12 mV/pH unit (80% difference), the calibration fails.

Possible Causes

Dirty electrode.

Faulty electrode cartridge.

Sensor cable disconnected.

Faulty electrode housing.

Faulty core interface circuit board
(if Sensor 1).

Faulty sensor option circuit board
(if Sensors 2-4).

Corrective Actions

Clean electrode and recalibrate as described in Section 7.3 above.

Replace cartridge.

Reconnect cable. Also ensure that the electrode cartridge is tightly screwed into the electrode housing, and that the inside of the housing is dry. Make sure that the +/- 5 VDC and the IN-, IN+ wires are firmly attached.

If the controller passes self test, the wiring is correct, the +/- 5 VDC signal is present and the cartridge is attached and OK, replace the electrode housing.

Replace the core interface board.

Replace the sensor option board.

ORP Calibration Failure

This error message occurs after calibrating the ORP electrode. If the difference between the raw mV reading and the calibrated value exceeds 50%, then the calibration will fail.

Possible Causes

Dirty electrode.

Faulty electrode cartridge.

Sensor cable disconnected.

Faulty electrode housing.

Faulty core interface circuit board
(if Sensor 1).

Faulty sensor option circuit board
(if Sensors 2-4).

Corrective Actions

Clean electrode and recalibrate as described in Section 7.4 above.

Replace electrode cartridge.

Reconnect cable. Also ensure that the electrode cartridge is tightly screwed into the electrode housing, and that the inside of the housing is dry. Make sure that the +/- 5 VDC and the IN-, IN+ wires are firmly attached.

If the controller passes self test, the wiring is correct, the +/- 5 VDC signal is present and the cartridge is attached and OK, replace electrode housing.

Replace the core interface board.

Replace the sensor option board.

Output Time Out

This error message indicates that the relay output has been activated for an amount of time that exceeds the user-programmed maximum allowable time. The output relay will be forced off until the “Reset Timeout” button found in that Relay Output Page is clicked.

Possible Causes

Maximum time is set too low for normal circumstances

Process value was higher/lower than normal.

Control direction is set incorrectly.

Faulty control device attached to relay.

Relay is interlocked when it should not.

Fuse blown.

Faulty wiring of control device.

Faulty relay.

You are feeding based on flow meter volume, and you are getting false contacts.

Faulty Sensor.

Chemical supply is empty.

Corrective Actions

Go to the Relay Output Page and increase the programmed value for the maximum time.

Go to the Relay Output Page and increase the programmed value for the maximum time until the process value is brought back down to normal levels.

Go to the Relay Output Page and check the setting for the control direction.

Repair or replace control device.

Evaluate switch for Interlock.

Replace fuse (F2 or F3).

Correct wiring.

Replace the relay interface board.

Go to the Flow Meter Input Page and verify that the flow total is increasing even when the solution is not flowing.

Disconnect the flow meter cable from the controller and verify that the flow total stops increasing. Route the flow meter cable away from any AC voltage and make sure that the cable is shielded.

Clean and calibrate the electrode as described in Section 7 above. If the calibration fails, see troubleshooting for sensor calibration failure.

Refill chemical supply.

Conductivity High Alarm

This error message indicates the conductivity reading exceeds the user-programmed maximum allowable value.

Possible Causes

Programmed value is too close to conductivity set point.

Control direction is set incorrectly.

Faulty control device.

Fuse blown.

Faulty control device wiring.

Faulty relay.

Corrective Actions

Go to the Conductivity Input Page and make sure that the high alarm limit is set at least 5% above the set point.

Go to the Relay Output Page and check the setting for the control direction.

Repair or replace the control device.

Replace fuse (F2 or F3).

Correct wiring.

Replace the relay interface board.

Conductivity Low Alarm

This error message indicates the conductivity reading is below the user-programmed minimum allowable value.

Possible Causes

Dirty conductivity electrode.

Faulty conductivity electrode wiring.

Faulty conductivity electrode.

Conductivity electrode is dry.

No sample flow.

Faulty control device.

Fuse blown.

Faulty control device wiring.

Faulty relay.

Intermittent Sampling, sampling too frequently

Corrective Actions

Clean and calibrate the conductivity sensor as described in Section 7.2 above. If calibration fails, see troubleshooting for Conductivity Calibration Failure above.

Correct wiring.

Replace sensor.

Adjust sensor location below the minimum water level.

Restore flow of sample

Repair or replace the control device (valve).

Replace fuse (F2 or F3).

Correct wiring.

Replace the relay interface board.

Increase the Interval Time.

pH High Alarm

This error message indicates the pH reading exceeds the user-programmed maximum allowable value.

Possible Causes

The programmed value is too close to pH set point.

Chemical supply empty.

Faulty pH electrode.

Control direction set incorrectly.

Control device set at too high a flow rate.

Metering pump is siphoning.

Faulty control device.

Blown fuse.

Faulty control device wiring.

Faulty pH output relay.

The pH dead band is set too high.

Corrective Actions

Go to the pH Input Page and make sure that the the High Alarm Limit is set at least 0.5 pH units above the set point.

Replenish chemical supply.

Clean and calibrate the electrode as described in Section 7.3 above. If the calibration fails, see troubleshooting for pH Calibration Failure above.

For acid feed the control direction should be “force lower” for caustic feed, “force higher”. Go to the Relay Output Page and verify the correct setting.

Reduce the flow rate of the control device.

Install or repair the anti-siphon valve.

Repair or replace the control device.

Replace the fuse (F2 or F3).

Correct the control device wiring.

Replace the relay interface board.

Go to the pH Output Page and change the dead band to be as low as possible to prevent the pH relay from chattering. If the pH reading fluctuates by +/- 0.02 pH units, then a dead band of 0.05 is sufficient.

pH Low Alarm

This error message indicates the pH reading is below the user-programmed minimum allowable value.

Possible Causes

The programmed value is too close to pH set point.

Chemical supply empty.

Faulty pH electrode.

Control direction set incorrectly.

Control device set at too high a flow rate.

Metering pump is siphoning.

Faulty control device.

Blown fuse.

Faulty control device wiring.

Faulty pH output relay.

The pH dead band is set too high.

Corrective Actions

Go to the pH input page and make sure that the the Low Alarm Limit is set for at least 0.5 pH units below the set point minus the dead band.

Replenish chemical supply.

Clean and calibrate the electrode as described in Section 7.3 above. If the calibration fails, see troubleshooting for pH Calibration Failure above.

For acid feed the control direction should be “force lower” for caustic feed, “force higher”. Go to the Relay Output Page and verify the correct setting.

Reduce the flow rate of the control device.

Install or repair the anti-siphon valve.

Repair or replace the control device.

Replace the fuse (F2 or F3).

Correct the control device wiring.

Replace the relay interface board.

Go to the pH Output Page and change the dead band to be as low as possible to prevent the pH relay from chattering. If the pH reading fluctuates by +/- 0.02 pH units, then a dead band of 0.05 is sufficient.

ORP High Alarm

This error message indicates the ORP reading exceeds the user-programmed maximum allowable value.

Possible Causes

The programmed value is too close to the ORP set point.

Slow ORP electrode response, dirty electrode.

Control direction set incorrectly.

Control device set at too high a flow rate.

Chemical supply empty.

Metering pump is siphoning.

If a brominator, solenoid valve is stuck open.

The ORP dead band is set too high.

Faulty control device wiring.

ORP output relay is stuck closed.

Blown fuse.

Corrective Actions

Go to the ORP Input Page and make sure that the High Alarm Limit is more than 50 mV above the set point plus the dead band.

Clean and calibrate the ORP electrode as described in Section 7.4 above. If the calibration fails, refer to the ORP Calibration Failure troubleshooting above.

For oxidizer feed the control direction should be “force higher”, for reducer “force lower”. Go to the ORP Output Page and make sure that the correct control direction is selected.

Reduce the flow rate of the control device.

Replenish chemical supply.

Repair or install an anti-siphon valve.

Repair or replace the solenoid valve.

Go to the ORP Output Page and change the dead band to be as low as possible to prevent the ORP relay from chattering. If the ORP reading fluctuates by +/- 2 mVs, then a dead band of 5 mV is sufficient.

Correct wiring.

Replace the relay board.

Replace fuse (F2 or F3).

ORP Low Alarm

This error message indicates the ORP reading is below the user-programmed maximum allowable value.

Possible Causes

The programmed value is too close to the ORP set point.

Chemical supply empty.

Faulty ORP electrode.

Control direction set incorrectly.

Faulty metering pump/brominator solenoid valve.

Metering pump is siphoning.

Blown fuse.

Faulty control device wiring.

Faulty ORP output relay.

Corrective Actions

Go to the ORP Input Page and make sure that the Low Alarm Limit is at least 50 mV below the set point.

Replenish chemical supply.

Clean and calibrate the ORP electrode as described in Section 7.4 above. If the calibration fails, refer to ORP Calibration Failure troubleshooting above.

For oxidizer feed the control direction should be “force higher”, for reducer “force lower”. Go to the ORP Output Page and make sure that the correct control direction is selected.

Repair or replace the metering pump/solenoid valve.

Repair or install an anti-siphon valve.

Replace fuse (F2 or F3).

Correct wiring.

Replace the relay board.

Drum Level Low Alarm (one for each used)

This error message appears if either a level switch or level transmitter is putting out a signal that indicates a low level of solution. This could mean that the level switch is either open or closed, or that the level transmitter is indicating a volume below the user-programmed low alarm limit.

Possible Causes

Low chemical level.

Level switch float is stuck.

Faulty level switch.

Incorrect setting of the low alarm limit for the level transmitter.

Corrective Actions

Replenish chemical supply.

Clean level switch.

Remove level switch from drum and verify that the switch opens and closes as the float is moved up and down.

Go to the Level Input Page and make sure that the Low Alarm Limit is set for the correct value.

Faulty level switch or transmitter wiring.	Correct wiring. Make sure that the level sensor is attached to the same input as the one which is defined for that drum in the Level Input Page.
Incorrect setting of “Drum low when switch is open/closed” menu.	Go to the “Level Input Page and verify that the “Drum low when switch is” menu is set for the proper selection. You can check the operation of the switch by measuring between the two wires with an ohmmeter. If there is continuity between the wires when the float is all the way down, the select “closed”.
Incorrect setting of the “Empty mA” menu.	Go to the Level Input Page and make sure that the Empty mA setting matches the actual mA of the transmitter when the tank is empty.
Faulty digital input circuit board.	If the switch is functioning, and it is wired correctly, and the settings are correct, replace the digital input board.
Faulty 4-20 mA input option circuit board.	If the level transmitter is putting out a mA signal above the low alarm limit (as measured by an ammeter) and is wired correctly, replace the 4-20 mA input option board.

Pump Failure (one for each monitored)

This error message appears if contact closures from the PosiFlow flow monitor are expected but are not detected by the digital input option circuit board.

Possible Causes

Corrective Actions

Metering pump has lost prime.	Re-prime metering pump.
Faulty metering pump.	Repair or replace metering pump.
Faulty metering pump wiring.	Correct wiring.
Faulty PosiFlow wiring.	Correct wiring. Make sure that digital input the PosiFlow is connected to is defined as the expected pump PosiFlow input in the PosiFlow Page.
Faulty PosiFlow sensor.	Replace PosiFlow sensor.
Blown fuse.	Replace fuse (F2 or F3)
Faulty output relay.	Replace relay board.
Faulty digital input circuit board.	Verify that PosiFlow is making contact closures using an ohmmeter. If OK, and connected properly, replace digital input board.

4-20 mA Input High Alarm

This error message is caused by the 4-20 mA signal exceeding the user-programmed value for the high alarm limit.

Possible Causes

The process value being measured by the transmitter is out of specifications

.

The high alarm limit for the process being measured is set too low.

There is a problem with the transmitter that needs to be addressed by the manufacturer of the transmitter.

Corrective Actions

Determine the reason for the out of spec condition.

Increase the high limit in the 4-20 mA Input Page.

4-20 mA Input Low Alarm

This error message is caused by the 4-20 mA signal being lower than the user-programmed value for the low alarm limit.

Possible Causes

The process value being measured by the transmitter is out of specifications.

The low alarm limit for the process being measured is set too high.

There is a problem with the transmitter that needs to be addressed by the manufacturer of the transmitter.

Corrective Actions

Determine the reason for the out of spec condition.

Decrease the low limit in the 4-20 mA Input Page.

Conductivity Sensor Error

This error message is caused by the signal from the conductivity sensor being outside of the normal range (input voltage outside -1.45 VDC to $+1.45$ VDC or a conductivity reading above the full scale maximum). Any relay controlled by the sensor will be forced off. .

Possible Causes

The conductivity is extremely high (over full scale).

Faulty core interface or sensor option circuit board.

Faulty conductivity sensor wiring.

Faulty conductivity sensor.

Corrective Actions

Go to the Conductivity Input Page and check the uncalibrated conductivity reading. Compare this to a calibrated hand held instrument.

Go to the Conductivity Input Page and perform a self test. If this passes, then the problem is with the sensor or its wiring. If it fails, then disconnect the sensor from the circuit board and repeat the self test. If it still fails, replace the circuit board.

Make sure that the sensor cable is connected (if system conductivity) properly, and there are no shorts in any extension cables. Also make sure that the sensor cable is not routed near any AC voltage wiring. Make sure that the cable is properly shielded.

Replace sensor.

pH Sensor Error

This error message is caused by the signal from the pH electrode being outside of the normal range (pH less than -2 or greater than 16 , or input voltage outside -1.45 VDC to $+1.45$ VDC). Any relay being controlled by the sensor will be forced off.

Possible Causes

Faulty pH cartridge.

Faulty pH electrode wiring.

Faulty preamplifier housing.

Faulty sensor input circuit board.

Corrective Actions

Replace cartridge.

Make sure that the electrode cartridge is firmly screwed into the housing. Make sure that there is no water inside the housing. Make sure that the ± 5 VDC and the IN-, IN+ wires are firmly attached. Also make sure that the sensor cable is not routed near any AC voltage wiring. Make sure that the cable is properly shielded.

If the controller passes self test, the wiring is correct, the ± 5 VDC signal is present and the cartridge is attached and OK, replace the housing.

Go to the pH Input Menu and perform a self test. If it fails, remove the electrode wires from the pH input board and try the self test again. If it passes, the problem is in the electrode, housing or its wiring. If it still fails, replace the pH input board.

ORP Sensor Error

This error message is caused by the signal from the ORP electrode being outside of the normal range (-1450 to 1450 mV). Any relay being controlled by the sensor will be forced off.

Possible Causes

Faulty ORP cartridge.

Faulty ORP electrode wiring.

Faulty preamplifier housing.

Faulty sensor input circuit board.

Corrective Actions

Replace cartridge.

Make sure that the electrode cartridge is firmly screwed into the housing. Make sure that there is no water inside the housing. Make sure that the +/- 5 VDC and the IN-, IN+ wires are firmly attached. Also make sure that the sensor cable is not routed near any AC voltage wiring. Make sure that the cable is properly shielded.

If the controller passes self test, the wiring is correct, the +/- 5 VDC signal is present and the cartridge is attached and OK, replace the housing.

Go to the ORP Input Menu and perform a self test. If it fails, remove the electrode wires from the ORP input board and try the self test again. If it passes, the problem is in the electrode, housing or its wiring. If it still fails, replace the ORP input board.

Temperature Sensor Error

This error message is caused by the temperature signal being outside the normal range (around 1500-33,000 ohms for contacting conductivity sensors, 15,000 to 330,000 for electrodeless conductivity sensors, 1000 to 1400 ohms for pH sensors and high temperature conductivity sensors). Any relay controlled by the faulty sensor will be forced off.

Possible Causes

Faulty temperature sensor wiring

Faulty conductivity sensor.

Corrective Actions

Measure the temperature signal using an ohmmeter between the green wire and the green/white wire as close to the sensor as possible, with the wires disconnected from the terminal strip. This should be around 8,000 ohms at 85 F, 30 C for a contacting electrode, 80,000 ohms for an electrodeless sensor, and 1115 ohms for a pH or high temp sensor. If OK, check this again at the terminal strip of the circuit board. If OK, make sure that the wires are connected firmly to the correct terminals.

If you measure resistance outside the acceptable range directly from the sensor, replace the sensor.

Faulty sensor input board

Go to the Conductivity Input Page and perform a self test. If this passes, then the problem is with the sensor or its wiring. If it fails, then disconnect the sensor from the circuit board and try the self test again. If it still fails, replace the circuit board.

Total Alarm Limit

The totalizer for a flow meter input or counter input has exceeded its programmed maximum limit.

Possible Causes

The system has experienced too high a total

You are getting false contacts.

Corrective Actions

Evaluate system

Go to the appropriate Input Page and verify that the total is increasing even when the solution is not flowing.

Disconnect the input's cable from the controller and verify that the total stops increasing. Route the input's cable away from any AC voltage and make sure that the cable is shielded.

Rate High Alarm

The rate for a flow meter input or counter input has exceeded its programmed maximum limit.

Possible Causes

The system has experienced too high a rate

The rate high alarm point is too low

You are getting false contacts.

Corrective Actions

Evaluate system

Go to the input page and reset the limit

Go to the appropriate Input Page and verify that the total is increasing even when the solution is not flowing.

Disconnect the input cable from the controller and verify that the flow total stops increasing. Route the input cable away from any AC voltage and make sure that the cable is shielded.

Rate Low Alarm

The rate for a flow meter input or counter input is less than its programmed minimum limit.

Possible Causes

The system has experienced too high a rate

The rate low alarm limit is too high

The input is no longer connected

Faulty device

Faulty digital input

Corrective Actions

Evaluate system

Go to the input page and reset the alarm limit

Check the wiring. Short the cable at the device end to verify that it is OK.

Repair or replace the device.

If shorting the input does not yield a count, replace the input circuit board.

Sensor calibration time

Normal condition; programmed calibration reminder time has elapsed

4-20 mA Input Sensor Error

This error message is caused by a 4-20 mA input signal that is less than 3.9 mA or greater than 21 mA.

Possible Causes

Faulty transmitter.

Faulty wiring between transmitter and analog input option circuit board.

Faulty analog input option circuit board.

Corrective Actions

Make sure that the transmitter is functioning by measuring the output using an ammeter. If the output directly from the transmitter is less than 4 mA, the transmitter is the problem.

Repeat the measurement of the transmitter output at the 4-20 mA input option board terminal strip. If this is less than 4 mA, then the wiring is faulty. Also make sure that the wires are attached to the correct terminals as defined in the 4-20 mA Input Page.

Replace the 4-20 mA input option board.

Sensor Board Failure

This error message is caused by a failure of the controller to recognize that the option circuit board is connected. The ORP output relay will be forced off.

Possible Causes

Poor connection of the option board to the sensor interface board.

Faulty sensor input board.

Corrective Actions

Remove the option board and inspect both mating connectors for corrosion or damage. Reinstall the option board.

Replace the sensor input board.

4-20 mA Input Board Failure

This error message is caused by a failure of the controller to recognize that the option circuit board is connected. If using a 4-20 mA type water meter, then bleed/feed output will be forced off.

Possible Causes

Poor connection of the option board to the relay interface board.

Faulty 4-20 mA input board.

Corrective Actions

Remove the option board and inspect both mating connectors for corrosion or damage. Reinstall the option board.

Replace the board.

Digital Input Board Failure

This error message is caused by a failure of the controller to recognize that the option circuit board is connected. If utilizing the Interlock feature, then any outputs that are set to deactivate in case of an Interlock condition will be forced off.

Possible Causes

Poor connection of the option board to relay interface board.

Faulty digital input board.

Corrective Actions

Remove the option board and inspect both the mating connectors for corrosion or damage. Reinstall the option board.

Replace the board.

Modem Failure

This error message is caused by a failure of the controller to recognize that the option circuit board is connected.

Possible Causes

Poor connection of the option board to the core board.

Faulty modem board.

Corrective Actions

Remove the option board and inspect both mating connectors for corrosion or damage. Reinstall the option board.

Replace the board.

Ethernet Card Failure

This error message is caused by a failure of the controller to recognize that the option circuit board is connected.

Possible Causes

Poor connection of the option board to the core board.

Faulty Ethernet board.

Corrective Actions

Remove the option board and inspect both mating connectors for corrosion or damage. Reinstall the option board.

Replace the board.

Temperature High Alarm

This error message is caused by the temperature signal from the conductivity sensor exceeding the user-programmed value for the high alarm limit.

Possible Causes

The actual temperature is too high.

The programmed value is set too close to the normal operating temperature.

The temperature sensor has lost calibration.

Faulty circuit board.

Faulty temperature sensor.

Corrective Actions

Correct problem with process.

Go to the sensor input page and increase the high alarm limit.

Go to the Temperature Input Page and calibrate the temperature.

Go to the Temperature Input Page and perform a self test. If the self test fails, then the sensor input board (if makeup) or the core interface board (if system) should be replaced.

If a successful calibration is not possible, the temperature sensor is probably faulty, and the sensor should be replaced.

Temperature Low Alarm

This error message is caused by the temperature signal from a sensor being below the user-programmed value for the low alarm limit.

Possible Causes

The actual temperature is too low.

The programmed value is set too close to the normal operating temperature.

The temperature sensor has lost calibration.

Faulty circuit board.

Faulty temperature sensor.

Poor connection of temperature wires.

Corrective Actions

Correct problem with process.

Go to the sensor input page and decrease the low alarm limit.

Go to the sensor input page and calibrate the temperature.

Go to the sensor input page and perform a self test. If the self test fails, then the sensor input board (if sensors 2-4) or the core interface board (if sensor 1) should be replaced.

If a successful calibration is not possible, the temperature sensor is probably faulty, and the sensor should be replaced.

Excessive resistance from extension cables or poor connections can lower the temperature reading. Clean & tighten all connections to the temperature sensor.

8.2 PROBLEMS THAT DON'T GENERATE AN ERROR MESSAGE

Submit buttons do not appear on any page

You have logged in using a Calibration level or Read Only level password. Only the Master level password allows changes to be made.

Sensor Input menu links missing

The controller not detecting the sensor input option board at power up causes this problem.

Possible Causes

No sensor input board is installed

Loose option board connection.

Faulty sensor input board.

Corrective Actions

Install a sensor input board.

Remove power to the unit.
Push board onto pins and turn power on.

This should cause a "Sensor Board Failure" error message, but this can be cleared once the power is cycled. Replace the sensor input board.

Temperature calibration, high/low alarm menus missing from Sensor Input page

The controller not detecting the temperature sensor at power up causes this problem.

Possible Causes

The temperature sensor is not connected.

Faulty temperature sensor.

Sensor input is selected to be an ORP type

Corrective Actions

Connect the temperature sensor and turn power on.

Measure the temperature signal using an ohmmeter between the green wire and the WHT/GRN wire as close to the sensor as possible with the wires disconnected from the terminal strip. If the reading is infinite ohms, replace the sensor.

This is normal. ORP inputs do not use automatic temperature compensation.

Link to 4-20 mA Output page does not appear

The controller not detecting any 4-20 mA output boards at power up causes this problem.

Possible Causes

No 4-20 mA output boards are installed.

Poor connection of the 4-20 mA output board.

Corrective Actions

Install one or more 4-20 mA output boards and turn power on.

Remove the option board and inspect both mating connectors for corrosion or damage
Reinstall the option board on turn power on.

Link to Level page does not appear

The controller not detecting either a digital input board or an analog input board at power up causes this problem.

Possible Causes

No digital or analog input board is installed.

Poor connection of the option board.

Corrective Actions

Install the desired option board and turn power on.

Remove the option board and inspect both mating connectors for corrosion or damage
Reinstall the option board on turn power on.

Link to Digital Inputs page does not appear

The controller not detecting a digital input board at power up causes this problem.

Possible Causes

No digital input board is installed.

Poor connection of the option board.

Corrective Actions

Install the digital input option board and turn power on.

Remove the option board and inspect both mating connectors for corrosion or damage
Reinstall the option board on turn power on.

Link to Analog Inputs page does not appear

The controller not detecting an analog input board at power up causes this problem.

Possible Causes

No analog input board is installed

Poor connection of the option board

Corrective Actions

Install the analog input option board and turn power on.

Remove the option board and inspect both mating connectors for corrosion or damage
Reinstall the option board on turn power on.

Link to Software Upgrade page does not appear

This is a normal situation if your WebMasterONE has the latest revision of software installed. When a new version of software becomes available, the link will appear, you will be able to see a description of the changes, and will have the option to download it if you want.

8.3 CONNECTION PROBLEMS

“The page cannot be displayed” message on your browser

This is a standard Microsoft Internet Explorer message when a web page cannot be located.

Possible Causes

Connection has timed out.

Corrective Actions

Reconnect to WebMasterONE.

Invalid Session message instead of a page loading

Possible Causes

Session has timed out.

You’ve left the WebMasterONE pages to other Web sites and have been gone longer than 2 minutes.

Corrective Actions

Click the “log in” link, and log in again.
Increase session timeout in the Access Code page if desired.

Click the “log in” link, and log in again.

Pages load slowly

The time required for pages to load depend upon the amount of information contained in the page, the processing speed of your computer, the amount of RAM available in your computer, and the method of connecting (Ethernet, Internet, or USB connection). We recommend a minimum processor speed of 100 MHz, and minimum RAM of 40 MB.

If connecting over the Internet, then your modem speed and the amount of Internet traffic come into play as well. The WebMasterONE modem is 33K baud, so if your PC's modem is 33K baud or higher, the numbers below should be valid, given light Internet traffic.

In general, this is what you should expect:

<u>Type of Page</u>	<u>Connection Method</u>	<u>Time to Load</u>
First page loading after log in	Ethernet	30-90 seconds
System Summary, 4-20 Input, Start Up, Datalog, Comms	Ethernet	7-25 seconds
Other pages	Ethernet	3-10 seconds
First page loading after log in	USB	30-90 seconds
System Summary, 4-20 Input, Start Up, Datalog, Comms	USB	22-35 seconds
Other pages	USB	7-14 seconds
First page loading after log in	Internet	30-90 seconds
System Summary, 4-20 Input, Start Up, Datalog, Comms	Internet	13-20 seconds
Other pages	Internet	4-8 seconds

9.0 SERVICE POLICY



The WebMasterONE Series Controllers have a 2-year warranty on electronic components and a 1-year warranty on mechanical parts (keypad, terminal strip and relays). Conductivity sensors and pH/ORP electrodes have a 1-year warranty *against manufacturing defects only*.

We stock replacement parts for immediate exchange after we have isolated the cause of a problem.

Factory authorized repairs that are received via next-day-air will be returned within 24 hours. Normal turnaround time for returns is two weeks.

Out of warranty repairs are done on a flat fee basis.